

**WECCO**

# SMART SERIES

ALL IN ONE



Single-phase version

Copyright © Weco S.r.l. 2024. All rights reserved.

### Legal Notice

No part of this document may be reproduced, distributed or transmitted in any form or by any means without the prior written consent of WeCo S.r.l.

### Disclaimer

The contract stipulated between WeCo S.r.l. and the customer regulates the purchase and use of the agreed products, services and features. Some or all of the items described in this document may not be within the scope of the customer's purchase or use. Unless otherwise specified in the agreement, all representations, information and recommendations contained in this document are provided "AS IS", without warranty of any kind, either express or implied.

The information contained in this document is subject to change without notice. Although every effort has been made to ensure the accuracy of the contents, WeCo S.r.l. does not provide any warranty, explicit or implicit, as to their completeness, reliability or suitability for a particular purpose.

WeCo S.r.l. always recommends consulting an experienced technician or professional before purchasing, requesting the most recent version of the manual and technical data sheets from WeCo. Purchase and installation should only be made after careful evaluation of the product, its warranties, and technical documentation.

Although WeCo batteries and inverters do not require constant maintenance, they still need to be monitored and checked on a weekly basis. This allows you to prevent any alarms or malfunctions which, if neglected, could cause greater damage. In addition, batteries and inverters should be inspected regularly, ensuring that the dissipation areas are clean, that the system is functioning properly, and that the installation, connections, and water tightness are adequate.

In the event of an alarm or error that does not self-reset within 24 hours, no manual restart should be attempted. In these cases, the system should be shut down immediately and a specialist technician should be contacted for diagnosis and intervention. Restarting manually is not a solution – it may temporarily clear the error memory without fixing the underlying problem, potentially making the situation worse and increasing the risk of future damage.

No part of this document may be reproduced or transmitted in any form or by any means without the prior written consent of Weco S.r.l.

# About this document

## Preliminary notes

## Declaration

The information and indications contained in this manual refer to the WECO stackable battery model 5K0 PRO combined with the SMART SINGLE-PHASE series inverter:

In the event of product updates or other reasons, this document will be adjusted accordingly without prior notice or publicity, it will be made available on the WECO website in the download section.

Unless otherwise agreed, this document is to be used as a guide only and never supersedes the Laws of your State.

All statements, information and advice in the documentation do not constitute any express or implied action that contradicts local regulations or standards.

For further information or clarification, please contact us before installing the product.

Official information and the latest data sheet can be found on [www.wecobatteries.com](http://www.wecobatteries.com).

It is essential that the battery module is equipped with the latest firmware version available. New batteries are always shipped with the latest firmware version available at the time.

From time to time, the firmware will be updated to improve the functionality and performance of the battery and/or inverter.

Firmware is always available on the [www.wecobatteries.com/download-area](http://www.wecobatteries.com/download-area).

The latest firmware version is always available for free and can be updated by your local installer. You can always contact [service@wecobatteries.com](mailto:service@wecobatteries.com) for more information on the upgrade process.

Keep your system connected to the internet to benefit from firmware update notifications issued by WeCo.



### ATTENTION

The release of "**critical updates**" implies the mandatory installation of the FW within 60 days in order not to lose the right to the warranty, see Limited Warranty conditions.

The update can be done directly from a phone with a Bluetooth APP, staying in the immediate vicinity of the system without the need to create an account via the NOOR APP and even in the absence of a cellular network and/or local Wi-Fi network.

**Preface:**

Thank you for choosing our product.

We will provide you with a high-quality product and reliable after-sales service.

To avoid injury to personnel and damage to the product, please read this manual carefully.

This manual provides detailed information on the operation, maintenance, and troubleshooting of the product, as well as health and safety recommendations.

Some users may not find all the information in this manual sufficient or unclear, therefore, before installing or purchasing WeCo products, they may request a dedicated training course in person or via remote connection.

**Declaration:**

The manufacturer reserves the right of final explanation of any contents of this manual.

These batteries cannot be used to power life-saving devices or for UPS or Back-up use to power or support life-saving medical devices.

Capacity is not constant with each cycle and can vary based on many factors, energy degradation is not constant over time or cycles, and is strongly influenced by temperature, C-Rate, and DoD (Depth of Discharge).

The first 500 cycles are typically affected by a greater decrease in capacity than subsequent cycles.

Before purchasing this product please read the warranty terms available on our website.

Always check the latest technical data on our website as it may be changed.

If this manual is not clear to you, do not purchase or install the battery, please ask for a technical meeting by writing to [service@wecobatteries.com](mailto:service@wecobatteries.com).

Limited Performance Warranty Documents set parameters to get the best performance out of the battery based on the standard test condition used by WeCo.

Any additional details about this battery, its BMS, inverters and their management can be requested by writing to [service@wecobatteries.com](mailto:service@wecobatteries.com).

This battery and its accessories are intended to be installed, maintained, and supervised only by experienced and qualified installers.

All trademarks in this manual belong to their legitimate owners; Third party trademarks, product names, trade names, company names and companies mentioned may be trademarks owned by their respective owners or registered trademarks of other companies and are used for explanatory purposes only and for the benefit of the owner, without any purpose of infringing applicable copyright.

The evaluation of the product is an important and necessary phase and must precede the purchase, it is advisable to evaluate the latest technical data sheets made available on the [www.wecobatteries.com](http://www.wecobatteries.com) website or request a copy directly from [sales@wecobatteries.com](mailto:sales@wecobatteries.com).

Our products and manuals are mainly dedicated to installers and technicians who are experts in the sector with specific qualifications for electrical systems.

The manual, the system certification and the "first start-up" test certificate of the entire system performed according to the national standards of your country, must be given to the end user after adequate training on the use and maintenance of the lithium battery, inverter and connected accessories, in general of the system in its entirety.

These products are intended to be integrated into more complex systems installed only by professional operators.

After reading the manual in full, we hope you can buy our products, before doing so always ask for the most up-to-date version of the manual and technical data of the product you intend to buy.

The pre-purchase evaluation is an important phase and for this reason it must be conducted carefully and perhaps with the help of qualified and experienced technicians if your knowledge on the subject is not sufficient.

## NOTES ON TEMPERATURES

Pay attention to the distinction between BMS temperatures and the operating temperatures of the battery as a lithium accumulator, i.e. the temperatures to which the BMS can be exposed without being damaged, malfunctioning or being affected in the reading of data such as temperatures voltage current (an incorrect reading of the data for exposure to out-of-range temperatures could affect the control and safety logic). The lithium battery should not be exposed to temperatures that are too low or too high, while the temperature excursions of the environment in which they will be installed should remain as constant as possible. Below you will find correct instructions on the use of the battery and the permissible and recommended temperatures.

The technical data sheets may be subject to change due to market or industrial needs, therefore, the technical data sheets present on third-party websites or in any case distributed in the past may not be updated and in any case correct. Get the latest official releases from [service@wecobatteries.com](mailto:service@wecobatteries.com).

WeCo batteries are developed for domestic and industrial applications and can only be installed and maintained by experienced and qualified personnel, they are not produced for direct sale to private individuals.

ESS (Energy Storage Systems) batteries for domestic applications are designed to maximize the self-consumption of energy from renewable sources. Use for backup systems, or for UPS systems, is possible within the charge/discharge current limits of the ESS.

This manual provides detailed information on the operation, maintenance, and troubleshooting of the product, as well as health and safety advice; The information in this manual may not be sufficient to cover specific applications, so if your specific case is not mentioned, please do not purchase our batteries until every technical and safety aspect of your specific application has been clarified. You can request technical support from [service@wecobatteries.com](mailto:service@wecobatteries.com).

WeCo offers two types of warranty on its products, the warranty on manufacturing defects also known as the European warranty and in addition the warranty on performance, this subject to compliance with installation requirements well defined in the warranty document. More information can be found in this manual and on the specific warranty document available for each battery model.

## SYSTEM DESIGN BY EXPERIENCED TECHNICIANS

Systems Design is the process of defining the architecture, components, modules, interfaces, and load data for a system by the customer in order to meet the specified requirements

For a solar system these components are the PV modules, the inverter/charge controller and the batteries, as well as the different interfaces of these components.

These systems must be integrated with each other following the respective technical rules and must be compatible with each other. The design must take into account functional guarantees and performance guarantees in order to guarantee the end customer full satisfaction of the product he will use.

For safety reasons, if the battery is not operating at the temperatures, currents and DODs specified in the performance warranty requirements, it should be inspected frequently according to the conditions of use applied.

WeCo bases warranty and safety on the standard conditions of use described above; Heavier uses and at suboptimal temperatures will have direct effects on premature battery aging and intrinsic safety.

With System Design, the designer, based on the prescriptions of this manual and on his own experience, must guarantee some important steps:

**System longevity:** Establishing an appropriate frequency for maintenance and inspections can extend the useful life of the system, preventing premature failures and ensuring that the system operates at optimal levels for as long as possible.

**Safety:** Regular maintenance and inspections help identify and fix potential safety issues before they can cause accidents or malfunctions.

**Operational efficiency:** A well-maintained system tends to operate more efficiently, with fewer interruptions due to failures or malfunctions, thus ensuring better performance and reliability.

Although maintenance is limited to regular checks, it is considered necessary to carry out a maintenance contract and annual verification of wiring and connections as well as a weekly inspection, cleaning and functionality check both by the APP and in person to ensure the correct general functioning of the system

**Cost Consideration:** Although regular maintenance incurs additional costs, it actually helps to reduce overall costs in the long run, preventing costly failures and extending the life of the system as well as being necessary to ensure the safety of electrical systems, always refer to local regulations regarding scheduled maintenance electrical checks and mechanical checks of the installed system. To ensure that these maintenance practices are followed correctly, it is essential that they are well documented and passed on to the end customer or maintenance person. This includes the preparation of a detailed maintenance plan, which specifies the frequency of different maintenance and inspection activities, based on the specific characteristics of the site and the application in which the system is installed.

## **BATTERY OPERATION**

There are several factors that affect the operation of the battery in terms of its ability to provide capacity and life expectancy. If you respect the battery, it will work safely and efficiently for many years.

### **Storage**

#### Temperature of Use and Thresholds

Many chemical reactions are affected by temperature and this is also true for the reaction that occurs in a WeCo storage battery. The chemical reaction of a lithium ion is slowed down by the lowering of the temperature of the electrolyte contained in the battery, which translates into a lower capacity and a higher long-term performance decay index in direct proportion to the departure from the optimal temperature prescribed by WeCo.

A new battery that provides 100% of the rated capacity at 25°C will only provide about 75% of the rated capacity when used below 10°C.

Charging by the BMS is not normally allowed at 0°C, except for the emergency condition managed by the BMS, if the heating system is inhibited because the state of charge of the battery is below the minimum level for its start-up, the battery cannot be charged if the temperature detected by the BMS is below the minimum allowed threshold.

At temperatures below -5°C the BMS will only allow 0.03C of charging current for emergency charges; at temperatures below -10°C, charging is prohibited.

Although it is possible to discharge the battery down to -20°C, it will then be impossible to recharge it at this temperature as the charging phase is prohibited below 0°C, obviously the appropriate ambient temperatures must be restored for the charging phase. These thresholds do not mean that the battery warranty applies even under such conditions, even if allowed by the BMS as extreme values. Temperatures negatively affect performance, the optimal range of cell temperatures should remain between +20°C +/- 10°C to achieve optimal performance

The logics allowed by the BMS do not coincide with the thresholds to be respected in order to benefit from the performance warranty, as compliance or non-compliance with the latter is up to the end customer, while the limitations inherent in the battery safety thresholds are set by the BMS as factory data.

The customer can request from WeCo the maximum and minimum limit of temperature and charging and discharging current to remain within the temperature ranges required for the performance warranty, the placement of the battery in an environment not equipped with a controlled temperature could expose the battery to temperatures outside those allowed for the warranty

The warranty conditions (Functional and Performance) are well described in the "Limited Warranty" document and should be read before purchasing the product.

For the performance warranty, WeCo requires that the batteries and inverters be installed as per the instructions in the manual and, although in IP65 or IP66 class like the batteries, these must be protected from bad weather, direct light and agents that can damage their characteristics

For the warranty against factory defects, higher temperatures are allowed, i.e.  $-5^{\circ}\text{C}$   $+40^{\circ}\text{C}$ , ventilated room and/or area repaired and intended for the installation of batteries and electrical systems. They must be free from condensation and must protect the system from rain, sun, poles and acidic agents.

For warranty purposes batteries must not result in Under Voltage alarms; therefore, in the absence of grid or solar power the inverter may not charge the batteries when needed and they could be damaged. For this reason, a weekly check of the batteries is necessary. Most battery capacity/life issues can be traced back to improper charging. Incorrect charging settings can lead to an overcharging or undercharging condition, any incorrect charging process will affect the battery life or its ability to retain power.

The lower the C-Rate of the charge/discharge process, the more the battery will benefit from long-term performance.

Depth of Discharge (DoD %)

The depth of discharge is a function that is implemented through the setting of the hybrid inverter, compatible with WeCo.

The deeper the discharge, (e.g. DoD 100% means completely discharging the battery), the shorter the battery life over its estimated useful life.

The number of cycles and the DoD specification will affect the expected life in years that the battery/battery system will provide prior to replacement.

To maximize the remaining capacity over the battery's useful life period, it is recommended to set the inverter's DoD to 20%, this will help the maintenance of health (SoH) for longer.

For safety reasons, if the battery is not operating at the temperatures, currents and DODs specified in the performance warranty requirements, it should be inspected frequently according to the conditions of use applied.

WeCo bases the warranty and safety on the standard conditions of use described above, heavier uses and at suboptimal temperatures will have direct effects on the premature aging of the battery and with it the intrinsic safety, even if it is equipped with a heating system it is always recommended to keep the battery in a temperate environment.

### **Charge/Discharge**

Most battery capacity/life issues can be traced back to improper charging also due to improper location. Improper charging settings can lead to an overcharge or over-discharge condition or out-of-range current for the temperature condition and SOC%.

WeCo only guarantees batteries connected via CAN BMS line to the compatible inverter or to its own inverters, whether they are SMART, H-ESY or TK series (see compatibility list on the [www.wecobatteries.com](http://www.wecobatteries.com) website) and used according to the warranty prescriptions published on the website.

CAN/BMS communication is essential both for active and passive safety reasons and in order to be able to conduct all active control interactions with the inverter. The BMS has dynamic algorithms that vary according to current or previous conditions stored during the charge-discharge or stand-by phases.

Modern inverters / charge controllers are equipped with a CAN / BMS interface and no special settings are required to charge and discharge the battery, except for the setting of the charge / discharge power and the DoD% (if the customer wants to comply with the STC requirements, he must read and comply with the warranty conditions defined as STC and set them on the inverter).

Maintenance at optimal temperature, on the other hand, must be guaranteed by the technical room and the air conditioning equipment installed in it, the inverter is not able to interact with the settings with reference to the temperature of the environment in which it is installed, also because the inverter and battery could be exposed to different environmental factors in different environments.

### **Firmware Updates**

In the event of BMS and/or inverter firmware updates as a result of improvements, corrections, or other reasons, this manual and warranties may be updated accordingly. Check the release notes for critical firmware on the site [www.wecobatteries.com](http://www.wecobatteries.com) at your distributors. Critical Release Firmware must be installed as per warranty requirements: To obtain support if your system is not equipped with a WiFi module, please contact [service@wecobatteries.com](mailto:service@wecobatteries.com).

All WeCo batteries can be equipped with a WiFi system for connection to the WeCo Cloud, this solution ensures that they are always updated to the latest FW version notified in the APP, the Upgrade function must still be piloted by the user as during the update the battery will have to turn off for safety reasons and it is therefore necessary to plan this action in such a way that no inconvenience is created for the users of the system.

The FW update can also be carried out locally via Bluetooth App, even in the absence of WiFi; you must have a 4G connection and keep the Bluetooth App open until the App displays: "NEW FIRMWARE AVAILABLE" after which you can reach the battery in an area not covered by data signal and/or Wi-Fi and perform the FW update via the BT connection.

### **Legal Information**

Unless otherwise agreed, this document is intended to be used only as a guide to the installation, maintenance and management of the product, all statements, information and advice contained in the documentation do not constitute any express action or implied statement in contradiction with local regulations or standards.

For more information, please contact us.

Official information and the latest data sheet are available on [www.wecobatteries.com](http://www.wecobatteries.com); however, they can be requested in real time at [service@wecobatteires.com](mailto:service@wecobatteires.com). Hyperlinks, third-party links, digital datasheets published on web social media or even printed in print media may not be updated to the current version of the product. Before purchasing the product, check the website for technical data and warranties updated to the current date.

It is essential that the battery unit is equipped with the latest firmware version available on the [www.wecobatteries.com](http://www.wecobatteries.com) site or WeCo APPs.

From time to time, WeCo will release a new firmware to improve the functionality of the battery, if your battery is equipped with WiFi (Paid Accessory) and you are registered on our APP, the new firmware will be visible in the APP and can be updated with a simple click from your phone.

The latest firmware version is always available for free; the battery firmware can be updated by the local installer via RS232/USB and Windows PC (reserved for installation technicians) or via APP for batteries equipped with WiFi dongles.

You can also write an email to [service@wecobatteries.com](mailto:service@wecobatteries.com) to understand and be supported in the upgrade process.

### **Production guarantee**

The two-year legal warranty covers the product against manufacturing defects found on delivery or arising within two years, provided it is installed and used in accordance with the requirements of this manual. Although the battery BMS allows for a wide range of use, both in terms of temperature and charging currents, and DOD this should not be interpreted as an implied authorization to use the battery at these levels.

For purposes of the Performance Warranty, it is mandatory that the battery be used in the range of temperature and charge/discharge current and depth of discharge indicated in the Performance Warranty.

See the Limited Warranty Document.

### **Performance guarantees**

This is an additional warranty and applies only to batteries connected via BMS line to an approved inverter, the battery operating parameter must remain within the performance warranty terms.

Any other use, even if permitted by BMS ranges, is not covered by the Performance Warranty.

See the limited warranty document available on the [www.wecobatteries.com](http://www.wecobatteries.com) website.

### **General information about batteries and LFP chemistry**

Knowing a lithium battery is important for good and optimal storage. An informational guide is available on the website [www.wecobatteries.com](http://www.wecobatteries.com) the Guides and Technical Information section.

## Purpose





This document introduces the main features, component composition, installation and use, maintenance and maintenance of the hybrid bidirectional inverter The All-in-One Solar Storage System (hereinafter referred to as 5K0 Smart).

## Recipients

- This document is intended to:
- System Installation Engineers
- Technical Support Engineers
- Product Maintenance Engineers
- End users

## Symbol conventions

The symbols that can be found in this document are defined as follows.

Symbol	Description
 <b>DANGER</b>	Indicates a hazard with a high level of risk that, if not avoided, will result in death or serious injury.
 <b>ATTENTION</b>	Indicates a hazard with a medium level of risk that, if not avoided, could result in death or serious injury.
 <b>ATTENTION</b>	Indicates a hazard with a low level of risk that, if not avoided, could result in minor or moderate injury.
 <b>NOTICE</b>	Indicates device or environmental safety warning information that, if not avoided, could result in equipment damage, data loss, performance degradation, or unexpected results.  NOTICE is used to address practices not related to personal injury.
 <b>NOTE</b>	It complements the critical information contained in the main text.  NOTE is used to indicate information unrelated to personal injury, equipment damage, and environmental deterioration.

# Contents

<b>About this document .....</b>	<b>ii</b>
<b>Contents .....</b>	<b>ix</b>
<b>1 Safety Information .....</b>	<b>1</b>
1.1 Personal Safety.....	2
1.2 Electrical Safety.....	3
1.3 Environmental requirements .....	5
1.4 Mechanical Safety.....	6
1.5 Battery Safety.....	8
<b>2 Guide .....</b>	<b>11</b>
<b>3 Product Introduction .....</b>	<b>12</b>
3.1 Overview.....	12
3.2 Model.....	12
3.3 Appearance .....	12
3.4 Nameplate .....	14
3.5 Technical Specifications.....	14
<b>4 Component Introduction.....</b>	<b>15</b>
4.1 Inverter Module .....	15
4.1.1 Appearance .....	15
4.1.2 Control Panel.....	15
4.2 Battery Extension Module.....	17
4.3 Battery Base .....	18
<b>5 System Installation .....</b>	<b>19</b>
5.1 Preparing for Installation .....	19
5.1.1 Accepting Unpacking.....	19
5.1.2 Packing slip.....	19
5.2 Installation Environment, Space, and Safety Requirements.....	21
5.2.1 Installation Environment Requirements.....	21
5.2.2 Space Requirements for Installation .....	22
5.2.3 Safety installation Requirements .....	22
5.3 Installation Steps.....	23
5.3.1 Step 1. Install the base. ....	23
5.3.2 Step 2. Stack the first battery module on the base .....	24
5.3.3 Step 3. Stack the second one and rest the battery module. ....	27
5.3.4 Step 4. Install the inverter module.....	30
5.4 Electrical Connection .....	33
5.4.1 System Connection Diagram .....	33
5.4.2 Installing the DC Input Power Cables .....	33
5.4.3 Installing the mains/load connection cable .....	34
5.4.4 Communication Connection .....	35
5.4.5 Installing a PE cable.....	37
5.5 Installing the Cover .....	42

---

<b>6 System Commissioning</b> .....	<b>43</b>
6.1 Starting the All-In-One .....	43
6.2 Shutting Down the System.....	44
<b>7 Human-Computer Interaction</b> .....	Errore. Il segnalibro non è definito.
7.1 System Interface .....	46
7.1.1 Standby Interface .....	47
7.1.2 Operation Information Menu.....	48
7.2 System Setup.....	49
7.2.1 Download dell'app .....	49
7.2.2 Connecting the WiFi Module .....	50
7.2.3 Data Visualization.....	53
7.2.4 Parameter Settings.....	53
7.3 Working Mode .....	54
7.3.1 Auto Mode .....	54
7.3.2 Peak Shaving .....	55
7.3.3 Battery Priority.....	56
<b>8 Maintenance</b> .....	<b>58</b>
8.1 Route Maintenance.....	58
8.2 Troubleshooting .....	58
8.3 Out-of-Service Disposal.....	60
8.4 Quality Assurance .....	61

# 1 Safety Information

## WARNING: Safety

**Before transporting, storing, installing, operating, operating, and maintaining the equipment, please read this document, strictly follow the instructions provided herein, and follow all safety instructions on the equipment and in this document.**

In this document, the term "equipment" refers to the products, software, components, spare parts, and services related hereto; "the Company" refers to the manufacturer (manufacturer), seller and service provider of the equipment; "You" refers to the entity that transports, stores, installs, manages, uses, and maintains the Equipment.

The **hazard, warning, caution** and **notice** statements described in this document do not cover all safety precautions. You must also comply with relevant international, national, or regional standards and industry practices. **The Company shall not be liable for any consequences arising from violations of safety requirements or standards relating to the design, manufacture and use of the equipment.**

The equipment must be used in an environment that meets the design specifications. Failure to do so may result in the equipment being defective, malfunctioning, or damaged and not covered by the warranty. The Company shall not be liable for any loss of property, personal injury, or even death caused by this.

Comply with applicable laws, regulations, standards, and specifications during transportation, storage, installation, operation, use, and maintenance.

Do not reverse engineer, decompile, disassemble, adapt, plant, or other derivative operations on the equipment software.

Do not study the internal implementation logic of the equipment, obtain the source code of the equipment software, infringe intellectual property rights, or disclose the performance test results of the equipment software.

**The Company shall not be liable for any of the following circumstances or their consequences:**

- The equipment is damaged due to force majeure such as earthquakes, floods, volcanic eruptions, debris flows, lightning, fires, wars, armed conflicts, typhoons, hurricanes, tornadoes, and other extreme weather conditions.
- The equipment operates beyond the conditions specified herein.
- The equipment is installed or operated in environments that do not comply with international, national, or regional standards.
- The equipment is installed or operated by unqualified personnel.
- The operating instructions and safety precautions stated on the product and in the document are not observed.
- You remove or modify the product or software code without authorization.
- You or a third party authorized by you may cause damage to the equipment during transportation.
- The equipment is damaged due to storage conditions that do not meet the requirements specified in the product document.
- Materials and tools that comply with local laws, regulations, and standards are not prepared.
- The equipment is damaged due to negligence, intentional breach, gross negligence, improper operation, or other reasons unrelated to the Company by you or any third party.

## 1.1 Personal safety



- Ensure that the power supply to each source is turned off and/or isolated during installation. Do not install or remove a cord with the power on. Transient contact between the cable core and the conductor or frame will cause arcing, sparks, loose or explosion, which may cause personal injury, even indirect, due to damage caused to batteries and other objects forming part of the system or installation.
- Non-standard and/or improper operations on live equipment may cause fire, electric shock, or explosion, resulting in property damage, personal injury, or even death.
- Before operations, remove conductive objects such as watches, bracelets, bracelets, rings, and necklaces to avoid electric shock.
- During operations, use dedicated insulated tools to prevent electric shock or short circuits. The dielectric strength voltage level must comply with local laws, regulations, standards, and specifications.
- During operations, wear personal protective equipment such as protective clothing, insulated shoes, goggles, safety helmets, and gloves.

### General requirements

- Do not remove protective equipment. Heed the warnings, cautions, and related preventive measures contained in this document and on the equipment.
- If there is a likelihood of personal injury or equipment damage during operations, stop immediately, report the case to the supervisor, and take actionable protective measures.
- Do not turn on the equipment before it has been installed or confirmed by professionals.
- Do not touch the power equipment directly or with conductors such as damp objects. Before touching any surface of the conductor or terminal, measure the voltage at the point of contact to ensure that there is no risk of electric shock.
- Do not touch the operating equipment because the casing is hot.
- In the event of a fire in the building or parts of the system even if not caused by the batteries or inverters themselves, leave the building or equipment area immediately and trigger the alarm if present or call emergency services. Do not enter the building or area of the affected equipment under any circumstances.
- If the fire can be extinguished with the suppression tools present in the building and if you are trained in fire protection/prevention/suppression, do your best to extinguish the fire

### Staff requirements

- Only professionals and trained personnel are allowed to operate the equipment.
- Professionals: Personnel who are familiar with the principles of operation and structure of the equipment, trained or experienced in the operation of the equipment, and who are clear of the sources and degree of various potential hazards in the installation, operation, and maintenance of the equipment
- Personnel trained according to the Laws of the Country: personnel trained in technology and safety, with required experience, aware of the possible dangers to themselves in certain operations and able to take protective measures to minimize the dangers to themselves and other people.
- Personnel planning to install or maintain the equipment must receive appropriate training, perform all operations correctly, and understand all necessary safety precautions and relevant local standards.
- Only qualified professionals or trained personnel are allowed to install, operate, and maintain the equipment.
- Only qualified professionals can remove safety structures and inspect the equipment.
- Personnel performing particular tasks, such as electrical operations, work at height, and operations with special equipment, must possess the required local qualifications.

- Only authorized professionals may replace the equipment or components (including software).
- Only personnel who are required to work on the equipment are allowed to access the equipment.

## 1.2 Electrical safety



### DANGER

- 
- Before connecting the cables, make sure that the equipment is intact. Failure to do so may result in electric shock, **DO NOT OPERATE ON EQUIPMENT THAT IS DAMAGED or HAS SUFFERED SHOCK/IMPACT**
  - Non-standard and improper operation may result in electric or loose shock.
  - Do not allow foreign objects to enter the equipment during operations. Failure to do so may result in equipment damage, load power derating, failure, or personal injury.
- 



### ATTENTION

---

The equipment that needs to be grounded, install the grounding wire first when installing the equipment, and remove the grounding wire last when removing the equipment.

---

### General requirements

- Follow the procedures outlined in the document for installation, operation, and maintenance. Do not rebuild or modify the equipment, add components, or change the installation sequence without authorization.
- Obtain approval from your national or local electric utility company before connecting equipment to the grid.
- Comply with the safety regulations of the country regulations
- Install temporary fencing or warning ropes and hang "No Entry" signs around the operating area to keep unauthorized personnel away from the area.
- Before installing or removing power cords, turn off the equipment breakers and their upstream and downstream switches.
- If liquid is detected inside the equipment, disconnect the power immediately and do not use the equipment.
- Before performing operations on the equipment, verify that all tools meet the requirements and record the tools. After completing the operations, gather all the tools to prevent them from remaining inside the equipment.
- Before installing power cords, verify that the wire labels are correct and that the wire terminals are insulated.
- When installing the equipment, use a torque tool with a suitable measurement range to tighten the screws. When using a wrench to tighten screws, make sure that the wrench does not tilt and that the torque error does not exceed 10% of the specified value.
- Make sure the bolts are tightened with a torque tool and marked red and blue after a double check. Installation personnel mark tightened bolts in blue. Quality inspection personnel confirm that the bolts are tightened and then mark them in red. (The markings must go through the edges of the bolts.)
- After installation, make sure that the protective enclosures, insulating tubes, and other items required for all electrical components are in place to prevent electric shock.
- If the equipment has multiple inputs, disconnect all inputs before using the equipment.
- Before servicing an electrical or downstream power distribution device, turn off the output switch on the power equipment.
- When servicing the equipment, apply "Do Not Turn On" labels near the upstream and downstream switches or circuit breakers and warning signs to prevent accidental connections. The equipment can only be turned on after troubleshooting has been completed.
- If fault diagnosis and troubleshooting are required after power, take the following safety measures: Disconnect the power supply. Check if the equipment is live. Install a ground wire. Hang warning signs and install fences.

- Do not open the equipment panels. Periodically check the equipment connections on a weekly basis for the first 6 months and then every 6 months, making sure that all screws are securely tightened and that the cables are securely connected and tight
- Only qualified professionals can replace a cable or part of the system
- Do not damage or scratch the labels or nameplates on the equipment. An illegible label results in the loss of the warranty
- Do not use solvents such as water, alcohol, or oil to clean electrical components inside or outside the equipment.

## Grounding

- Make sure that the grounding impedance of the equipment complies with local electrical standards.
- Make sure the equipment is permanently connected to the protective ground. Before using the equipment, check its electrical connection to ensure that it is reliably grounded.
- Ground testing must be carried out before and after the system is connected and before testing.
- The grounding check and issuance of the certificate must be carried out after the system has been started up with the inverter and batteries on and with the inverter and batteries switched off
- Do not touch and/or work on the equipment without a properly installed ground conductor.
- Do not damage or disconnect the ground conductor.
- For equipment using a three-pin receptacle, make sure the ground terminal in the receptacle is connected to the protective grounding point.
- If high contact current may occur on the equipment, ground the protective grounding terminal on the enclosure before connecting power; Otherwise, an electric shock may occur due to the contact current and damage the inverter and batteries

## Wiring requirements

- When selecting, installing, and routing cables, follow local safety regulations and rules.
- When routing power cords, make sure they do not twist or kink. Do not splice or solder power cords. If necessary, use a longer cable.
- Make sure all cables are properly connected and insulated, and meet specifications.
- Make sure that cable routing slots and holes are free of sharp edges, and that locations where cables are routed through pipes or cable holes are equipped with cushioning materials to prevent wires from being damaged by sharp edges or burrs.
- Make sure that cables of the same type are tied together neatly and straight, and that the cable sheath is intact. When routing cables of different types, make sure they are far away from each other without getting tangled and overlapping.
- When the cable connection is completed or paused for a short time, immediately seal the cable holes with sealing putty to prevent small animals or moisture from entering.
- Secure underground cables using cable holders and cable clips. Make sure that the wires in the filling area are in close contact with the ground to prevent deformation or damage to the cables during filling.
- If external conditions (such as cable layout or ambient temperature) change, check for cable usage according to IEC-60364-5-52 or local laws and regulations. For example, verify that the current load capacity meets the requirements.
- When routing cables, reserve a gap of at least 30 mm between wires and heat-generating components or areas. This prevents deterioration or damage to the cable's insulating layer.
- When the temperature is low, violent shocks or vibrations can damage the plastic cable sheath. To ensure safety, please comply with the following requirements:
- Cables may only be laid or installed when the temperature is above 0°C. Handle cables with caution, especially at low temperatures.
- Cables below 0°C should be stored at room temperature for more than 24 hours before being laid down.
- Do not perform improper operations, such as dropping cables directly from a vehicle. Otherwise, the cable's performance may deteriorate due to damage to the cable, which affects the current-carrying capacity and temperature rise.

## Environmental requirements



### DANGER

- Do not expose the equipment to flammable or explosive gases or smoke. Do not perform any operation on the equipment in such environments.
- Do not store flammable or explosive materials in the area of the equipment.
- Do not place the equipment near heat or fire sources, such as smoke, candles, stoves, or other heating devices. Overheating may damage the equipment or cause a fire.
- Do not install in areas where flammable materials, gases or combustibles are or may be present



### ATTENTION

- Install the equipment in an area away from liquids or possible flooding.
- Do not install in areas prone to condensation or near water pipes and exhaust air vents, or areas prone to water leakage, such as air conditioner vents, vents, or machine room supply windows. Make sure that no liquid enters the equipment to prevent failure or short circuit.
- To avoid damage or fire due to high temperature, make sure that air vents or heat dissipation systems are not blocked or covered by other objects while the equipment is operating.

## General requirements

- The installation and use environment must meet relevant international, national, and local standards for lithium batteries, and must comply with local laws and regulations. The user is responsible for protecting the ESS from fire or other hazards.
- Keep the ESS out of the reach of children and away from daily work or living areas, including but not limited to the following areas: study, bedroom, living room, living room, music room, kitchen, study, game room, home theater, porch, toilet, bathroom, laundry room, and attic.
- When installing the ESS in a garage, keep it away from the unit's path. It is recommended to mount the ESS on the topmost wall of the bumper to avoid collisions.
- Do not install the ESS in indoors, unventilated locations that lack proper combat facilities or are difficult for firefighters to access. Do not place flammable or explosive materials around the ESS. It is recommended to mount the ESS on a wall to prevent contact with water.
- Install the ESS in a sheltered place or install an awning to avoid direct sunlight or rain.
- For areas prone to natural disasters such as floods, debris flows, earthquakes, and typhoons, please take the corresponding precautions for installation.
- Do not install the ESS in an easily accessible location because the temperature of the enclosure and heat sink is high when the ESS is operating.
- Do not install the ESS on a moving object, such as a ship, train, or car.
- Ensure that the equipment is stored in a clean, dry, and well-ventilated area with adequate temperature and humidity, and protected from dust and condensation.
- Keep the installation and operating environments of the equipment within the permissible ranges. Otherwise, its performance and safety will be compromised.
- Do not install, operate, or operate outdoor equipment and cables (including but not limited to moving equipment, operating equipment and cables, inserting or removing connectors from signal ports connected to outdoor structures, working at height, installing outdoors, and opening doors) in severe weather conditions such as lightning, rain, snow, and level 6 or stronger wind.
- Do not install the equipment in an environment with direct sunlight, dust, smoke, volatile or corrosive gases, infrared and other radiation, organic solvents, or salty air.

- Do not install the equipment in an environment with conductive metal or magnetic dust.
- Do not install the equipment in an area that promotes the growth of microorganisms such as fungi or mold.
- Do not install the equipment in an area with solid vibration, noise, or electromagnetic interference.
- Make sure that the site complies with local laws, regulations, and standards.
- Ensure that the soil in the installation environment is solid, free of spongy or soft soil, and not prone to sagging. The site must not be located on flat ground subject to water or snow accumulation, and the horizontal level of the site must be higher than the highest water level in the history of that area.
- Do not install the equipment in a location that may be submerged in water.
- If the equipment is installed in a location with abundant vegetation, in addition to routine weeding, harden the soil underneath the equipment using concrete or gravel.
- Do not install the equipment outdoors in areas affected by salt because it may be damaged. An area affected by salt is located less than 500 m from the coast or subject to sea breezes. Regions subject to sea breezes vary according to weather conditions (such as typhoons and monsoons) or terrain (such as dams and hills).
- Before installation, operation, and maintenance, clean water, ice, snow, or other foreign objects on the top of the equipment.
- When installing the equipment, make sure that the installation surface is solid enough to withstand the weight of the equipment.
- After installing the equipment, remove packaging materials such as cartons, foam, plastic, and cable ties from the equipment area.
- Store the equipment according to storage needs. Damage to equipment caused by unqualified storage conditions is not covered by the warranty.
- The operating temperature range provided in the technical specifications of the equipment refers to the ambient temperature in the installation environment.
- 

## Mechanical safety



- 
- Make sure that a professional organization prepares and inspects all the necessary tools. Do not use tools with scratch marks, do not exceed the inspection or whose inspection validity period has expired. Make sure the tools are secure and not overloaded.
  - Do not drill holes in the equipment. This could affect the holding performance of the equipment, electromagnetic containment, and damaged components or cables inside. Metal chips from drilling can short-circuit the boards inside the equipment.
- 

### ○ General requirements

- Promptly repaint any paint scratches caused during transportation or installation of the equipment. Equipment with scratches should not be exposed for an extended period.
- Do not perform operations such as arc welding and cutting on the equipment without the Company's evaluation.
- Do not install other devices on top of the equipment without an evaluation by the Company.
- When performing operations on top of the equipment, take steps to protect the equipment from damage.
- Use the correct tools and use them correctly.

## Moving heavy objects

- Use caution to avoid injury when moving heavy objects.
- If multiple people are to move a heavy object together, determine the labor force and division of labor by taking into account height and other conditions to ensure that the weight is distributed equally.

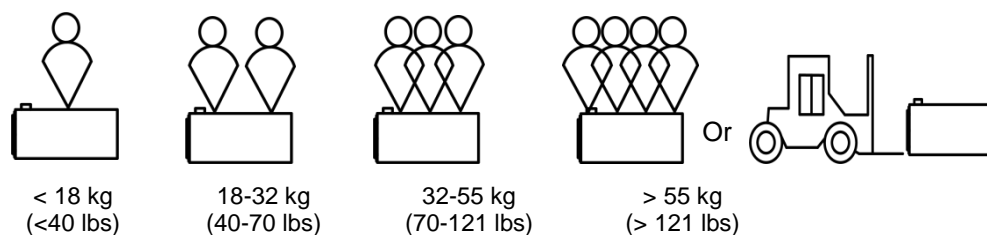

- If two or more people move a heavy object together, make sure that the object is lifted and landed at the same time and moved at an even speed under the supervision of one person.
- Wear personal protective equipment such as gloves and protective shoes when manually moving equipment.
- To move an object with your hands, approach the object, squat, and then lift the object gently and steadily with the strength of your legs instead of your back. Do not lift it suddenly or turn your body around.
- Do not quickly lift a heavy object above your waist. Place the object on a half-waist-high workbench or any other appropriate location, adjust the positions of your palms, and then lift it up.
- Move a heavy object stably with balanced force at an even, low speed. Lay the object down stably and loosely to avoid collision or falling due to scratching the surface of the equipment or damaging components and cables.
- When moving a heavy object, pay attention to the workbench, slope, stairs, and slippery spots. When moving a heavy object through a door, make sure the door is wide enough to move the object and avoid impact or injury.
- When transferring a heavy object, move your feet instead of turning your waist. When lifting and transferring a heavy object, make sure your feet are facing the desired direction of movement.
- When transporting equipment using a pallet jack or forklift, make sure the straps are properly positioned so that the equipment does not tip over. Before moving the equipment, attach it to the pallet truck or forklift using ropes. When moving equipment, assign dedicated personnel to take care of it.
- Choose the sea or roads in good condition for transportation. Do not transport the equipment by rail or air. Avoid tilting or jolting during transport.

### Using Stairs

- Use insulated and certified ladders when carrying out live line work at height.
- Platform ladders with protective railings are preferred. The use of single ladders is not recommended.
- Follow the instructions of the safety officer for the planning and execution of the installation
- Before using a ladder, make sure it is intact and check its load capacity.
- Make sure the ladder is securely positioned and held securely as per the ladder manufacturer's manual.
- When using a stepladder, make sure that the pull ropes are secured.
- If using a single ladder, make sure the wider end is at the bottom and take protective measures to prevent the ladder from slipping.
- If using a single ladder, do not climb higher than the fourth rung of the ladder from the top.
- If you are using a single ladder to climb a platform, make sure that the ladder is at least 1 m higher than the platform and that it is constrained.
- Use fall restraints if you exceed 180 cm in height above the ground

### Holes

- Obtain consent from the client and contractor before drilling holes.
- Wear protective equipment such as safety glasses and protective gloves during practice.
- To avoid short circuits or other hazards, do not drill holes in buried pipes or cables.
- When drilling holes, protect the equipment from chips. After drilling, clean any chips.

## Battery Safety



### DANGER

- Do not connect the positive and negative terminals of a battery. Otherwise, the battery may be short-circuited. Battery shorts can generate high instantaneous current and release a lot of energy, which can cause battery leakage, smoke, release of flammable gases, thermal runaway, freedom, or explosion. To avoid battery short-circuits, do not service batteries with batteries switched on.
- Do not expose batteries to high temperatures or near heat sources, such as scorching sunlight, accessible sources, transformers, and heaters. Overheating the battery may cause leakage, smoke, release of flammable gases, thermal runaway, fire, or explosion.
- Protect batteries from mechanical vibrations, drops, collisions, punctures, and strong shocks. Otherwise, the batteries may be damaged or catch fire.
- To avoid leakage, smoke, release of flammable gases, thermal runaway, absence or explosion, do not disassemble, alter or damage batteries; For example, insert foreign objects into batteries, squeeze batteries, or immerse batteries in water or other liquids.
- Do not touch the battery terminals with other metal objects, which may cause heat or electrolyte leakage.
- There is a risk of fire or explosion if the battery model being used or used for replacement is incorrect. Use a battery model recommended by the manufacturer.
- The electrolyte of the battery is toxic and volatile. Do not come into contact with spilled liquids or inhale gas if the battery leaks or smells. In such cases, stay away from the battery and contact professionals immediately. Professionals should wear safety goggles, rubber gloves, gas masks, and protective clothing, turn off the equipment, remove the battery, and contact technical engineers.
- A battery is a closed system and does not release gases during normal operation. Suppose a battery is improperly treated, such as burned, punctured, crushed, struck by lightning, overcharged, or subjected to other adverse conditions that can cause the battery to become thermally unstable. If this occurs, the battery may be damaged or an abnormal chemical reaction may occur inside the battery, resulting in loss of electrolyte or production of gases such as CO and H<sub>2</sub>. Ensure that the flammable gas is properly discharged to prevent fire or corrosion of the device.
- The gas generated by a burning battery can irritate the eyes, skin, and throat. Take protective measures promptly.



### ATTENTION

- 
- Install the batteries in a dry place. Do not install them under areas prone to water leakage, such as air conditioner vents, ventilation vents, machine room supply windows, or water pipes. Make sure that no liquid enters the equipment to prevent failure or short circuit.
  - Before unpacking, storing and transporting, make sure that the packing crates are intact and that the batteries are correctly positioned according to the labels on the packing cases. Do not place the battery upside down or vertically; Lay it on its side or tilt it. Stack the batteries according to the stacking requirements on the packaging cases. Make sure the batteries do not fall or become damaged. Otherwise, they will have to be scrapped.
  - After unpacking the batteries, place them in the desired direction. Do not place the battery upside down or vertically. Lay it on its side, tilt or stack it. Make sure the batteries do not fall or become damaged. Otherwise, they will have to be scrapped.
  - Tighten the screws on copper bars or cables to the torque specified in this document. Periodically check if the screws are tightened, check for rust, corrosion, or other foreign objects, and clean them if present. Loose screw connections will cause excessive voltage drops, and batteries can catch fire when the current is high.
  - After the batteries are discharged, charge them in time to avoid damage due to over-discharge.
-

## Information

**The Company shall not be liable for any damage to the battery, personal injury, death, loss of property, and other consequences caused by the following reasons:**

- Force majeure such as earthquakes, floods, volcanic eruptions, debris flows, lightning, fires, wars, armed conflicts, typhoons, hurricanes, tornadoes, and other extreme weather conditions
  - The battery warranty period has expired. It is recommended that you do not use a battery with an expired warranty period, as this poses safety risks.
  - Actions that do not follow the instructions in the user manual or the Company's direct advice, including but not limited to the following scenarios:
    - The operating environment of the on-site equipment or the external power supply parameters do not meet the environmental requirements for smooth operation; For example, the actual operating temperature of the batteries is too high or too low, or the power grid is unstable and experiences frequent outages.
    - The batteries have been dropped or have not been used or connected properly.
    - Batteries are overcharged due to a delay in acceptance or ignition after the battery is installed.
    - The battery operating parameters are set incorrectly.
    - Different types of batteries, such as batteries of different brands or capacities or old and new batteries, are used together without prior approval from the Company.
    - Do not use batteries other than the WeCo SMART model, there is no other compatibility except for the WeCo SMART SERIES batteries with DCDC 450Vdc
    - Batteries are often damaged due to improper maintenance.
    - Battery usage scenarios are changed without prior approval from the Company.
    - Battery maintenance is not carried out according to the instructions in the user manual, such as not checking the battery terminals regularly.
    - Batteries are not transported, stored, or charged in accordance with the instructions in the user manual.
    - The company's instructions are not followed when repositioning or reinstalling the battery.
- It is recommended to purchase a battery with an expired product warranty period.

## General requirements

### NOTICE

**To ensure battery safety and accurate battery handling, use batteries provided by the Company. The Company is not responsible for any failure of batteries not supplied by it.**

- Before installing, operating, and maintaining batteries, read the manufacturer's instructions and comply with the relevant requirements. The safety precautions specified in this document are essential and require special attention. For additional safety precautions, please refer to the instructions provided by the battery manufacturer.
- Use batteries within the specified temperature range. When the ambient temperature of the batteries is lower than the permissible range, do not charge the batteries to avoid internal short circuits caused during low-temperature charging.
- Although the battery is equipped with a heating system, it is always advisable to install the battery in a temperate place in order to ensure a longer period of operation and efficiency over time.
- Before unpacking the batteries, check that the packaging is intact. Do not use batteries with damaged packaging. If any damage is found, notify the carrier and manufacturer immediately.
- Turn on the newly installed batteries and check that they are working properly.
- If the batteries cannot be activated, place them in the original packaging and store them in a dry indoor environment free of corrosive gases.
- Do not clean the storage system with solvents or fuels, gases may ignite
- Do not store fuels or gases in or near the storage system

- Do not use a damaged battery (e.g. damage caused by a battery falling, bumping, swelling, or denting on the casing) because damage may cause electrolyte leakage or release of flammable gases. In the event of electrolyte leakage or structural deformation, contact the installer or professional O&M personnel immediately to remove or replace the battery. Do not store the damaged battery near other flammable devices or materials; Keep it out of the reach of non-professionals.
- Before working on a battery, make sure there are no irritating or burnt odors around the battery.
- When installing batteries, do not place installation tools, metal parts, or miscellaneous items on the batteries. After installation, clean the items on the batteries and the surrounding area.
- If the batteries are accidentally exposed to water, do not install them. Instead, transport the batteries to a safe isolation point and dispose of them promptly.
- Before installing a battery pack, make sure that the enclosure is not deformed or damaged.
- Check whether the positive and negative terminals of the battery are grounded unexpectedly. If this occurs, disconnect the battery terminals from the ground.
- Do not perform welding or grinding work around the batteries to avoid fire caused by electric sparks or arcing.
- If batteries are left unused for an extended period, store and charge according to battery requirements and follow the manufacturer's instructions, batteries stored at low or high temperature may have suffered damage, consult the manufacturer before using or recharging
- Do not charge or discharge batteries using a device that does not comply with WeCo requirements and/or local laws and/or regulations.
- Keep the battery circuit disconnected/open during installation and maintenance.
- Monitor batteries damaged during storage for signs of smoke, flame, electrolyte leakage, or heat.
- If a battery is defective, its surface temperature may be high. Do not touch the battery to avoid scalding.
- Do not stand on, lean on, or sit on the equipment.
- In backup power layouts, do not use batteries for the following situations:
  - Medical devices that are essentially crucial for human life
  - Control equipment such as trains and elevators, as this can cause personal injury
  - Information systems of social and public importance
  - Medical and/or life-saving devices
  - Other devices similar to those described above

#### **Short circuit protection**

- When installing and servicing batteries, wrap the exposed cable terminals in the batteries with electrical tape.
- Do not allow foreign objects (such as conductive objects, screws, and liquids) to enter a battery, as this may cause short circuits.

## **Recycling**

- Dispose of used batteries according to local laws and regulations. Do not dispose of batteries as household waste. Improper disposal of batteries may result in environmental pollution or explosion.
- If a battery leaks or is damaged, contact technical support or a battery recycling company for disposal.
- Do not incinerate.
- Do not discard in generic battery baskets.
- Do not dispose of or submerge batteries in water or liquid.
- If batteries are out of use, contact a recycling company for disposal.
- Do not expose used batteries to high temperatures or direct sunlight.
- Do not place used batteries in environments with high humidity or corrosive substances.
- Do not use defective batteries. Contact a battery recycling company to scrap them as soon as possible to avoid environmental pollution.

## Guide

- This document describes the user manual of The Storage System for the convenience of users.
- This document focuses on product features, configuration, component introduction, and maintenance guidance for the SMART Series inverter and battery
- Before using and maintaining the product, read and remember the instructions and notes in the document.
- SMART batteries and inverters cannot be used with other inverters or batteries. The Sete Smart Inverter should only be used with WeCo-approved batteries.
- Before using this document, collect data on each component for future use.
- The graphics in this document are for illustration purposes only. Please refer to the actual product on site for the specific appearance of the product.
- The relevant precautions in this document only supplement the laws and regulations in force in the country

**This manual must be left with the end user and the latter must be trained and informed about the maintenance, supervision, risks and obligations arising from the installation of this system**

## 2 Product Introduction

### 2.1 Overview

The energy storage system, including inverters and battery expansion modules, can store and release electricity according to the high-performance energy management system for solar energy, battery, load and grid system management.

The Storage System conveniently and intuitively displays the operating status and parameter change via the app and supports various working modes for greater ease of use.

The system The Storage System supports power and capacity expansion, supports 4 inverter modules in parallel and one inverter module supports up to 4 battery expansion modules.

### 2.2 Model

#### System

The identification of the product model is as follows.

Table 3-1 System Model Descriptions

No.	Meaning	Description
1	Battery Capacity for Single-Phase System	5K0: 5 kWh
2	Product series	Smart Series
3	Market	EU: European market
4	Inverter type	Monophase
5	Inverter power	3 kW 3.6 kW 4.6 kW 5 kW 6 kW
6	Battery energy available per tower (4 MAX batteries per tower, 12 batteries MAX parallel)	5 kWh 10 kWh 15 kWh 20 kWh

## 2.3 Appearance

The appearance of the product is shown as follows

Figure 3-3 Overall System Appearance

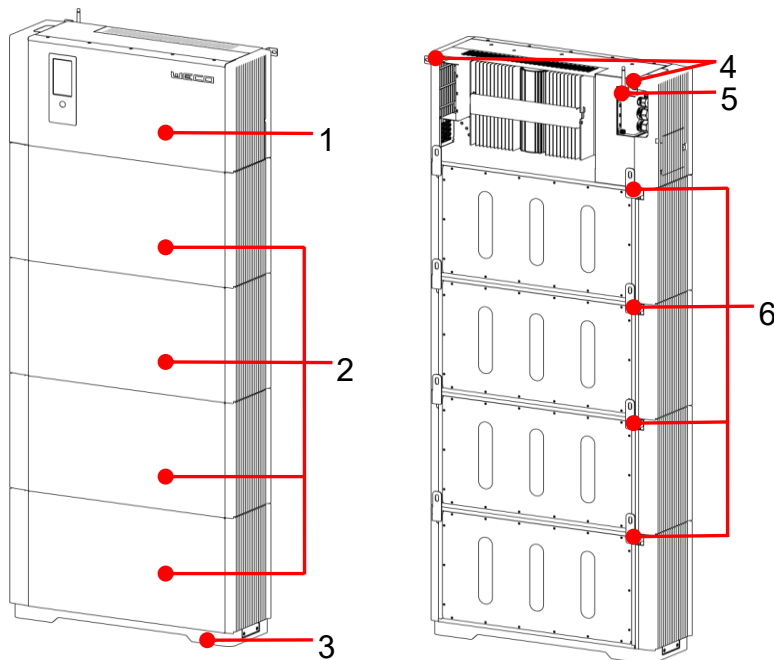

1: Inverter module	2: Battery Extension Module	3: Battery Base
4: L-shaped bracket for inverter fixing	5: WiFi Module	6: Battery Wall Mounting

## 2.4 Label

The label mainly contains information such as the brand and model of the product, important technical parameters, the logo of the certification system it complies with, the name of the company and the place of origin.

See label on the product to determine the technical data and the date of production; Below is an example:

WECO 5KO Smart		WECO 5KO Smart		WECO 5KO Smart	
Model	SMART-14K215	SMART-15K215	SMART-16K215	Model	SMART-14K215
<b>PV input</b>				<b>PV input</b>	
Max. PV input power	9.2 kW	10 kW	10 kW	Max. PV input power	10 kW
Max. PV input voltage	580 Vdc	580 Vdc	580 Vdc	Max. PV input voltage	580 Vdc
MPPT operating voltage	80 – 520 Vdc	80 – 520 Vdc	80 – 520 Vdc	MPPT operating voltage	80 – 520 Vdc
Max. input current per MPPPT	16 Adc	16 Adc	16 Adc	Max. input current per MPPPT	16 Adc
Max. Isc per MPPPT	20 Adc	20 Adc	20 Adc	Max. Isc per MPPPT	20 Adc
Number of MPPPT Racklers	2	2	2	Number of MPPPT Racklers	2
<b>AC input / output (single)</b>				<b>AC input / output (single)</b>	
Rated input / output voltage	230 Vac L/N/PE, Single Phase	230 Vac L/N/PE, Single Phase	230 Vac L/N/PE, Single Phase	Rated input / output voltage	230 Vac L/N/PE, Single Phase
Rated input / output power	4.6 kW	5 kW	5 kW	Rated input / output power	5 kW
Rated input / output current	20 Aac	21.7 Aac	21.7 Aac	Rated input / output current	26 Aac
Frequency	50 / 60 Hz	50 / 60 Hz	50 / 60 Hz	Frequency	50 / 60 Hz
<b>AC output (back-up)</b>				<b>AC output (back-up)</b>	
Rated output voltage	230 Vac	230 Vac	230 Vac	Rated output voltage	230 Vac
Rated output power	4.6 kW	5 kW	5 kW	Rated output power	6 kW
Rated output current	20 Aac	21.7 Aac	21.7 Aac	Rated output current	26 Aac
Frequency	50 / 60 Hz	50 / 60 Hz	50 / 60 Hz	Frequency	50 / 60 Hz
<b>GEN input</b>				<b>GEN input</b>	
Rated input voltage	230 Vac	230 Vac	230 Vac	Rated input voltage	230 Vac
Rated input power	4.6 kW	5 kW	5 kW	Rated input power	6 kW
Rated input current	20 Aac	21.7 Aac	21.7 Aac	Rated input current	26 Aac
Frequency	50 / 60 Hz	50 / 60 Hz	50 / 60 Hz	Frequency	50 / 60 Hz
<b>Battery (Built-in BDCDC)</b>				<b>Battery (Built-in BDCDC)</b>	
Battery type	LiFePO4	LiFePO4	LiFePO4	Battery type	LiFePO4
Rated voltage	430 Vdc	430 Vdc	430 Vdc	Rated voltage	430 Vdc
Number of battery module	2	3	4	Number of battery module	3
Max. charge / discharge current	12 Adc	15 Adc	15 Adc	Max. charge / discharge current	15 Adc
Nominal available capacity	10 kWh	15 kWh	20 kWh	Nominal available capacity	15 kWh
<b>General</b>				<b>General</b>	
Enclosure	IP65	IP65	IP65	Enclosure	IP65
Max. operating altitude	3000 m	3000 m	3000 m	Max. operating altitude	3000 m
Operating temperature / humidity	-20°C ~ +50°C / 0 - 95% RH	-20°C ~ +50°C / 0 - 95% RH	-20°C ~ +50°C / 0 - 95% RH	Operating temperature / humidity	-20°C ~ +50°C / 0 - 95% RH
Protective class	Class I	Class I	Class I	Protective class	Class I
WECO S.R.L. Made in China Viale Kennedy 113-121 Scarperia e San Piero, Firenze, Italy			WECO S.R.L. Made in China Viale Kennedy 113-121 Scarperia e San Piero, Firenze, Italy		
SN: XXXXXXX XXXX XXXXX XXX			SN: XXXXXXX XXXX XXXXX XXX		

## 2.5 Technical specifications

### System

- The specification parameters of the EUS 025 Storage System series are shown as follows.

**Table 33 Specification Parameters of the Series The EUS 025 Storage System**

- The specification parameters of the EUS 030 Storage System series are as follows.

**Table 34 Specification parameters of the series The EUS 030 Storage System**

Elements	Parameter		
Model	See AC Power		
<b>PV Input</b>			
Max. PV Input Power	Up to 200% of AC inverter power (150% for 6kW version)		
PV input voltage max.	580 V DC		
MPPT Operating Voltage	80 – 520 VDC		
Maximum input current for MPPT	16A		
Max. Isc for MPPT	20A		
Number of MPPT trackers	2		
<b>AC input/output (networked)</b>			
Rated Input/Output Voltage	230 Vac L/N/PE, single-phase		
Input/output power rating	See product plate		
Rated Input/Output Current	See product plate		
Frequency	50 / 60 Hz		
<b>AC Output (Backup)</b>			
Rated Output Voltage	230 V AC		
Rated Output Power	Equal to the minimum power between batteries connected to inverters		
Rated Output Current	See Inverter rated power and number of connected batteries		
Frequency	50 / 60 Hz		
<b>GEN Input</b>			
Nominal input voltage	230 V AC		
Rated input power	See product plate		
Rated input current	See product plate		
Frequency	50 / 60 Hz		
<b>Battery (built-in DCDC)</b>			
Battery type	LiFePO <sub>4</sub>		
Voltage rating	450 V		
Number of battery modules (minimum one battery module)	2	3	4
Usable energy	10 kWh	15 kWh	20 kWh
<b>General</b>			
Maximum Operating Altitude	3000 m above sea level		
Operating temperature/humidity	-20~50°C / 0 - 95% RH		
Protection class	Class I		

## 3 Introduction to components

### 3.1 Inverter module

#### 3.1.1 Appearance

The appearance of the inverter module without the decorative cover is shown as follows. 615mm\*210mm\*330mm

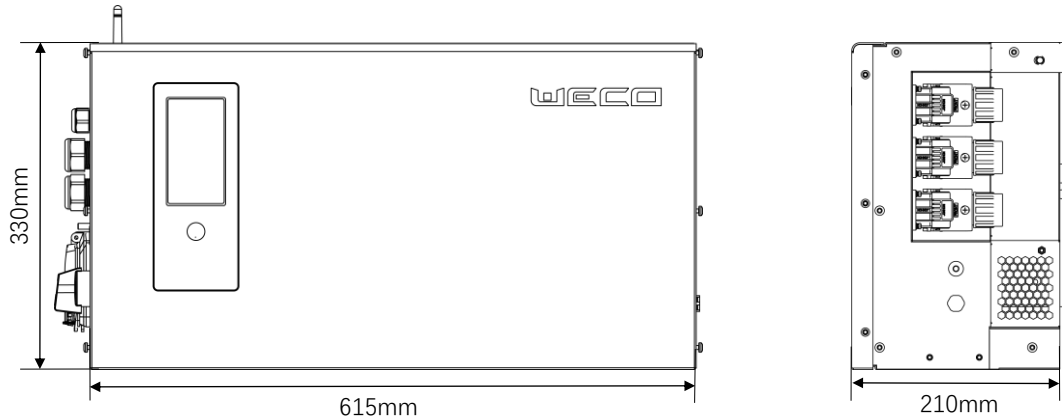

Figure 4-1 The Appearance of the Inverter Module Without Decorative Covers

#### 3.1.2 Control panel

The inverter module control panel is shown as follows.

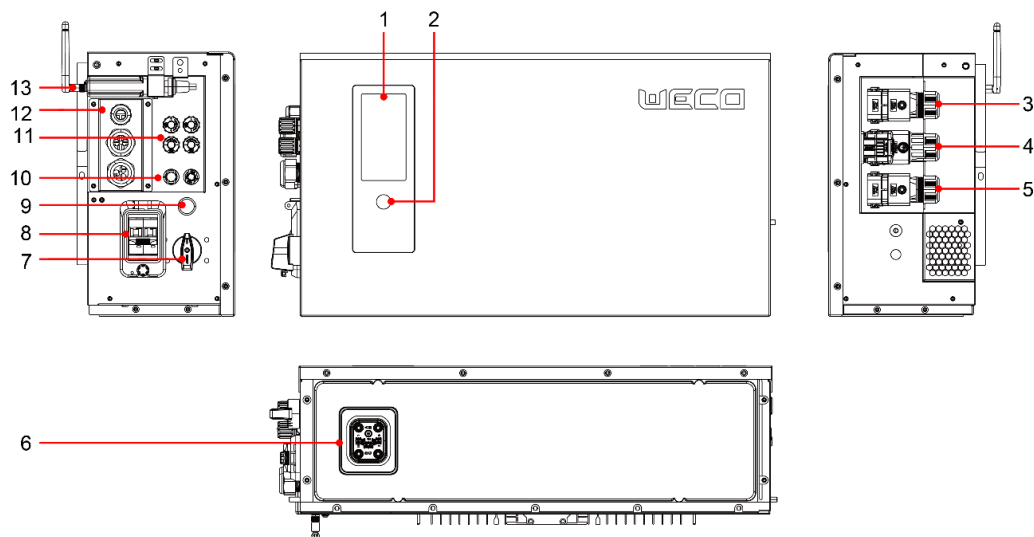
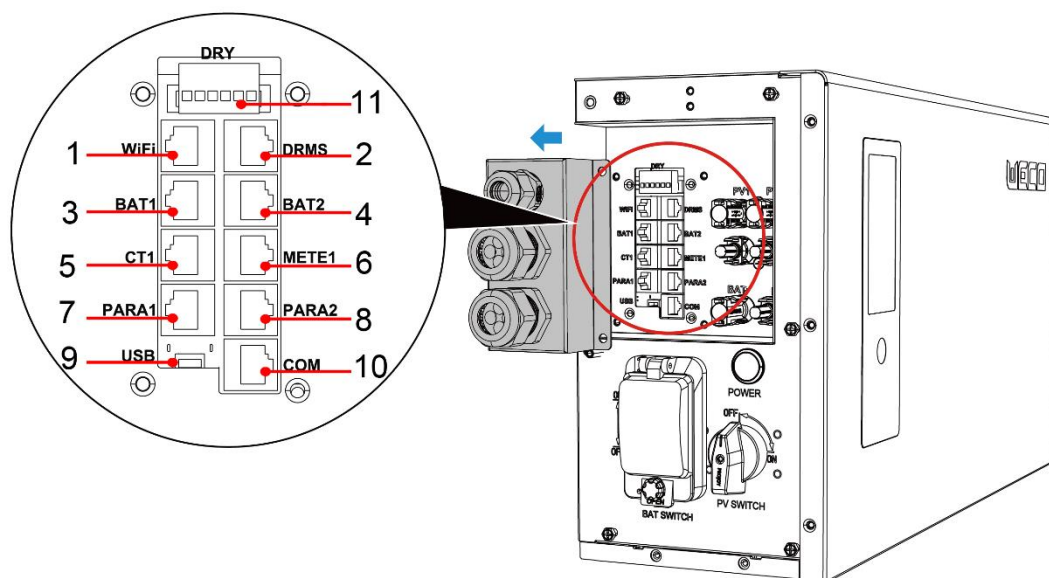

Figure 4-2 Inverter Module Control Panel

1: Screen	2: Working indicator and power off button	3: BACKUP UP (Standby Power Load Interface)
4: GEN (Generator Interface)	5: GRID (Utility Interface)	6: Battery stacking interface
7: PV Switch	8: Battery DC Switch	9: Switch button
10: DC Battery Expansion Interface	11: PV Interface	12: Communication Interface
13: WiFi Module		

The control panel of the communication interface of the inverter module is shown as follows.



**Figure 4-3 Inverter Module Communication Interface Operation Panel**

The communication interface ports of the inverter module are shown as follows.

**Table 4-1 Inverter Module Communication Interface Ports**

NO.	Elements	Parameter
1	Wi-Fi connection	RS485 / RS232S (upgrade port)
2	DRMS	Parallel grid port
3	BAT1	Parallel port 1/CAN battery
4	BAT2	Parallel battery port 2 / CAN
5	CT1	Current Transformer Port 1 / Meter Communication Port
6	TIME1	Communication port for smart meters
7	PARA1	Inverter parallel signal input port
8	PARA 2	Inverter parallel signal output port
9	USB	Firmware Updater Port
10	COM	Battery master communication port (for parallel operation)
11	DRY	Dry node inlet/outlet port

## 3.2 Battery module

### Front and rear view

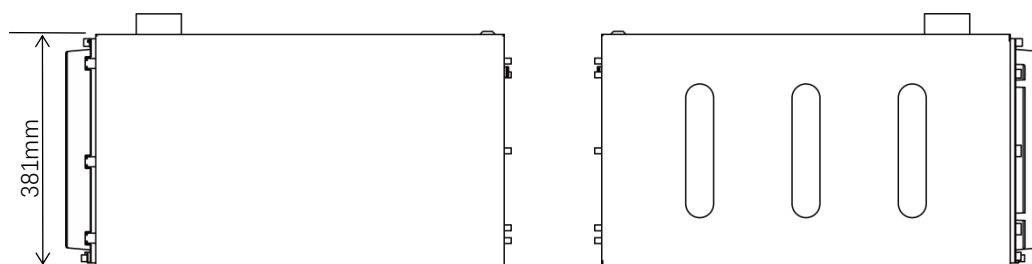

Figure 4-4

### Top and bottom view

The appearance of the battery expansion module with a decorative cover is shown as follows.

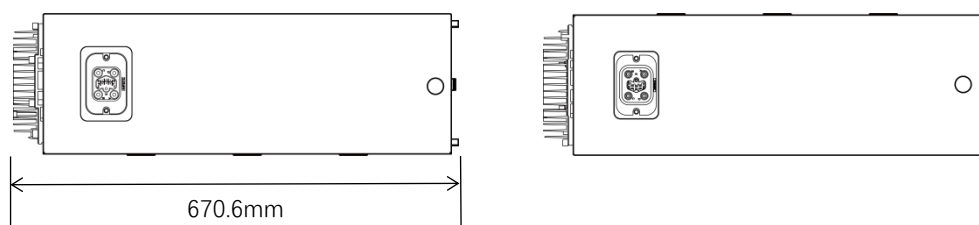

Figure 4-5

### Left and right view (without cover)

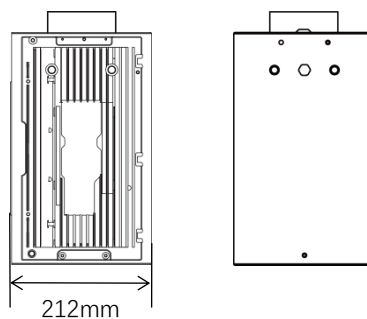
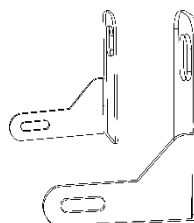

Figure 4-6



Bracket for fixing the battery to the wall

### 3.3 Battery base

The appearance of the battery base is shown as follows.

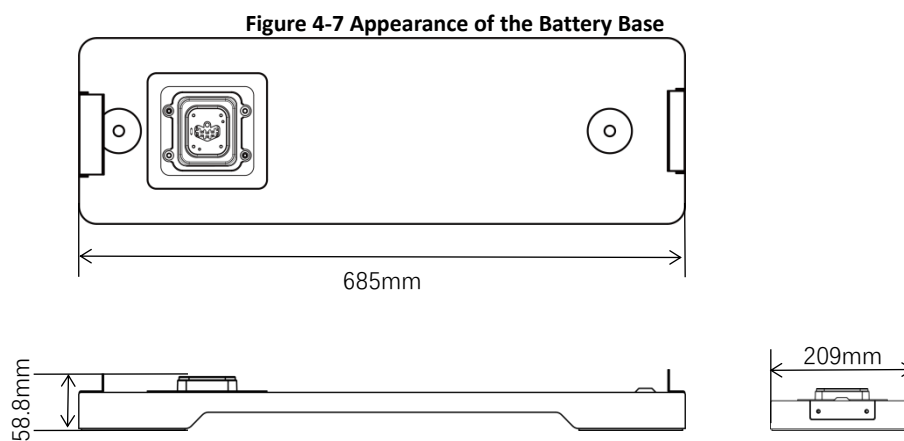

## 4 System Installation

### 4.1 Preparing for Installation

#### 4.1.1 Product acceptance

After receiving the goods, please check that the packing box is intact and inspect the contents immediately. If the packaging box is damaged, it is important to sign a reservation right to the carrier and indicate the degree of damage. We recommend that you refuse the goods if the damage is severe.

It is recommended that you unpack and inspect the goods without delay. If you find that the goods you receive do not match what is listed on the delivery list, contact your dealer and do not start the installation procedure.

#### 4.1.2 Packing slip

After unpacking the battery, it is critical to verify that the products are intact, complete, and free of obvious damage. If any items are missing or damaged, please contact your retailer, making sure you have the document accompanying the goods.

Below is the packing list of the inverter module.

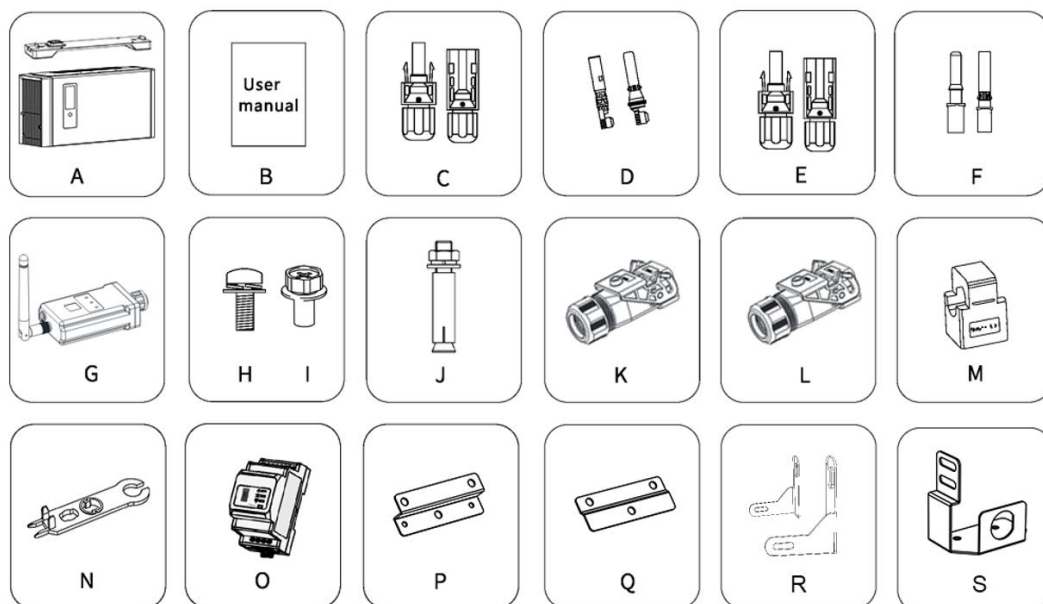

Figure 5-1 Inverter Module Packing List

No.	Description	Quantity
At	Inverter module + battery BASE	1
B	Manual	1
C	PV+ connector	2
D	PV+Pin Connector	2
And	PV - connector	1
F	PV-pin connector	1
G	WiFi Module	1
H	M4*10 Recessed Cross Head Carriage Screws with Washer	8
I	M6*10 Cross Head Hex Head Cap Cap Screws with Recessed Tip	3
J	M6*60 Expansion Bolt	2
K	AC-Black Connector	1
L	AC-Blue Connector	1
M	CT ( <i>*optional nin accordance with meter required or provided in the country</i> )	1
N	MC4 Snap Removal Tool	1
Or	Smart meter	1
P	Right battery stacking connector	1
Q	Left battery stacking connector	1
R	Inverter bracket L for wall mounting	2
S	WiFi fixing	1

The list of items required for the battery expansion module is as follows.

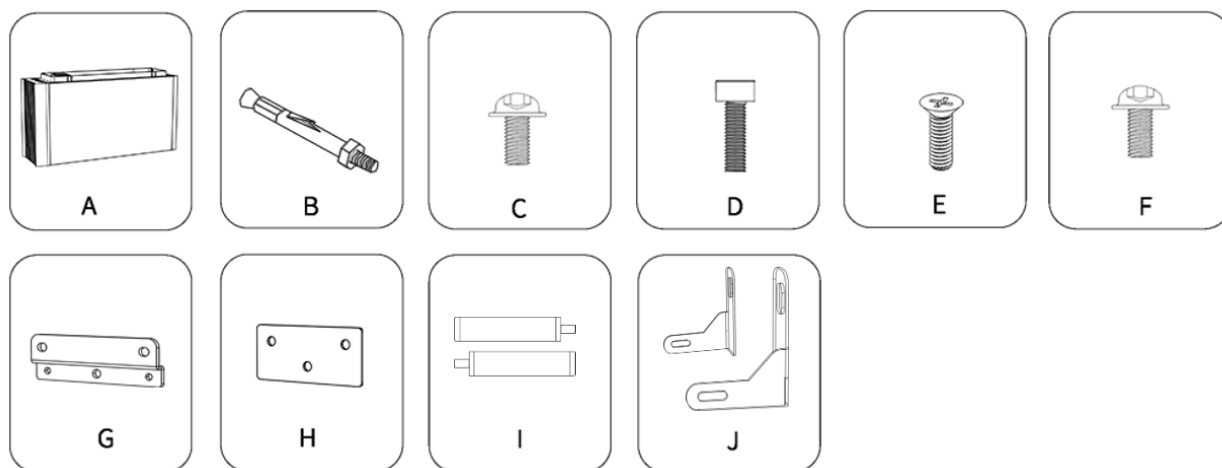

Figure 5-2 Battery Expansion Module Packing List

No.	Description	Quantity
A	Expansion Battery Module	1
B	M6 Expansion Bolt	2
C	M4*14 hexagon socket flat carriage screws with washer	2
D	M4*12 Hex Socket Head Cap Combo Screw	2
And	Phillips Countersunk Head Screw M5*10	2
F	M4*8 hexagon socket set screws with flat round head and washer	2
G	Fixing bracket for type A modules	1
H	Fixing bracket for type B modules	1
The	Handles (may have different shapes depending on the target market)	2
J	stirrup	1

## 4.2 Installation environment, space, and security requirements

### 4.2.1 Installation environment requirements

#### ! ATTENTION

**Only qualified professionals or trained personnel are allowed to install, operate, and maintain the equipment.**

- Selecting an appropriate location for the installation of the Storage System is essential to ensure correct and efficient operation. When choosing the mounting location, the following factors should be considered:
- The Storage System has IP65 degree of protection and can be used both indoors and outdoors. It is important that the ambient temperature remains below 40°C to ensure optimal operating conditions and extend the life of the device.
- The mounting method and location must be appropriate for the weight and size of the 5K0 Smart. Ensure that the walls are strong enough to meet the load requirements needed for the installation of the 5K0 Smart.
- The installation floor should be level, free of significant drop-offs or holes, to provide a stable foundation. The ground level must be 5 mm or less.
- Avoid installing the Storage System on drywall or similar walls that are poorly soundproofed and not solid, or in areas where it may cause obstruction or noise, as the noise emitted during operation may disturb residents.
- It is essential to install it in a well-ventilated environment to ensure proper heat dissipation. Also, do not expose the Storage System to direct sunlight, rain, or snow.

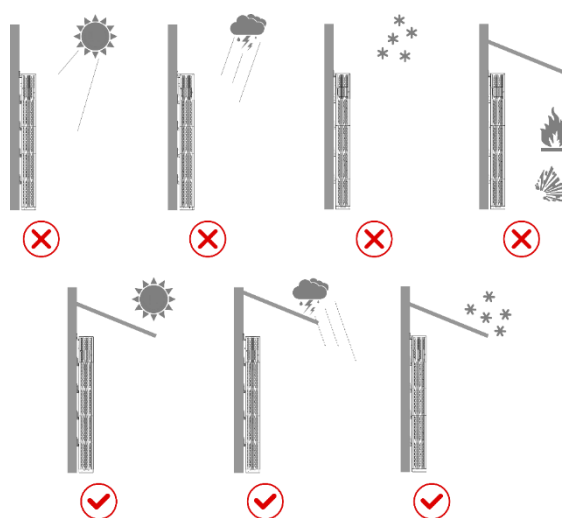

Figure 5-4 Installation Environment Requirements

## 4.2.2 Space requirements for installation

When installing, make sure that there are no other devices (except awnings, etc.) or flammable or explosive materials around the batteries. Reserve adequate space for heat dissipation and safety insulation.

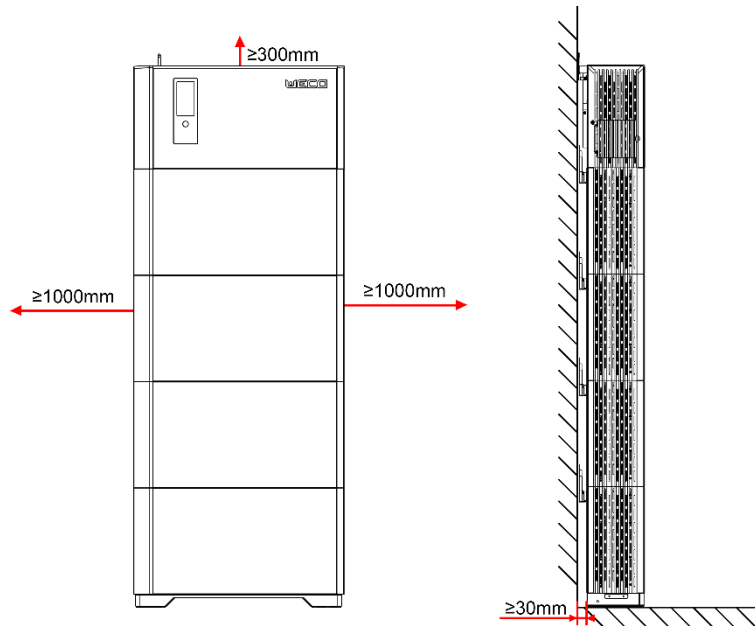

Figure 5-5 Installation Space Requirements

## 4.2.3 Safety requirements for installation

### **⚠ DANGER**

Avoid drilling holes in water pipes or power cables buried in the wall.

### **⚠ CAUTION**

- When installing the equipment, it is crucial to ensure that the installation surface is flat and solid enough to support the weight of the equipment. It is recommended that you avoid over-adjusting the adjustable leveling nuts of the floor mounting bracket. It is important to ensure that the nuts are engaged at least half the depth of the thread, so as to provide adequate stability. Over- or under-tightening could damage the screw threads, considering the significant weight of the energy storage module.
- Installation floor requirements: concrete floor. Requirements for wall installation: Please contact the installer for information regarding load-bearing walls with concrete and brick surfaces, with the exception of walls.
- The equipment is heavy; Therefore, it is advisable to keep the handles raised vertically during handling and to be careful not to drop/slip/lower the handles quickly, to prevent the equipment from falling and injuring the operator.

### **NOTICE**

- To avoid dust inhalation or eye contact, wear safety goggles and a dust mask when drilling holes.
- Use a vacuum cleaner to clean the dust in and around the holes and measure the distance. If the holes are positioned incorrectly, drill the holes again.
- Level the expansion sleeve head with the concrete wall or floor after removing the nut, spring washer, and flat washer. Otherwise, the mounting kit will not be securely installed on the wall or ground.

- Before installing an energy storage module, clean the ports on the base. In any case, make sure that both the upper and lower ports are dry and free of dust and foreign objects. Otherwise, the equipment may be damaged or short-circuit the battery and/or inverter
- Before tightening the screws on both sides of each module, make sure that the front panels of the modules are flush with each other.

## 4.3 Installation Steps

### Physical installation

1. Install base: fix the base to the ground with suitable dowels
2. Stack\* the first battery and fix it to the wall with the supplied brackets
3. Stack\* any other batteries and fix them to the wall with the supplied brackets
4. Install\* the inverter and secure it with the inverter brackets

\*\*\* the batteries must be secured together with their side brackets in addition to the wall mounting brackets

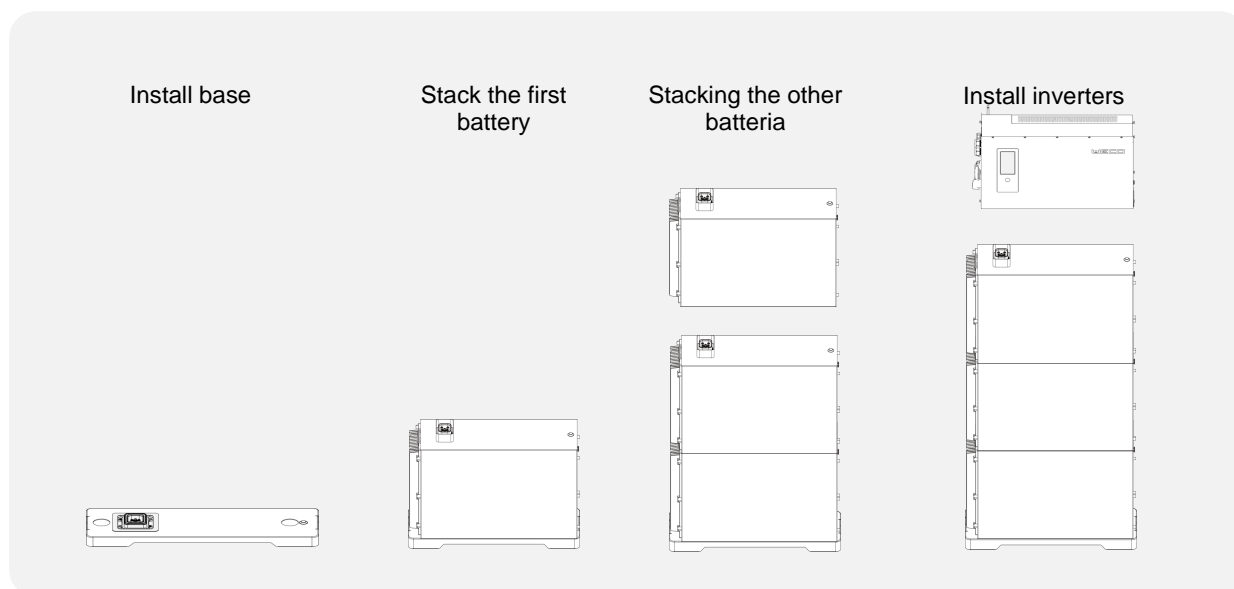

Figure 5-6 Installation Steps

### 4.3.1 Step 1. Install the base.

1. Place the base parallel to the wall
2. Leave the base 30 mm away from the wall.
3. Level the base, mark the base mounting holes with a marker, and drill holes with a hammer drill.

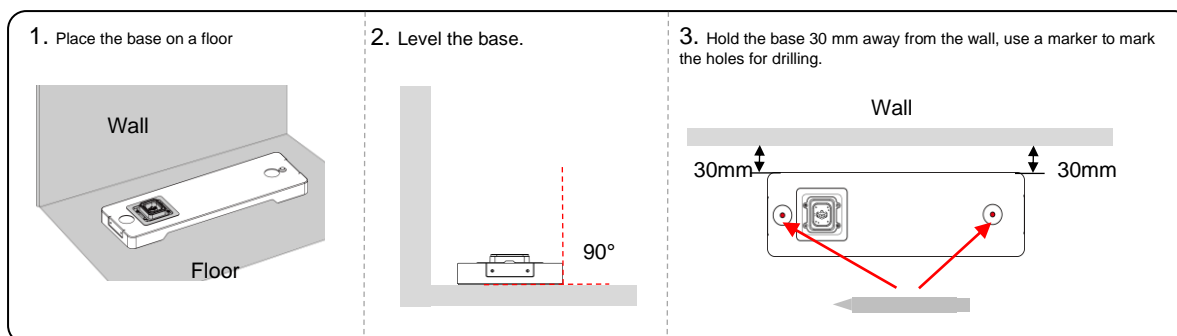

Figure 5-7 Installing the Base Module

After leveling the battery base with a tool, secure it with the expansion bolts.

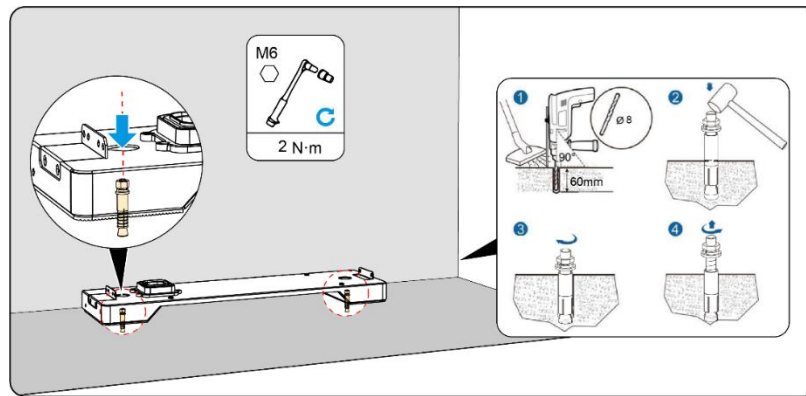
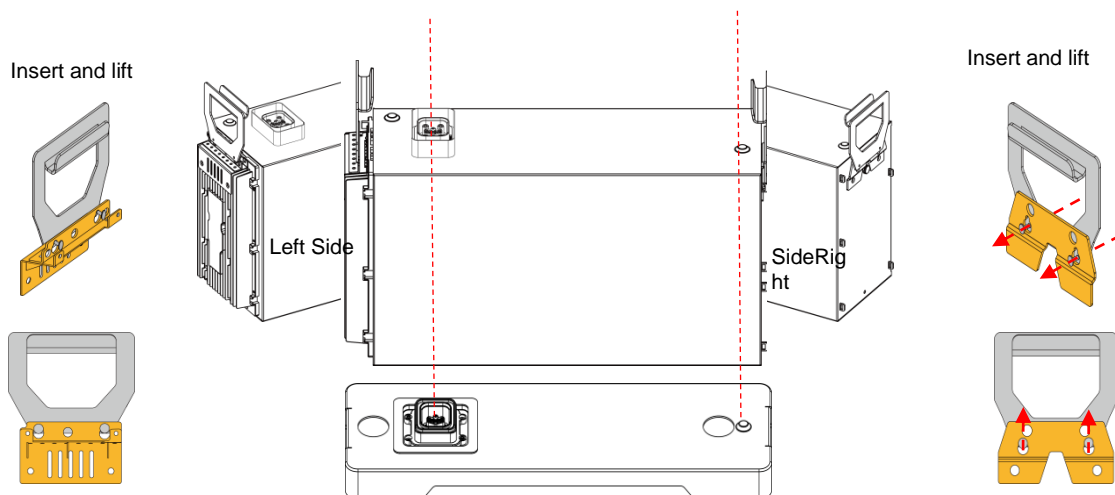

Figure 5-8 Attach the Base to the Floor

### 4.3.2 Step 2. Stack the first battery module on the base

A. Take the handle out of the battery pack, insert the handles on the sides of the battery module.

Figure 5-9 Battery Module Installation



B. Align the battery with the base module, place the battery on top of the base, make sure the socket connects to the head, the female socket -connects to the male plug, and then pull out the handles.

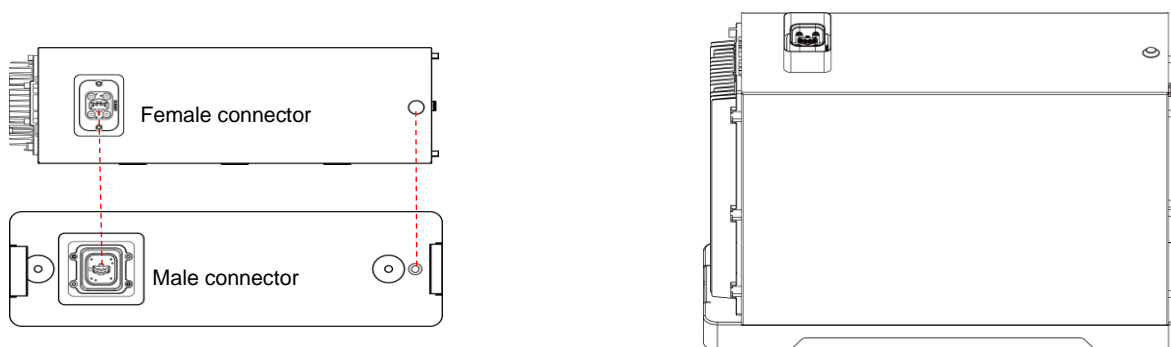

Figure 5-10 Pull Out the Handles

C. Take the brackets from the basic package. Attach the left base bracket on the left side between the battery module and the base module.

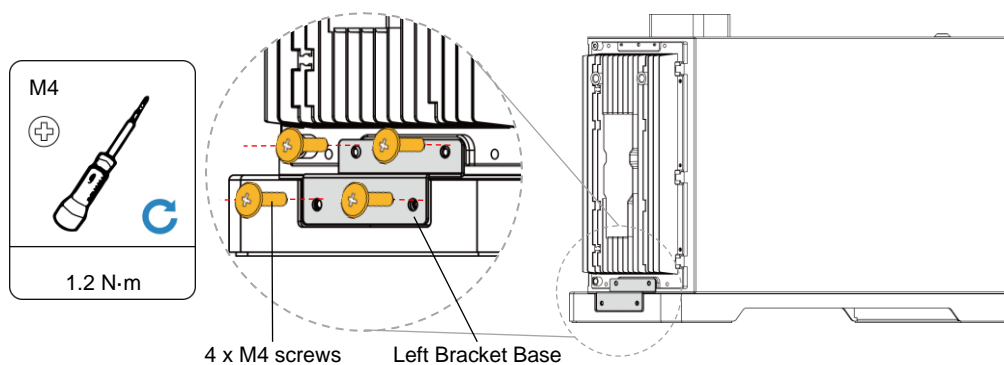

Figure 5-11 Installing the Left Side Battery Bracket

D. Attach the right base bracket on the left side between the battery module and the base module.

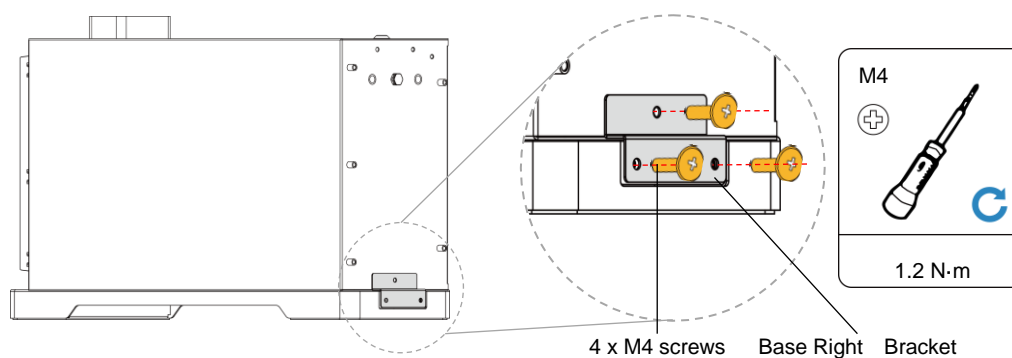

Figure 5-12 Installing the Right Side Battery Bracket

E. Take the bracket out of the battery pack, place the left wall bracket in the correct position, and then use a marker to mark the marks for drilling the holes.

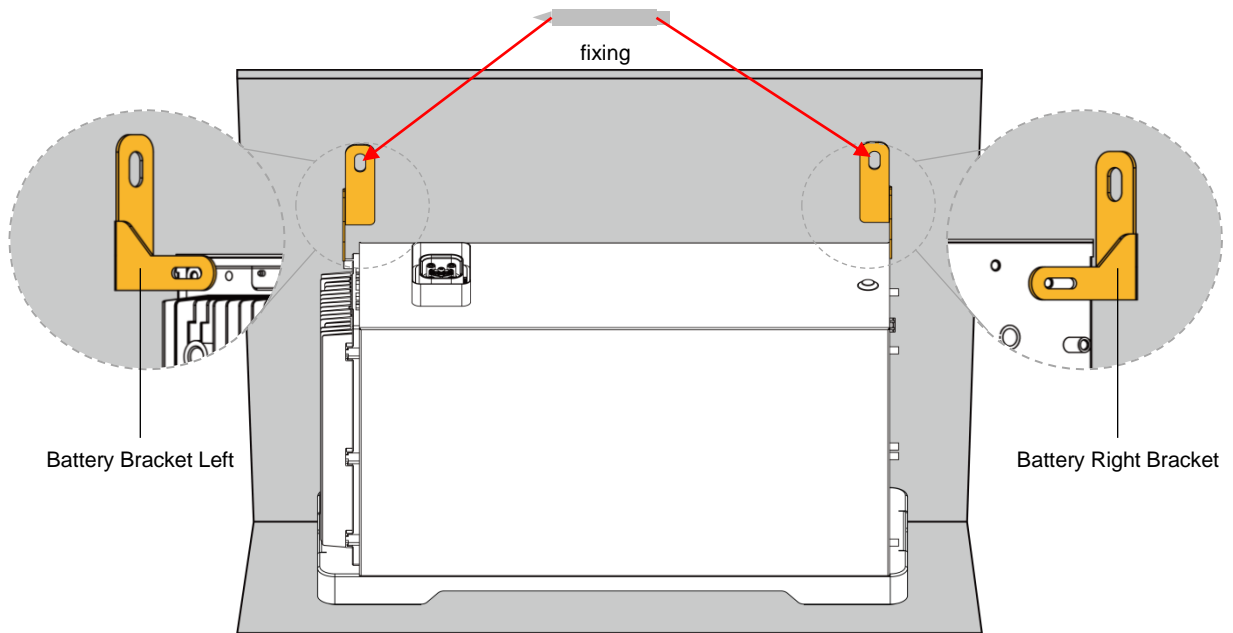

Figure 5-13 Mark the Holes

F. Drill holes for wall brackets, install bolts, pull out nuts.

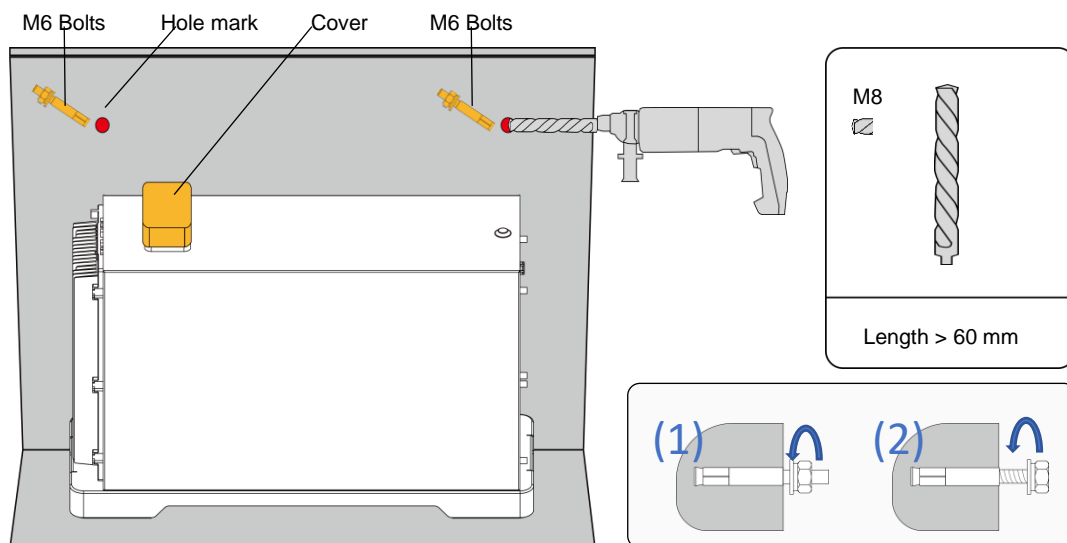

Figure 5-14 Wall Bracket Holes

G. Place the wall bracket on the wall and bolts, tighten the nuts to secure the bracket to the wall and inverter.

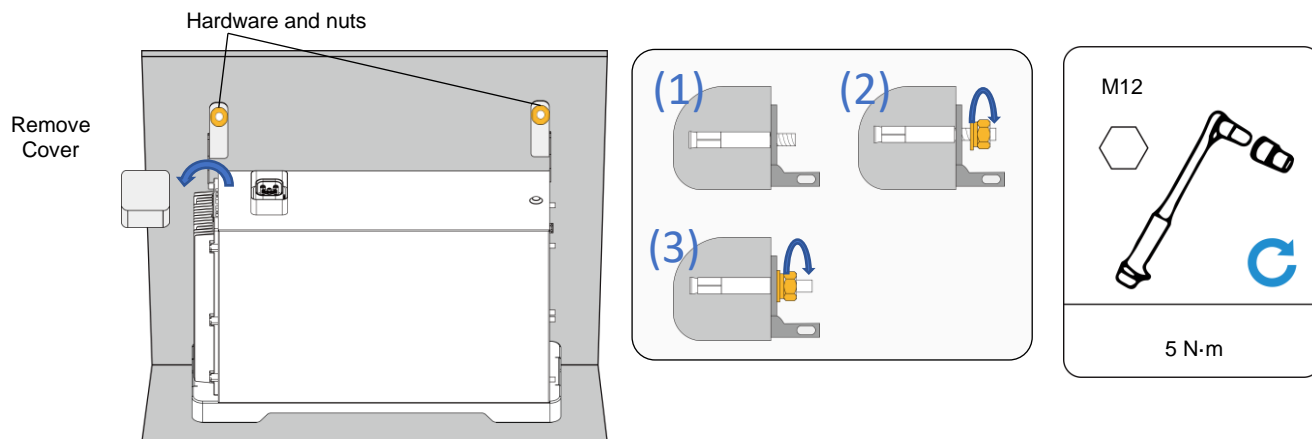

Figure 5-15 Attach the Wall Brackets

### 4.3.3 Step 3. Stack the second one and rest the battery module.

A. Perform the same steps as in "Step 2-A", take the handles from the package, insert the handles on the sides of the battery module, stack the second battery on top of the first battery, take out the handles.

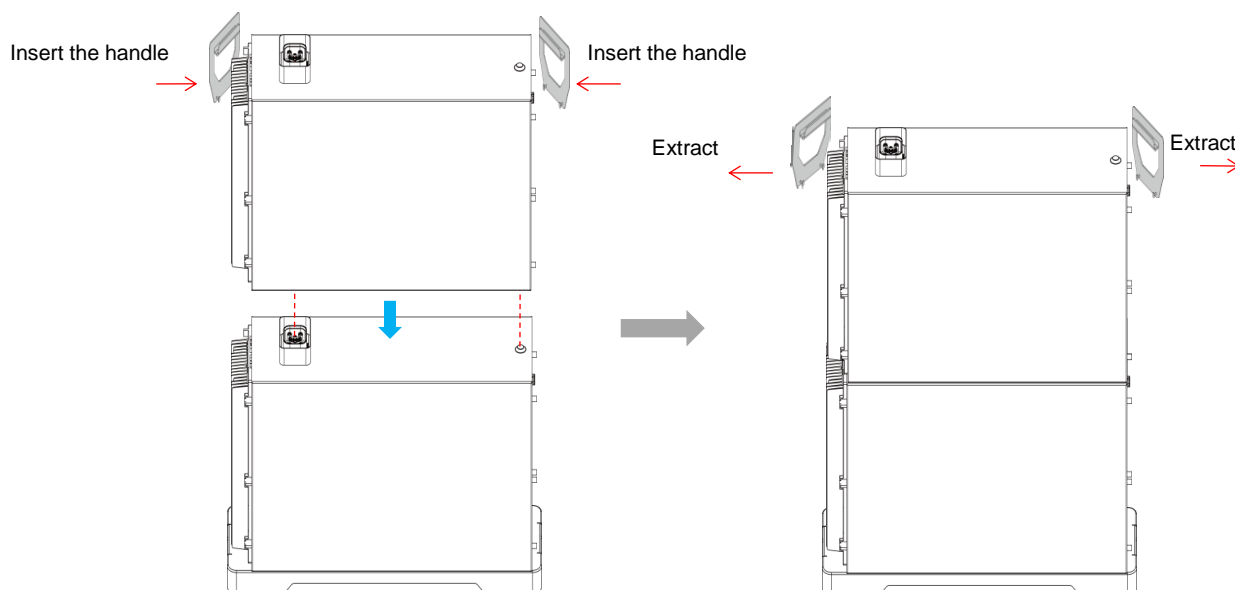
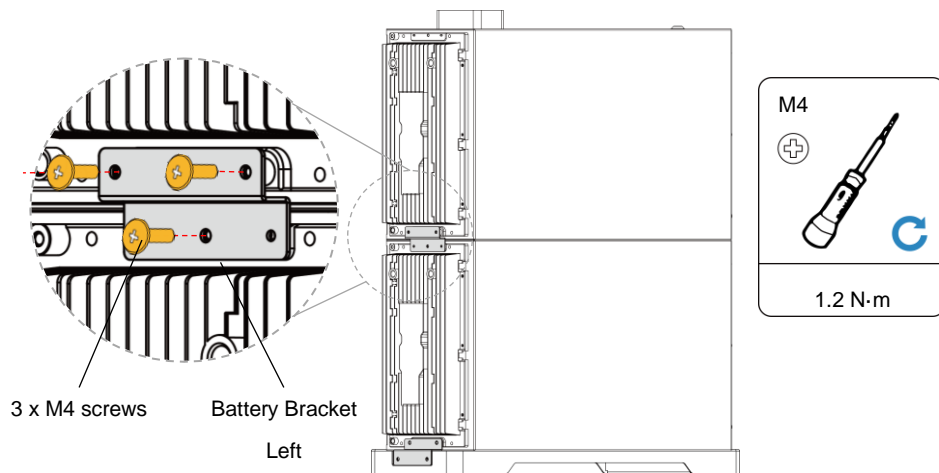

Figure 5-16 Stacking the Inverter Module

B. Take the brackets out of the battery pack. Attach the left battery bracket on the left side between the battery module and the battery module.



**Figure 5-17 Installing the Battery on the Left Side Bracket of the Battery**

C. Attach the right battery bracket on the right side between the battery module and the battery module.

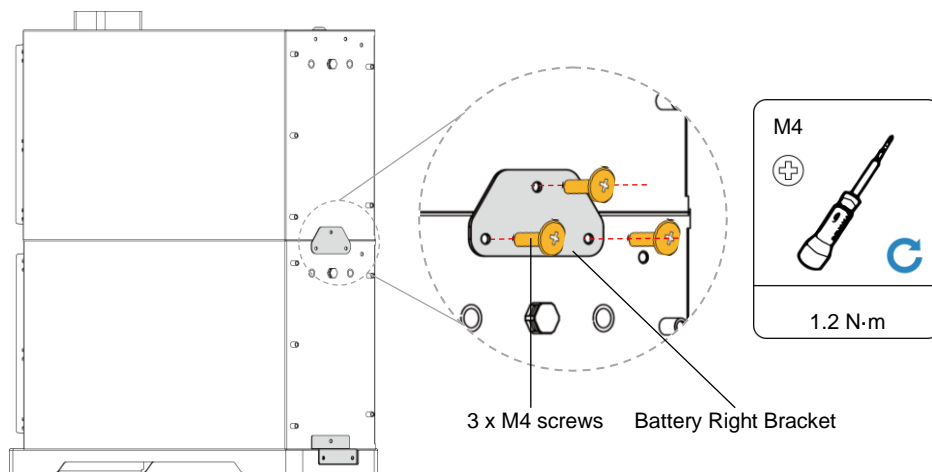

**Figure 5-18 Battery Installation on Battery Right Side Bracket**

D. A few steps with steps 2-E and 2-F to install the wall brackets of the second battery.

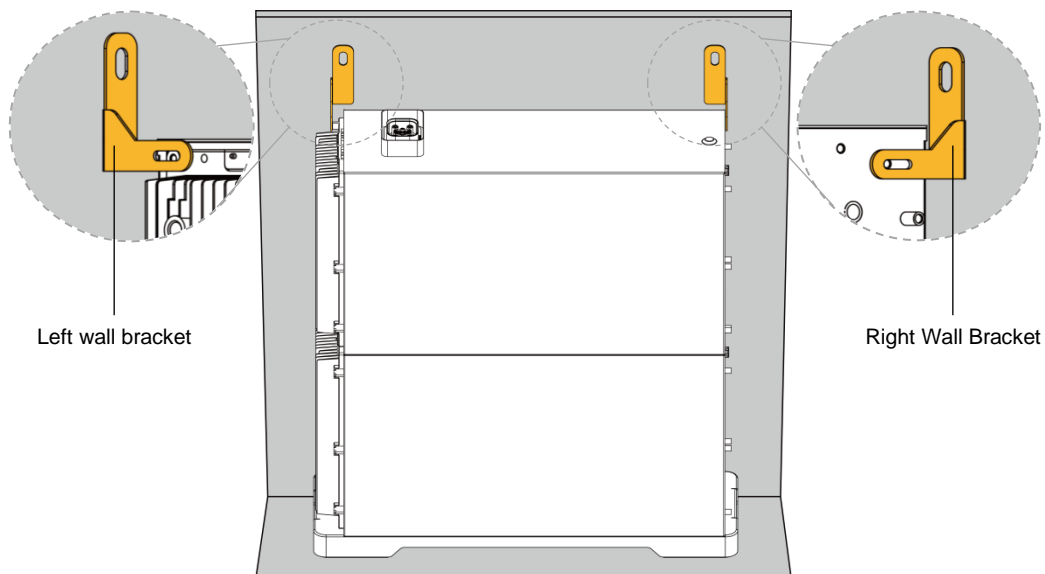

Figure 5-19 Install the Wall Bracket for the Second Battery

## ! ATTENTION!

### Instructions for attaching batteries and inverters

It is recommended that each battery be attached to the wall immediately after stacking it on the previous base or battery.

It is essential not to install all batteries and/or inverters without first having them properly anchored to the wall with the brackets provided, to avoid the risk of tipping over and falling.

Fixing procedure

#### 1. Installing the Side Brackets:

- Install the battery or inverter fixing brackets on the rest of them before lifting and stacking them
- Before attaching the battery or inverter to the wall, mount the side brackets that connect the unit to the adjacent unit.  
Do not attach the bracket to the wall first as it may move one or more modules of the system from the interlocking seat

#### 2. Wall mounting:

- After installing the side brackets, attach each battery or inverter to the wall using the supplied L-brackets.
- Make sure that the fastening is sturdy and secure, respecting the technical instructions provided in the manual.
- Apply the interlocking side covers, making sure to use the specific cover for each side

Follow this procedure for each battery or inverter before proceeding with the installation of the next unit.

### 4.3.4 Step 4. Install the inverter module.

A. Stack the inverter on top of the battery. Hold the side of the inverter--Lift the inverter--Align the inverter and battery--Place the inverter on top of the battery.

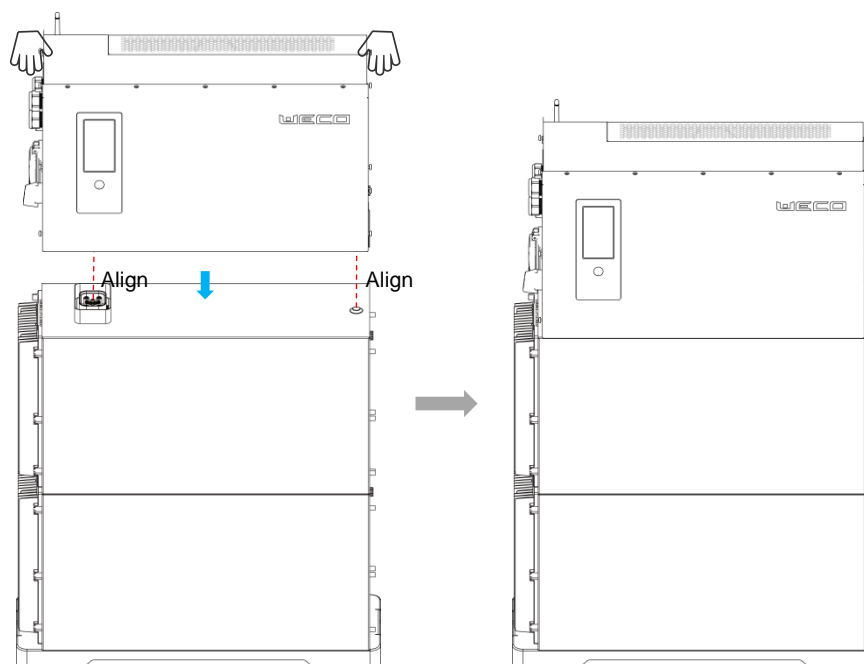

Figure 5-20 Inverter Module Installation

B. Take the brackets from the inverter package. Attach the left inverter bracket on the left side between the battery module and the inverter module.

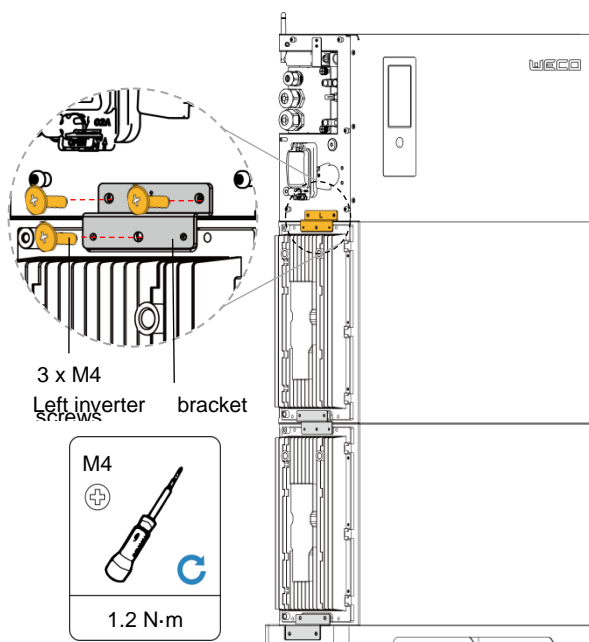
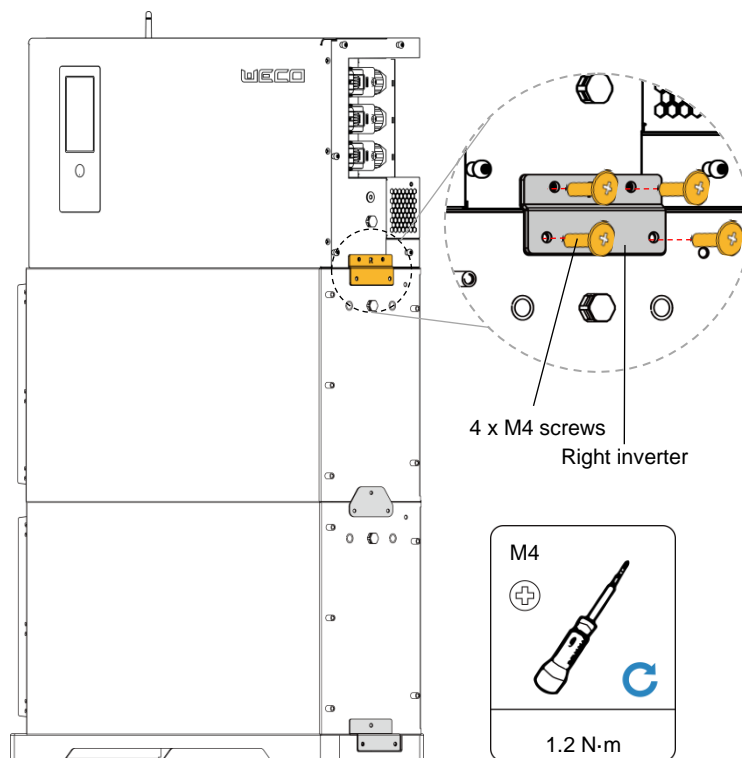

Figure 5-21 Install the Left Side Bracket of the Inverter

C. Attach the right inverter bracket on the right side between the battery module and the inverter module.



**Figure 5-22 Inverter Right Side Bracket Installation**

D. Take the wall brackets from the inverter package: Place the inverter wall brackets in the correct position, and then mark the holes for drilling.

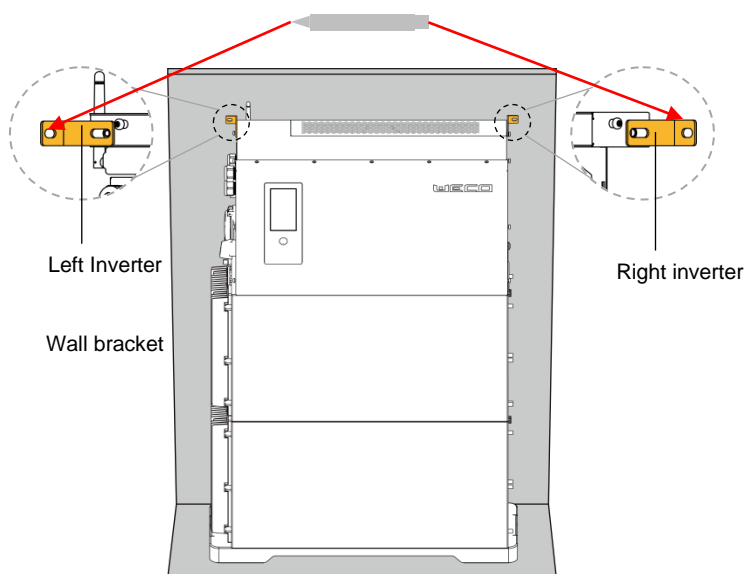

**Figure 5-23 Inverter Right Side Bracket Installation**

E. Drill the holes according to the marks--install the bolts--use the bolt nuts to fix the wall brackets--Fix the inverter to the wall.

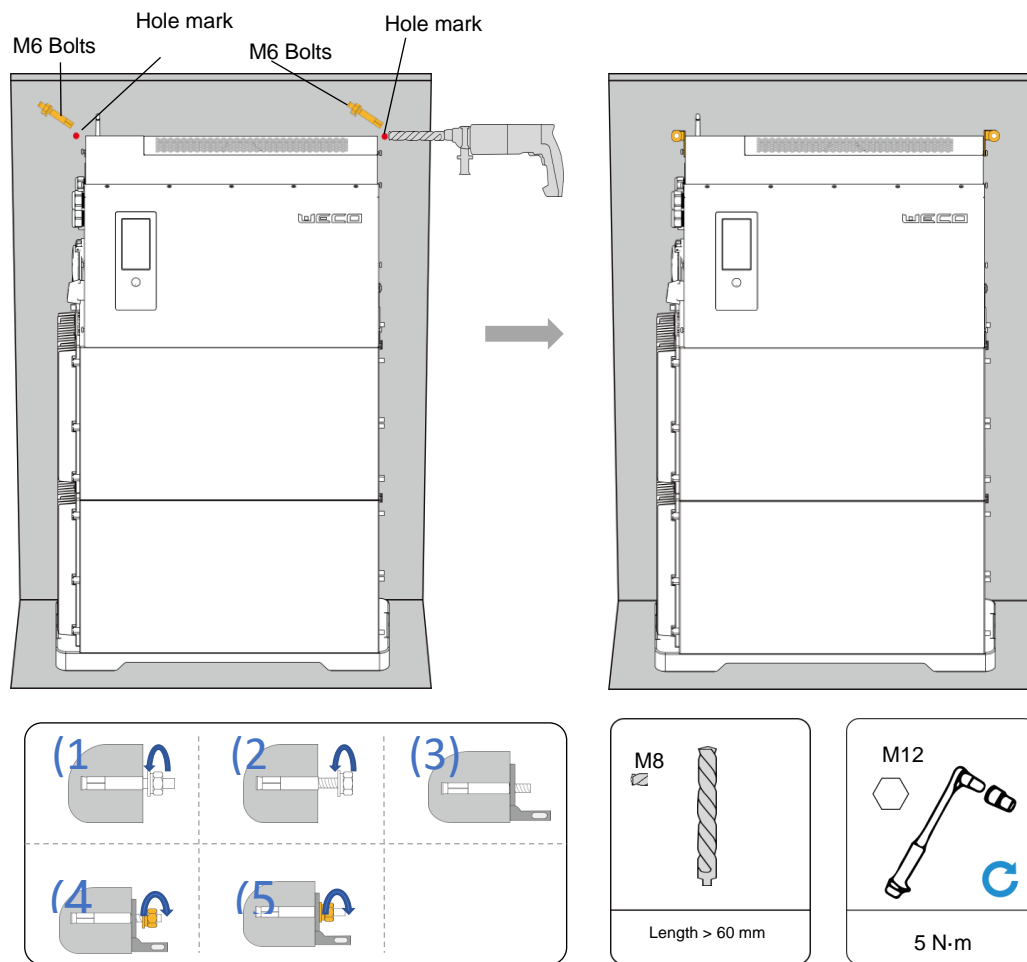

Figure 5-24 Inverter Right Side Bracket Installation

## 4.4 Electrical connection

### 4.4.1 System connection diagram

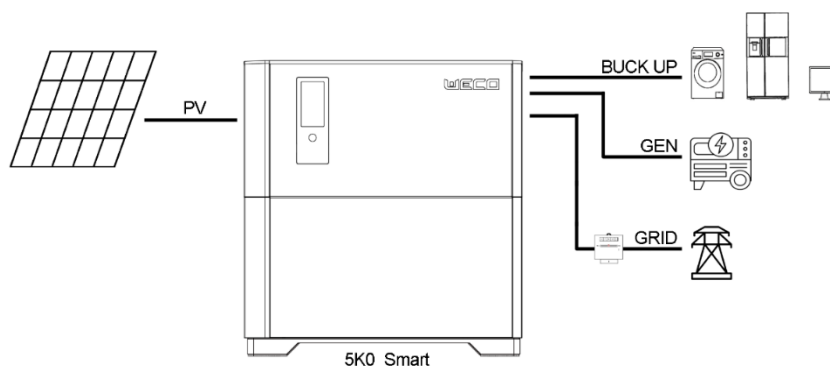

Figure 5-10 System Connection Diagram

### 4.4.2 Installing the DC Input Power Cables

Connect the Storage System to the PV string via the DC input line.

#### **⚠ DANGER**

- Sunlight generates direct current (DC) voltage and can lead to life-threatening situations. Therefore, when connecting the DC input cable in the presence of islands on the photovoltaic (PV) panels, it is crucial to insulate the string using fuses or cover the PV panels with a blackout sheet.
- Before proceeding with the connection of the DC input cable, it is essential to check that the Voc voltage is within the allowed values and that the DC circuit breaker of the Storage System is set to 'OFF'. Otherwise, the high voltage generated could be lethal.

#### **NOTICE**

- The output power of each PV string must not exceed the maximum input power of the Storage System and must remain below the maximum open-circuit voltage.
- Before assembling DC connectors, it is crucial to properly label the polarities of the cables to ensure a proper connection.
- The string current must not exceed the rating plate value allowed by the inverter and it is not allowed to connect two strings to the MPPT inputs in parallel.
- After crimping the positive and negative metal terminals, it is important to retract the DC input power cables to ensure that they are securely connected.
- Insert the crimped metal terminals of the positive and negative power cables into the appropriate connectors. After that, withdraw the DC input power cables again to ensure a solid connection.

## Procedure

- 1 Connect the DC input cable to the corresponding "BAT+" and "BAT-" terminals of the inverter.

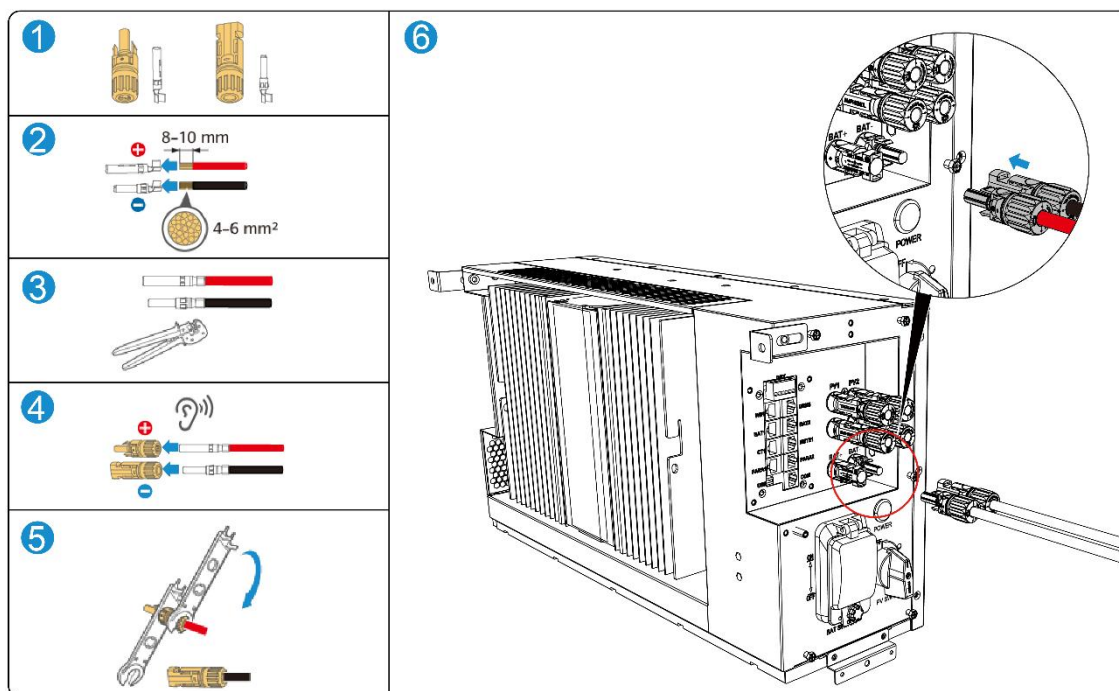

Figure 5-11 Installing the DC Input Power Cables

### 4.4.3 Installing the mains/load connection cable

#### NOTICE

- Make sure the Storage System is completely isolated from any DC or AC power source before connecting the AC cord.
- Please wire the machine strictly in phase sequence; Otherwise, the machine will not work properly.
- Connection to the grid requires an external AC switch to allow isolation from the mains if required.

## Procedure

- 1 Select the appropriate wire and strip the wire to the recommended size.

Table 5-1 Description of Stripping Dimensions

Diagram	No.	Article	Description
<b>Grid Connected Side (GRID/GEN Interface)</b>			
	A	Diameter	21~26mm
	B	Size	10 mm <sup>2</sup> or 6 AWG
	C	Length	11mm
<b>Load side (BACK UP interface)</b>			
	A	Diameter	10~14mm
	B	Size	6 mm <sup>2</sup> or 10 AWG
	C	Length	10mm

- 2 Insert the connected mains/load connector into the connection port of the Storage System and tighten the screws.

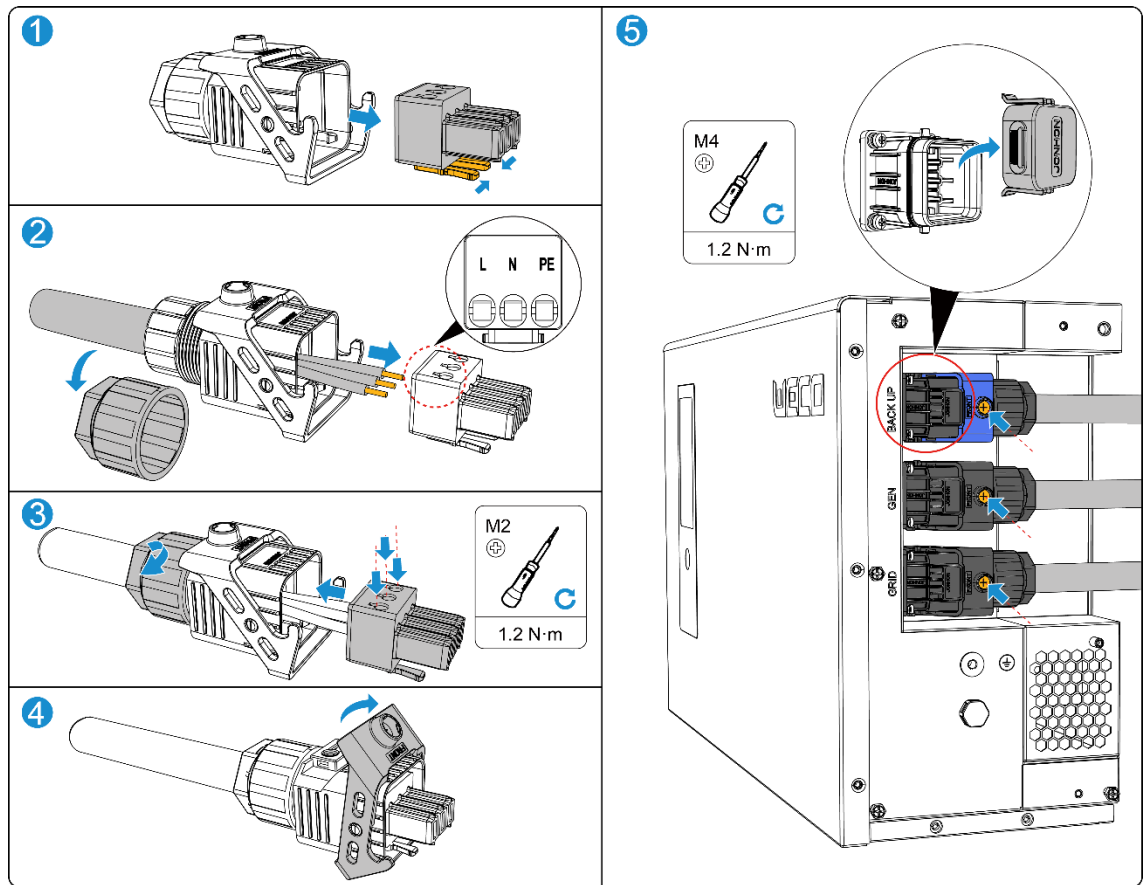

Figure 5-12 Installing the Cable Tie Connection/Network Load

#### 4.4.4 Communication Connection

##### 4.4.4.1 Definition of the communication port

Be sure to use a standard RJ45 cable and the plug is shown as follows.

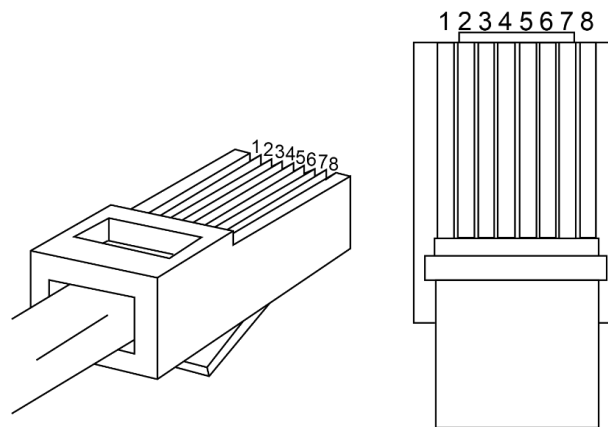

Figure 5-13 Defining Communication Interfaces

- The pin out of the WiFi /DRMS/METE1 ports is defined as follows.

Table 5-2 Pin Definitions for WiFi/DRMS/METE1 Ports

PIN	Wi-Fi connection	DRMS	TIME1
1	RS485_A4_Wifi/GPRS	DRM1/5	EXT-CT4_P
2	RS485_B4_Wifi/GPRS	DRM2/6	EXT-CT4_N
3	RS-232-TX	DRM3/7	RS485_A1_Mete1
4	GND_S	DRM4/8	RS485_A3_Mete2/NTC_CT+
5	GND_S	DRM_REF	RS485_B3_Mete2/NTC_CT-
6	RS-232-RX	DRM_COM	RS485_B1_Mete1
7	VCC_10V	VCC_10V	CT4_ON+
8	VCC_10V	GND_S	GND_S

- The pin out of the CT1/COMS/ PARA1/PARA2 ports is defined as follows.

Table 5-3 Pin Definitions for CT1/COMS/ PARA1/PARA2 Ports

PIN	CT1	COMS	PARA1/PARA2
1	EXT-CT1_P	RS485_A2_BAT	CANL1_PARAL1_EXT
2	EXT-CT1_N	RS485_B2_BAT	CANH1_PARAL1_EXT
3	EXT-CT2_P	GND_S	CANL2_PARAL2_EXT
4	EXT-CT3_P	CANH1_BAT	PAR_50HZ
5	EXT-CT3_N	CANL1_BAT	PAR_100HZ
6	EXT-CT2_N	WAKEUP_TOBAT	CANH2_PARAL2_EXT
7	CT1_ON+	DI1+	PAR_MASTER
8	GND_S	DI1-	GND_S

- The pin out of the BAT1/ BAT2/ DRY ports is defined as follows.

Table 5-4 Pin Definitions for BAT1/ BAT2/ DRY Ports

BROOCH	SOCK1	SOCK2	DRY	
1	CANH_Tower2	CANH_Tower3	NO1	Trunk node
2	CANL_Tower2	CANL_Tower3	NC1	OUT
3	24V_BUS+	24V_BUS+	NO2	Trunk node
4	100K_Tower2_Downer	100K_Tower3_Downer	NC2	OUT
5	Empty	Empty	DI2-	IN trunk node
6	24V_GND	24V_GND	DI2+	
7	StartON+	StartON+	/	/
8	StartON-	StartON-	/	/

### 4.4.4.2 Connecting the WiFi Module

#### NOTE

After installing and securing the WiFi module, it is crucial to take extra care when inserting the cables, making sure to connect the waterproof connector into the appropriate slot first.

#### Procedure

- 1 Attach the WiFi bracket to the WiFi module and then attach it to the inverter module.
- 2 Insert the WiFi cable with RJ45 plug through the cable connector into the "WiFi" port

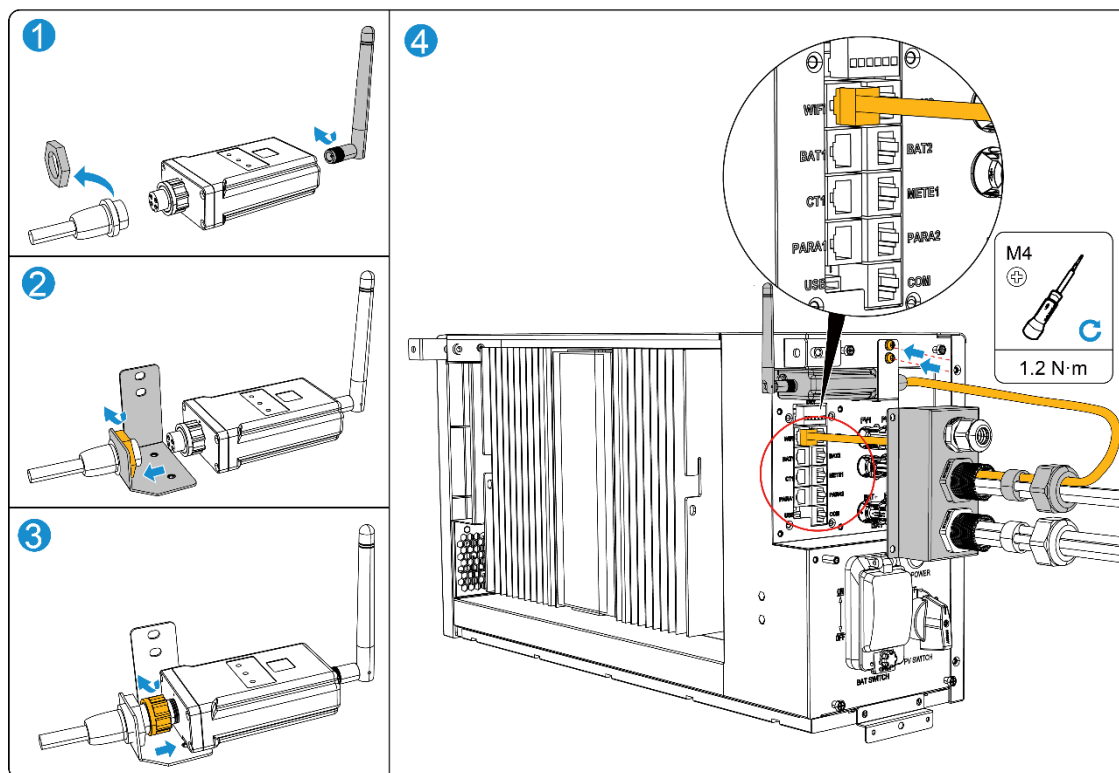

Figure 5-14 Connecting the WiFi Module

### 4.4.4.3 Connecting the Supplied Meter

The power meter detects the mains voltage, direction and current magnitude and further monitors the operating status of the storage system via RS485 communication.

The supplied Meter requires the insertion of the power cables into the L and N port of the Meter and the exit from the consequent L' N' port, no external CTs / Toroids are required as the current reading is taken directly from the internal sensors. Connecting the Meter requires the interruption of the power cable for the power supply of the domestic utility.

The maximum current supported by the Meter must not exceed 80Ampere 230Vac

The meter must then be connected via the RS485 communication port from the meter terminals to the METER port of the inverter with the PIN OUT as shown in the image below (see Meter manual for details). Pay attention to the connection point of the meter on the home system: The meter must be located upstream of the system, the inverter and all loads must be located below the meter.

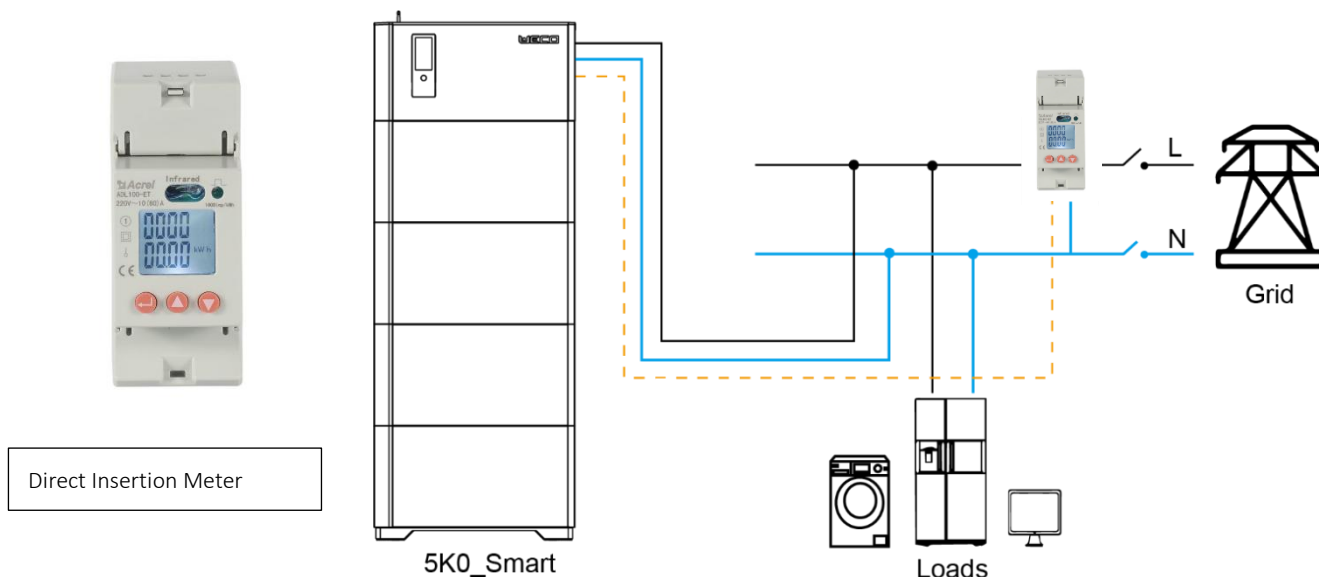

Figure 5-17 Direct Insertion Meter Connection Diagram

**Procedure**

- 1 Remove the tool from the accessory case.
- 2 Insert the meter cable with the RJ45 plug through the waterproof cable connector and into the "METE1" socket

Figure 5-16 CT Connection

Communication Cable	RS485A	RS485B
Late Mater	21	22
Lato Porta RJ45 Inverter	3	6

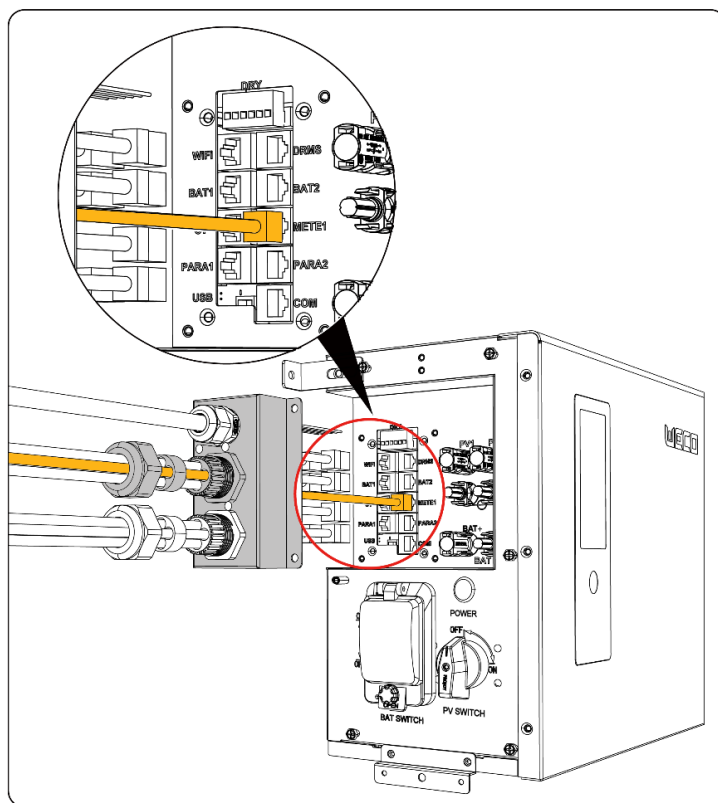

#### 4.4.4.4 Connecting the Meter with CT or CT only (non-standard accessory)

In addition to the direct insertion meter supplied in the standard kit, it is also possible to use a meter with CT or only the CT by following the following indications.

The meter is a device necessary for the installation of the system that is used to detect the direction and amplitude of the voltage and current of the electrical network and further monitor the operation of the storage system via RS485 communication.

#### CAUTION

- Make sure the Storage System is completely isolated from any DC or AC power source before connecting the AC cord.

#### NOTICE

- The signal cable must be threaded into the screw cap ro before being inserted into the sealing box.
- When the length of the CT cable cannot meet the usage requirements, the CT communication cable can be extended by an RJ45 connector.
- The direction of CT cannot be linked in reverse. Please follow the directions of K-L. Make sure the CT is connected between the load and the mains supply.
- It is recommended to install the CT inside the distribution box.

The CT connection diagram (only if you do not have the default meter provided by WeCo)

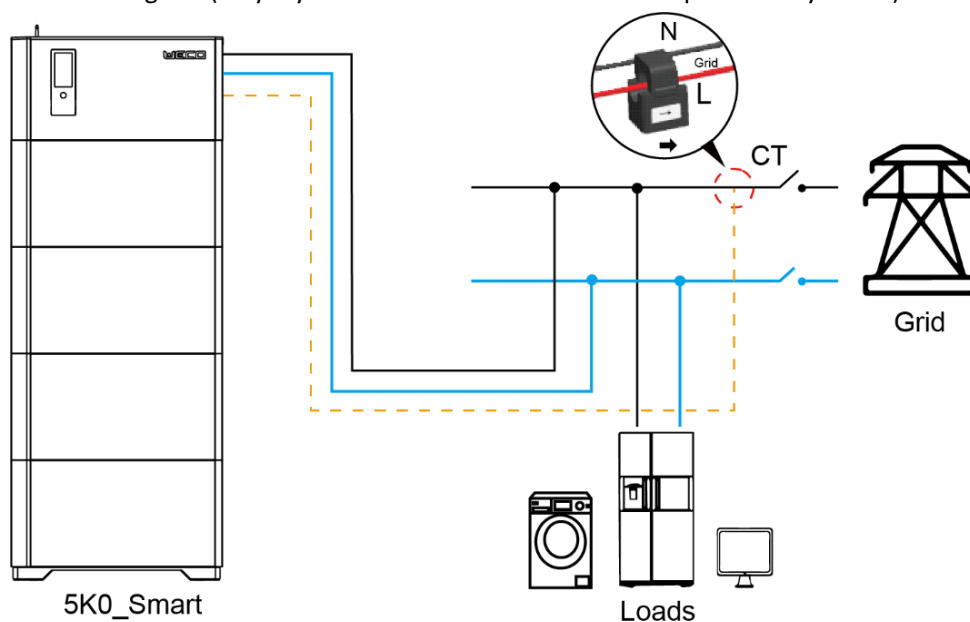

Figure 5-15 CT Connection Diagram

#### Direct CT connection procedure

- 1 Remove the CT with the cable from the accessory case.
- 2 Insert the CT cable with RJ45 plug through the waterproof cable connector into the "CT1" socket on the inverter side

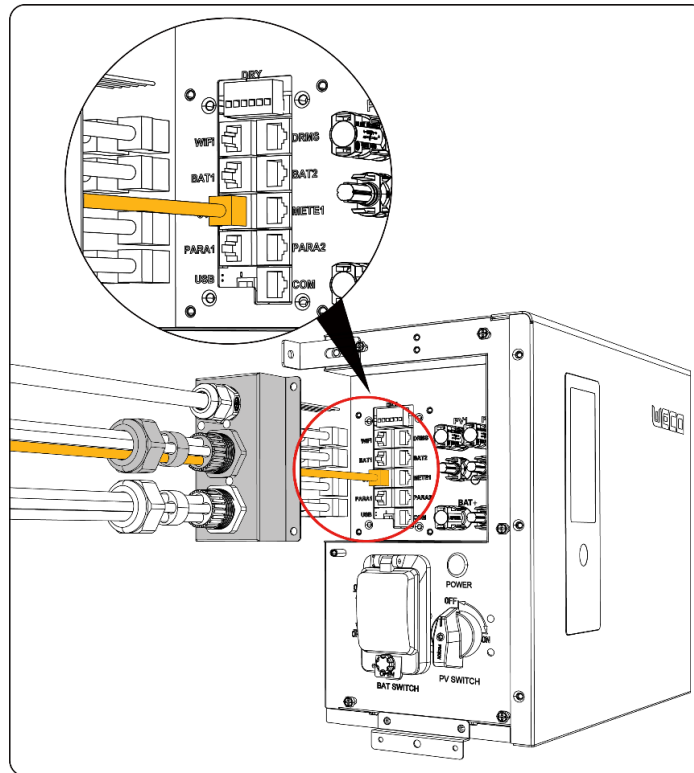

Figure 5-18 CT Connection

#### 4.4.4.5 Connecting the DRMS

The DRMS is only suitable for Australian and New Zealand installations and complies with Australian and New Zealand safety requirements.

##### Procedure

- 1 Prepare the communication cable.
- 2 Insert the DRMS cable with RJ45 plug through the waterproof cable connector and into the "DRMS" socket of the 5K0 Smart.

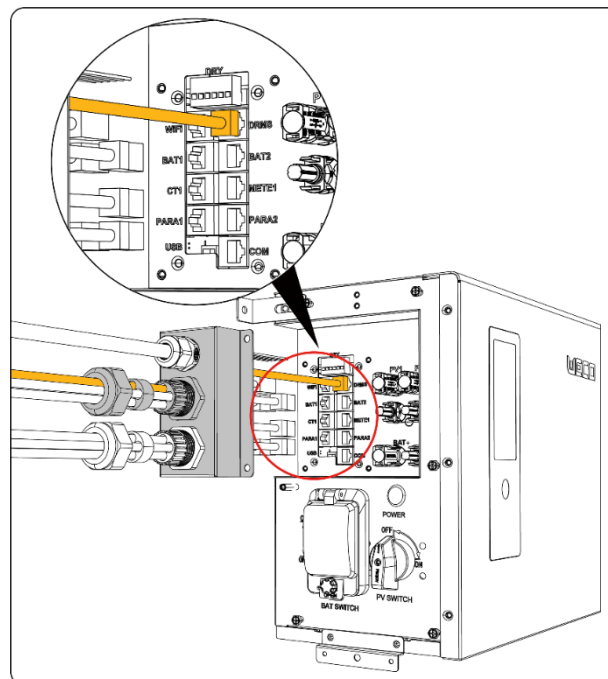

Figure 5-19 Connecting the DRMS

## 4.4.5 Installing a PE cable

The protective grounding cable must be connected during the installation of the equipment. For the ground connection, use the threaded bushing dedicated to the ground connection on the side of the Storage System, depending on the specific conditions of the site, opt for the connection from a single PE point or bring both the battery system and inverter to the ground from the dedicated PEs. It is also recommended to adopt the closest and verified grounding to ensure maximum safety and reliability.

### **⚠ DANGER**

Make sure that the PE cable is securely connected to the pole and to the structure of the storage system. Failure to do so may result in electric shock.

### NOTICE

- Avoid reducing the copper cross-section of the cable when stripping a cable.
- The cavity formed after the crimping strip of the crimped conductor of the OT terminal must completely wrap around the core wires. The core wires must come into close contact with the OT terminal.
- Wrap the wire crimp area with heat shrink tubing or electrical tape. Heat shrink tubing is used as an example.
- When using a heat gun, protect the equipment from scalding.

### Procedure

- 1 Crimp an OT terminal.

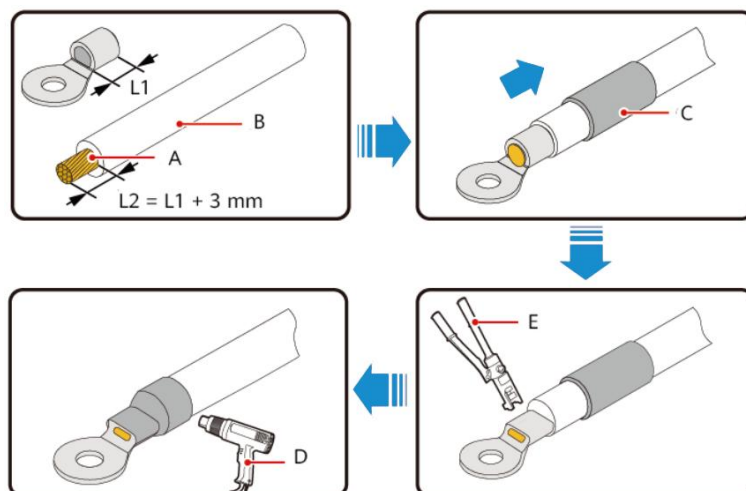

Figure 5-20 Crimp an OT Terminal

A: Lead wire	B: Insulation layer	C: Heat shrink tubing
D: Heat gun	E: Hydraulic Pliers	

- 2 Connect the ground point of the inverter module to the external ground point.

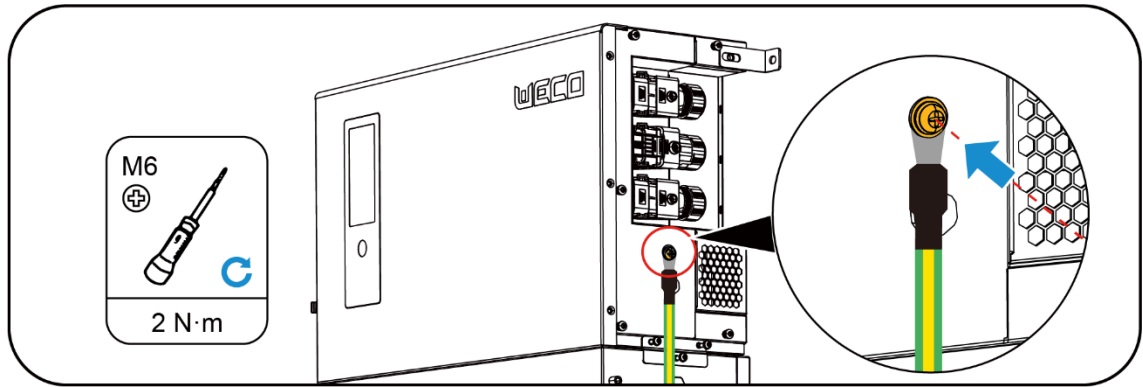

Figure 5-21 Grounding the PE Cable

## 4.5 Installing the Cover

When the electrical connections are complete, check that the cables are properly and securely connected, and install the outer protective cover.

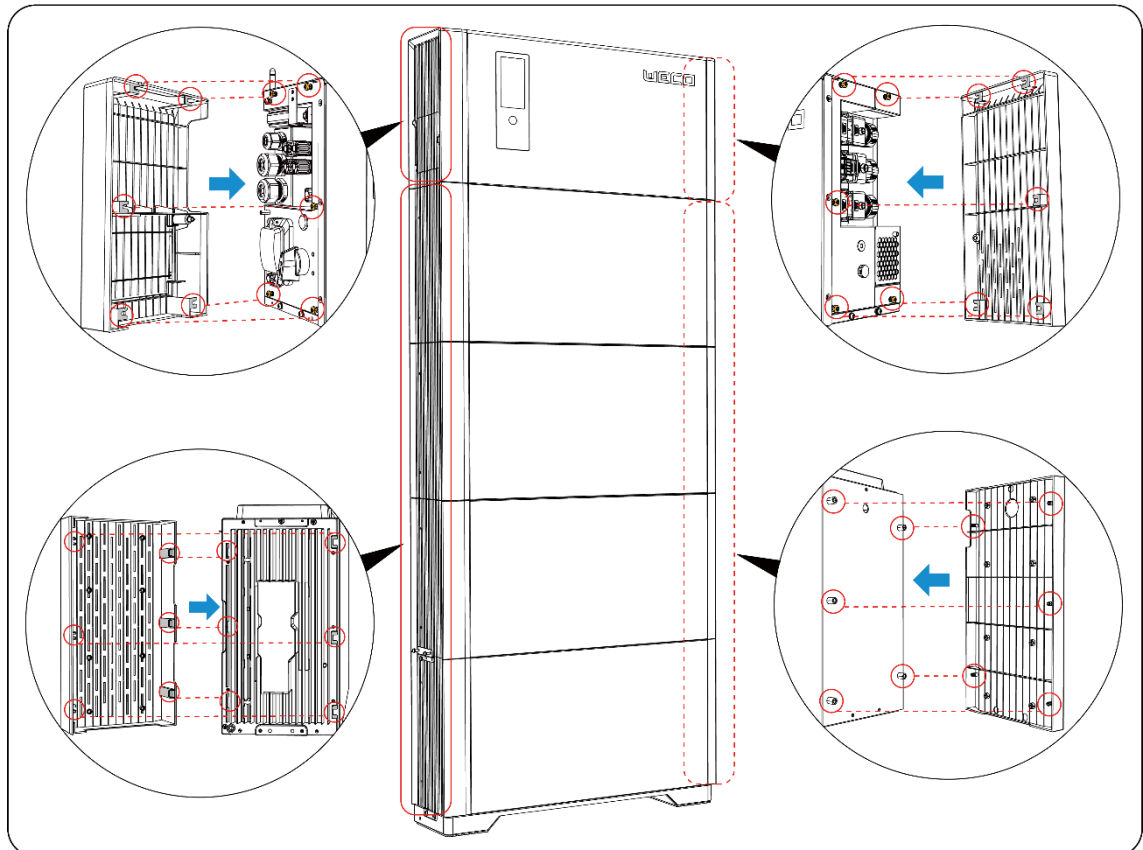

Figure 5-22 Installing the Cover

## 5 System commissioning

### 5.1 Starting the All-In-One

#### NOTICE

Before turning on the AC switch between the Storage System and the power grid, you need to set the multimeter to AC and check that the AC voltage is within the specified range.

#### Procedure

- 1 Place the DC switch "BAT SWITCH" on the inverter in the "ON" position.
- 2 Turn the "DC Switch" start switch on the inverter to the "ON" position.
- 3 Press the "POWER" button until the LED lights up.

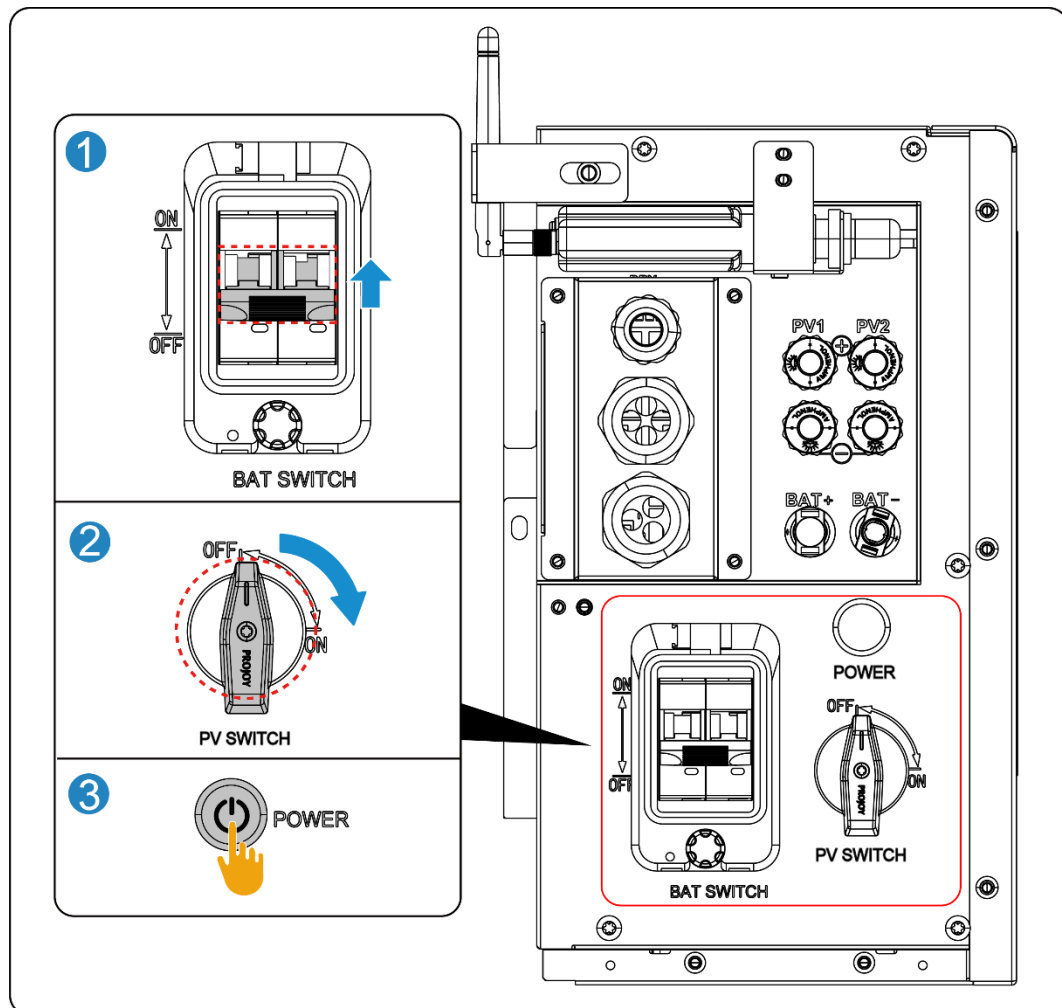

Figure 6-1 Starting the All-In-One

- 4 Observe the LED display and check the working status of the 5K0 Smart.

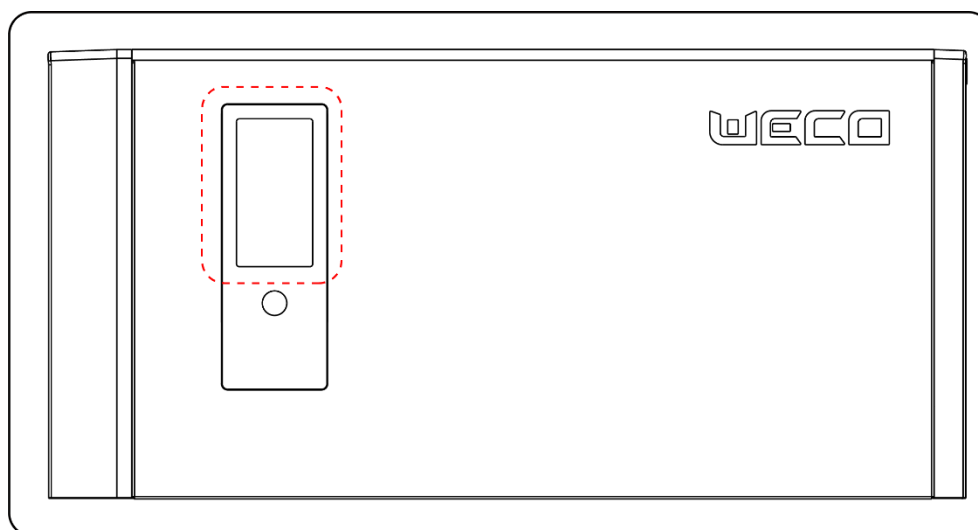

Figure 6-2 The Display Lights Up

## 5.2 Shutting down the system

### NOTICE

Do not disconnect the DC connector under load.

#### Procedure

- 1 Press the "POWER" button until the LED turns off.
- 2 Turn the "DC Switch" start switch on the inverter to the "OFF" position.
- 3 Place the DC switch "BAT SWITCH" on the inverter in the "OFF" position.

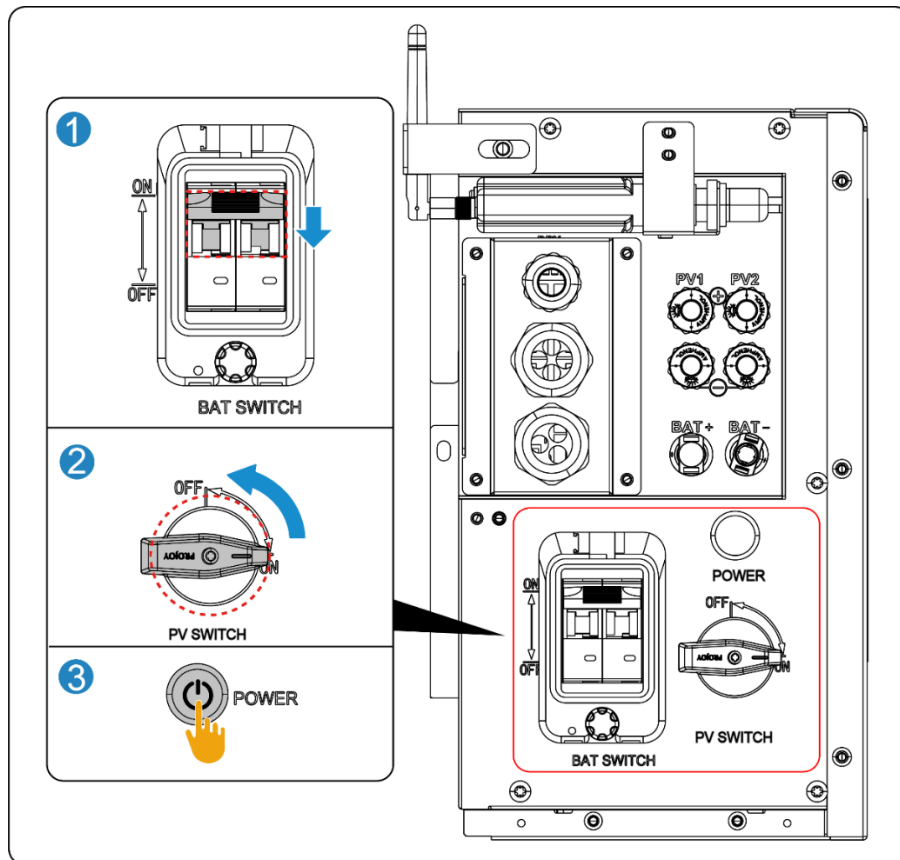

Figure 6-3 Turning Off System Power

- 4 Look at the LED display and check the operating status of the 5K0 Smart. Wait for the LCD to turn off and the Storage System to turn off.

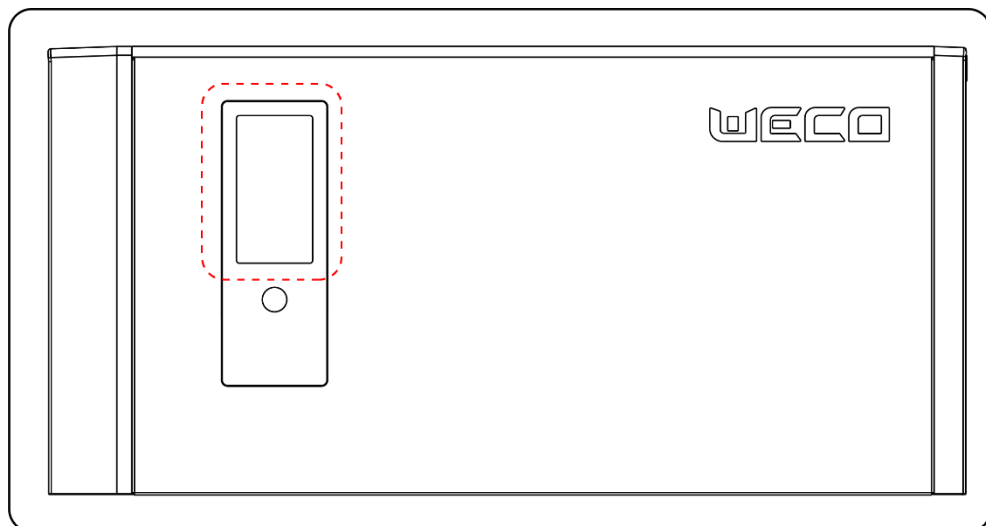

Figure 6-4 The Display Turns Off

## 6.1 System Interface

Under normal conditions, the display only shows the power flow and operating status of the device. All system settings must be managed using the supplied mobile app.

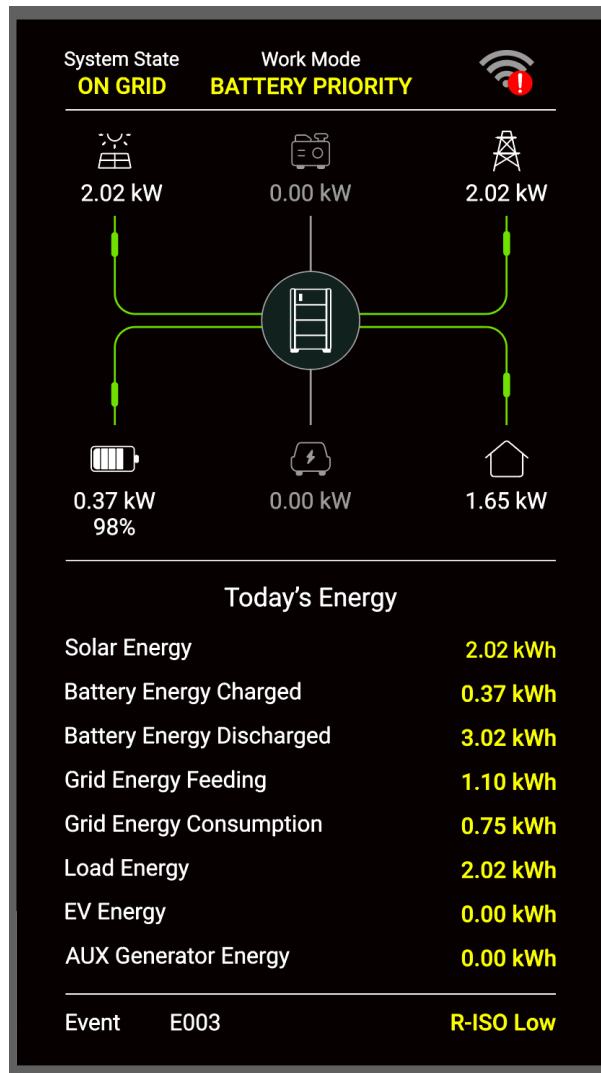
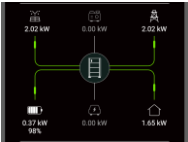

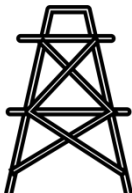



Figure 7-1 Display Interface

## 6.1.1 Standby interface

The standby interface contains four main menu screens, as shown in the following table.

**Table 7-1 Description of the Standby Interface**

Menu screen	Description
	<p>This screen displays the status of the system.</p> <ul style="list-style-type: none"> <li>● Energy: state of energy flow in all four directions</li> <li>● Dotted lines indicate power flow</li> </ul>
	<p>The icon displayed on this screen is the photovoltaic panel.</p> <ul style="list-style-type: none"> <li>● Icon: Always on when PV is connected, off when not connected.</li> <li>● Power flow: When the PV is charging, the green dotted line runs from the PV panel to the energy storage system; when there is no PV charging, the dotted line of the power flow is not displayed.</li> </ul>
	<p>The icon displayed on this screen is the power grid.</p> <ul style="list-style-type: none"> <li>● Icon: Always on when the network is connected, off when not connected.</li> <li>● Energy flow: at the time of discharge to the grid (energy sale), the green dotted line runs from the energy storage system to the grid; When drawing energy from the grid (purchasing), the red dotted line runs from the grid to the energy storage system; When you are not discharging into the grid or drawing power from the grid, the dashed line of the energy flow is not displayed.</li> </ul>
	<p>This screen shows the icon of the energy storage system.</p> <ul style="list-style-type: none"> <li>● Icon: Normally lit, displays the SOC value of the system.</li> </ul>
	<p>The icon displayed on this screen is the household load.</p> <ul style="list-style-type: none"> <li>● Icon: Always on when the home load switch is on, off when off.</li> <li>● Power flow: When discharging to the household load, the red dotted line flows from the energy storage system to the household load; When there is no discharge on the household load, the dashed line of the energy flow is not displayed.</li> </ul>



The icon displayed on this screen is of the EV charger

- Icon: Always on when the charging plug is connected to the vehicle, off when not connected.
- Energy flow: When charging is in progress, the red dotted line runs from the energy storage system.

## 6.1.2 Operation Information Menu

Table 7-2 Today's energy data from the LCD display

NO.	Name	Description
1	Panel power	PV energy, the progress bar is green, and the PV power is indicated in real time.
2	Mains power supply	For grid power, the progress bar is green when discharging into the grid (energy sales) and red when drawing energy from the grid (energy sales). The length of the progress bar is displayed according to the proportion of the power to the full scale value, and the color depth increases from left to right. The number on the right side is also green (red when you take power) and is the current discharge power (power outlet) in real time.
3	Consumption	Accumulated energy consumption per day, automatically deleted at 23:59 each day. The color of the progress bar is blue, and the color depth increases as the value increases; When the power consumption exceeds the nominal range, the progress bar is incremented to red. The number on the right side is the cumulative energy consumption kwh; The color is blue when it is below the nominal range and red when it is greater than or equal to the nominal range.
4	Self-sufficiency	PV production as a percentage of total electricity consumption (tram charging plus household load consumption).
5	Event	Error and warning codes.
6	ERROR	The fault alarm icon has a white triangular background and a red exclamation mark; the red exclamation mark flashes once every 1 second to be displayed when a fault occurs, and the Corresponding Event column shows the corresponding error code.
7	CAUTION	In the critical alert indicator, the yellow icon is displayed in case of malfunction, and the Corresponding Event column shows the corresponding alert code.
8	BLUETOOTH	The Bluetooth connection logo will be blue when the connection is successful.
9	Wi-Fi connection	WiFi signal connection logo, blue color when the connection is successful; flashing icon during pairing.

## 6.2 System Configuration

### 6.2.1 Download dell'app

#### Download from the App Store

- iPhone users: Search for "Noor BT" in the App Store.
- Android users: Search for "Noor BT" on Google Play.

#### User access

After completing the download and installation, open the app, enter your password, and click "Sign In."

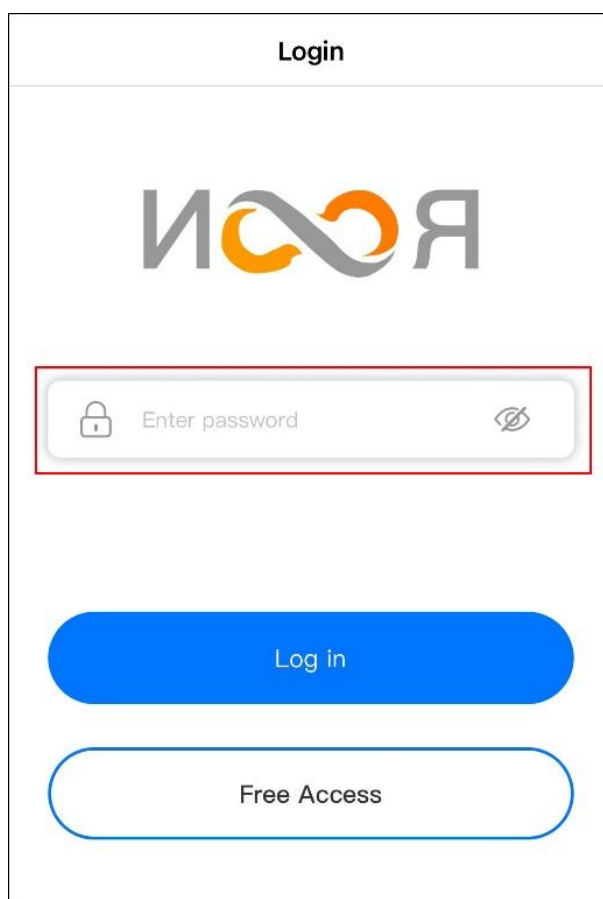

Figure 7-3 User Access

---

#### NOTE

The app needs to get the corresponding permissions for the phone, and then accepts all the requested permissions.

---

## 6.2.2 Connecting the WiFi Module

### Procedure

- 1 After logging in to the app, the scanning interface will be displayed, and the QR code of the WiFi module will be scanned or recognized for access by selecting it from the photo album to enter the device information interface.

If the QR code is damaged or scanned abnormally, you can tap the " " icon  to manually enter the numbers under the QR code.

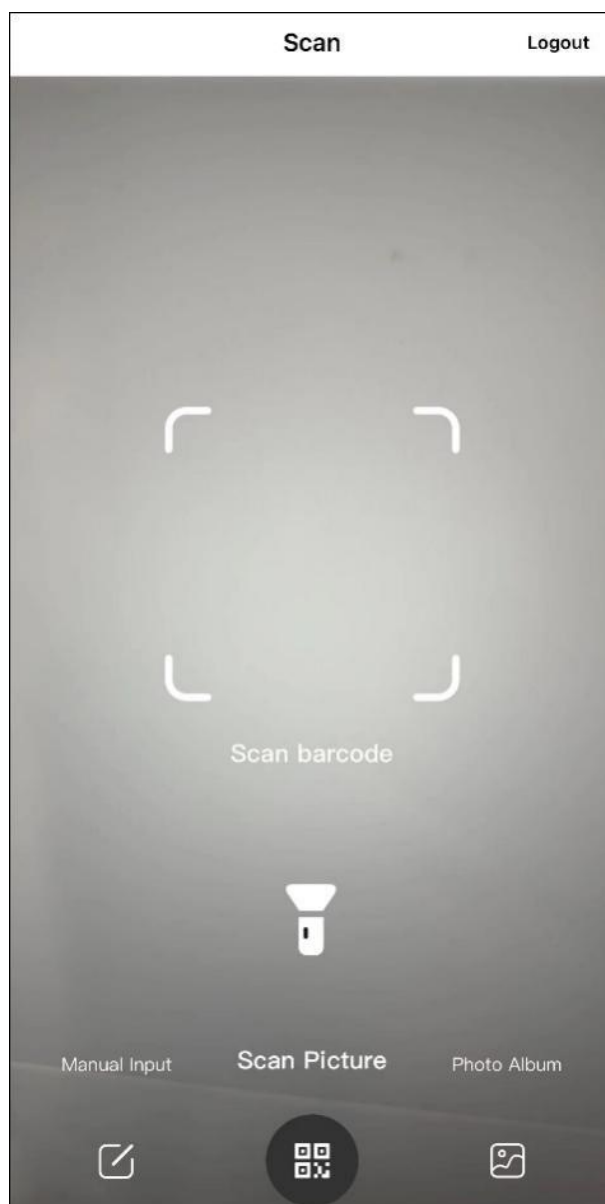

**Figure 7-4 Scanning the QR code of the WiFi module**

- 2** Enter the device information interface, click "Setup" on the right side of Wi-Fi networks, enter the account password, connect to WiFi, and click "Send Data".

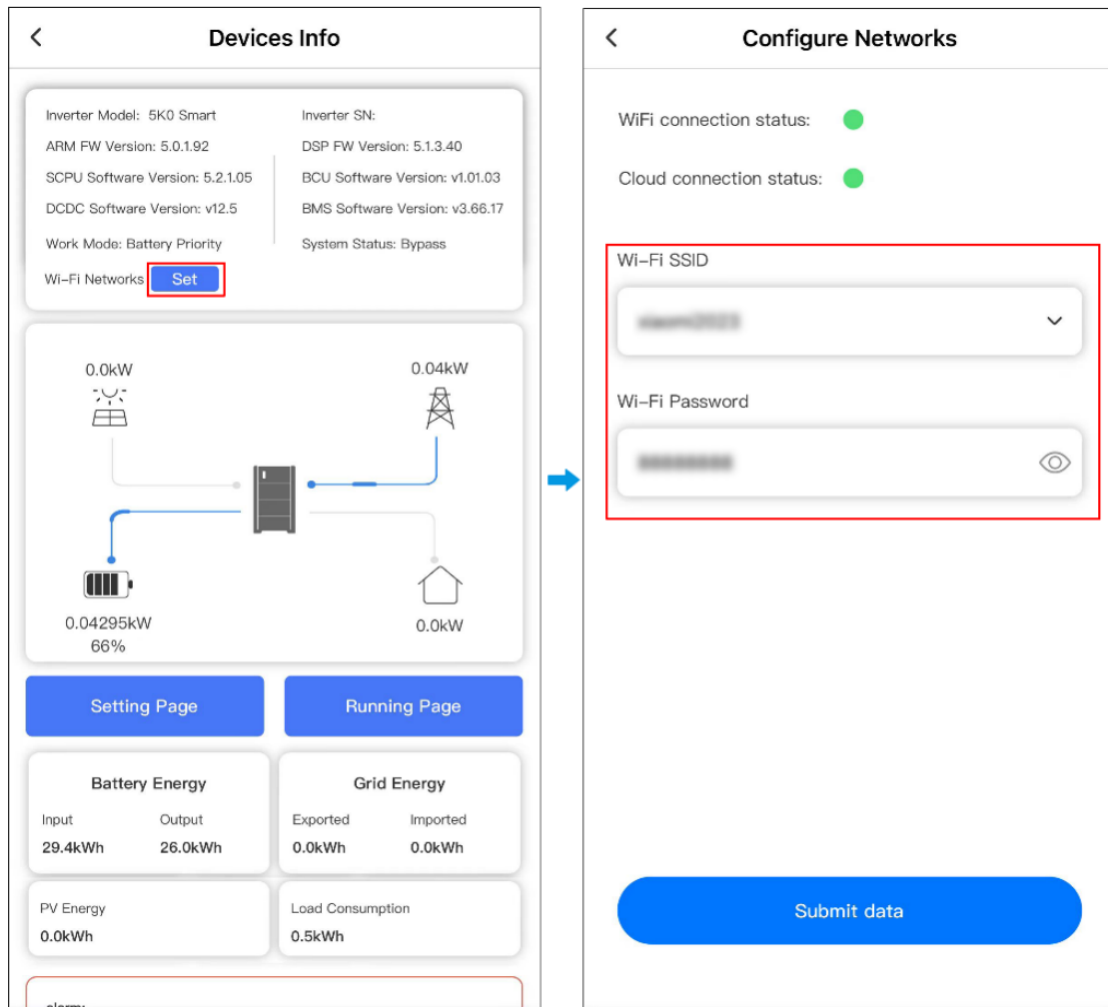

Figure 7-5 Device Information Screen

## 6.2.3 Data visualization

By entering the device information interface of the app, you can view basic device information, device operation mode, device input/output energy data, and other information. Click "Running Page" to enter the running information interface, and swipe left to view the real-time operation details of the inverter, grid, load, PV, and battery.

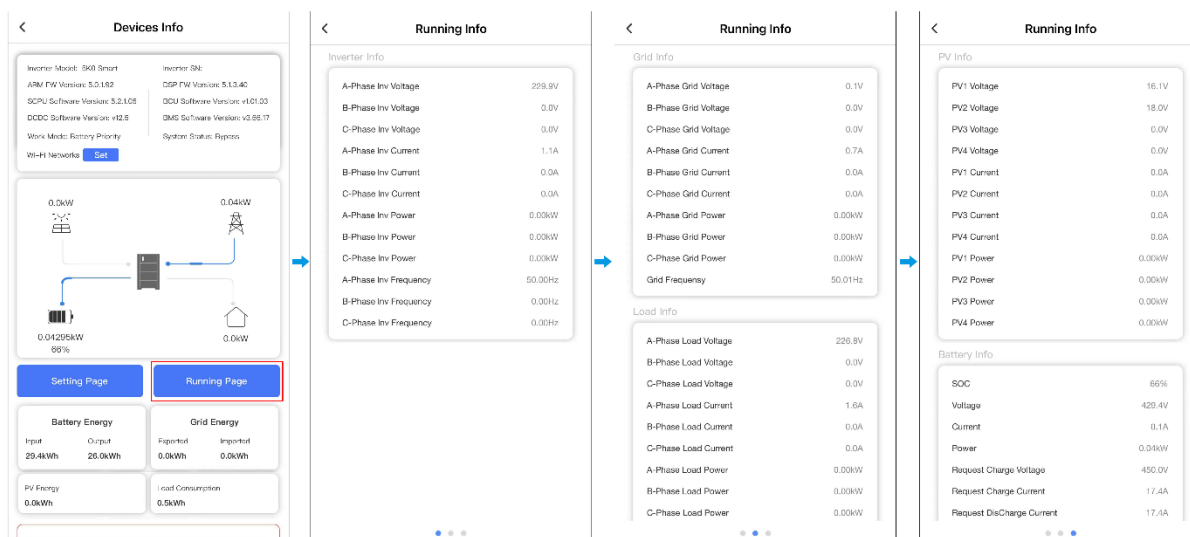

Figure 7-6 Real-Time Ride Information

## 6.2.4 Parameter Settings

Enter the device information interface of the app and click "Settings Page" to enter the primary settings interface; According to the instructions on the page, you can set the date and time, operation mode, inverter settings, and battery settings, and swipe left to turn the page, which can also set other parameters.

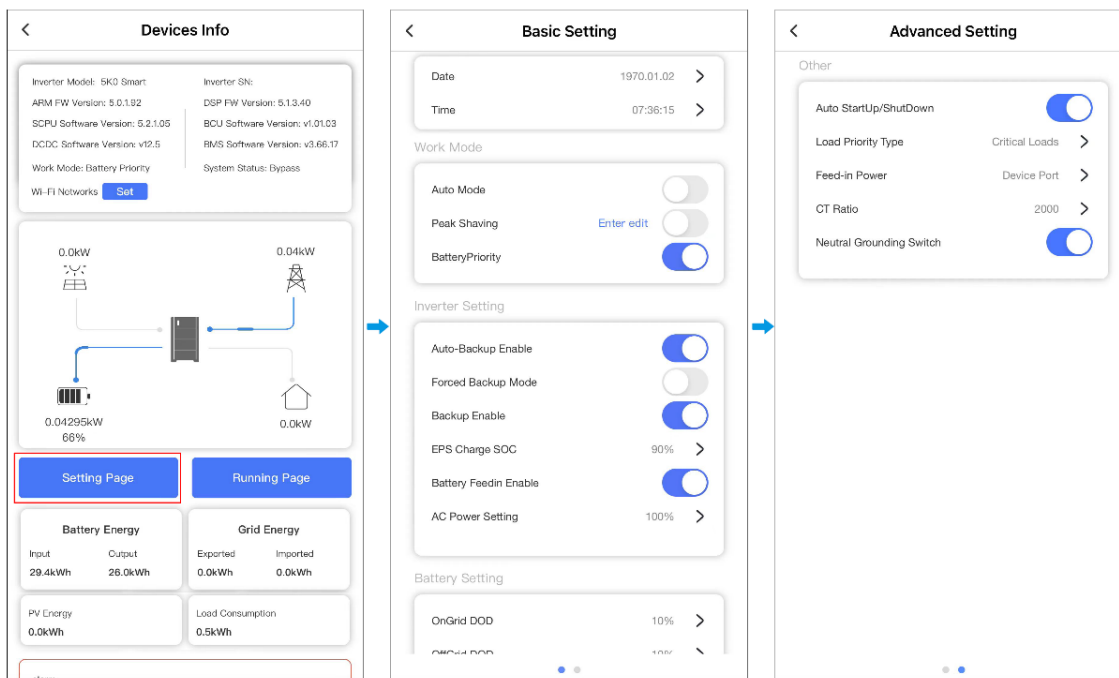

Figure 7-7 Parameter Settings

### 6.3 Working Mode

The working mode of the system is classified into three: automatic mode, peak shaving and battery priority, and the system can be set by the following operations via the display.

#### 6.3.1 Auto Mode

In this mode, the energy generated by the PV first satisfies the local load, then charges the battery, and the excess energy is fed into the grid; when the photovoltaic energy is insufficient, the photovoltaic and the battery jointly discharge the load; When the sum of battery power and PV is not enough to operate the load, the insufficient power is supplied by the grid.

Table 7-3 Auto Mode

NO.	Diagram	Description
<b>Mains, PV, battery available</b>		
1		<p><b>PV Power &gt; Load Power</b></p> <ul style="list-style-type: none"> <li>● If the PV power exceeds the load power, the excess power charges the battery.</li> <li>● If the PV power is greater than the load power plus the battery power, the excess power is fed back into the grid when power sales are enabled, and PV limits the power output when power sales are disabled.</li> </ul>
2		<b>Photovoltaic power &lt; Load power</b>

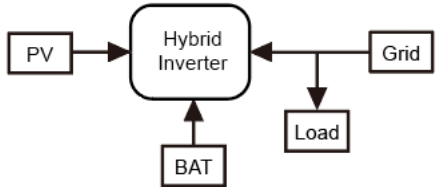
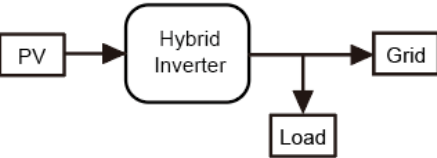
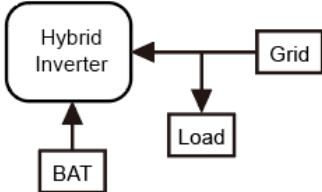
NO.	Diagram	Description
		<ul style="list-style-type: none"> <li>● If the PV power plus the battery power exceeds the load power, the PV feeds the load and the battery integrates the deficiency.</li> <li>● If the PV power plus the battery power is less than the load power, the PV and battery feed the load and the deficiency is supplemented by the grid.</li> </ul>
<b>Grid, PV available, battery not available</b>		
3		<ul style="list-style-type: none"> <li>● If the PV power is lower than the load power, the PV provides power to the load, and the grid integrates the shortage.</li> <li>● If the PV power is greater than the load power, the PV provides power to the load, and the excess energy is fed back into the grid when power sales are enabled, and PV limits the power output when power sales are disabled.</li> </ul>
<b>Grid, PV not available, battery available</b>		
4		<ul style="list-style-type: none"> <li>● The power of the battery is greater than the power of the load, which is powered by the battery.</li> <li>● The battery power is lower than the load power, so the load is powered by the battery, and the grid integrates the shortage.</li> </ul>

### 6.3.2 Peak Shaving

In this mode, in the set charging period, the energy generated by the photovoltaic system is prioritized to meet the battery charge, the excess is supplied to the load and, if there is still energy left, it is fed back into the grid; When the PV energy does not reach the maximum charging power, the grid provides the excess energy to charge the battery, and the grid also provides the load.

Users can realize it through the three parts of parameter setting, charging setting, and discharging setting. The charging and discharging time settings must not overlap and the time must be within 24 hours.

Table 7-4 Flush Shaving

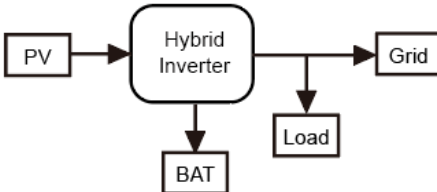
NO.	Diagram	Description
<b>Accusation</b>		
1		<p><b>Photovoltaic energy &gt; Battery power</b></p> <ul style="list-style-type: none"> <li>● If the PV power is greater than the load power plus the battery power, the PV charges the battery and supplies power to the load. Excess energy is fed back into the grid when it is enabled to sell energy, and photovoltaics limit the power output if it is disabled.</li> <li>● If the PV power is less than the load power plus the battery power, the PV charges the battery, and the excess provides power to the load.</li> </ul>

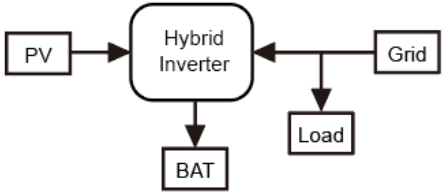
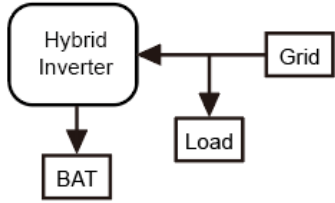
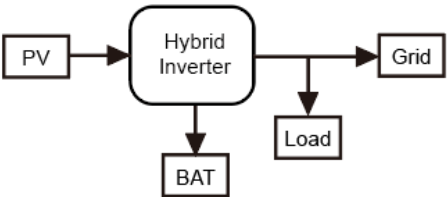
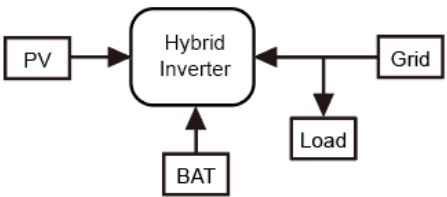
NO.	Diagram	Description
2		<p><b>Photovoltaic energy &lt; Battery power</b></p> <ul style="list-style-type: none"> <li>● The SOC of the battery is lower than the set target SOC, PV, and mains charge of the battery.</li> <li>● If the battery SOC exceeds the set target SOC, only the PV charges the battery.</li> </ul>
3		<p><b>Grid, PV not available, battery available</b></p> <p>Mains power supply to charge the battery.</p>
<b>Discharge</b>		
4		<p><b>PV Power &gt; Load Power</b></p> <ul style="list-style-type: none"> <li>● If the PV power is more significant than the load power, the excess power charges the battery.</li> <li>● If the PV power is greater than the load power plus the battery power, the excess power is fed back into the grid when power sales are enabled, and PV limits the power output when power sales are disabled.</li> </ul>
5		<p><b>Photovoltaic power &lt; Load power</b></p> <ul style="list-style-type: none"> <li>● If the PV power plus the battery power is greater than the load power, the PV powers the load and the battery integrates the deficiency.</li> <li>● If the PV power plus the battery power is less than the load power, the PV and battery feed the load and the grid makes up for the shortage.</li> </ul>

### 6.3.3 Battery priority

In this mode, when there is a power grid, the energy generated by the PV is prioritized to meet the battery charge. If the photovoltaic energy is insufficient, it will be supplied by the electricity grid. When the power grid is disconnected, the system immediately switches to off-grid mode to supply power to the load; When the power grid is restored, the system operation mode switches to grid connection mode to prioritize battery charging.

Table 7-5 Battery Priority

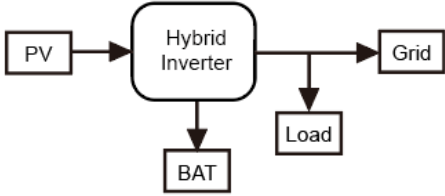
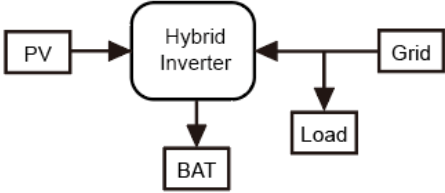
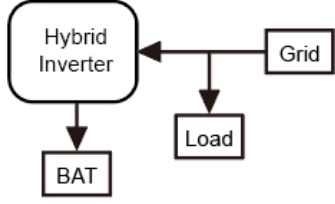
NO.	Diagram	Description
<b>Mains, PV, battery available</b>		
1	 <pre> graph LR     PV[PV] --&gt; HI[Hybrid Inverter]     HI --&gt; Grid[Grid]     HI --&gt; Load[Load]     HI --&gt; BAT[BAT] </pre>	<p><b>Photovoltaic energy &gt; Battery power</b></p> <ul style="list-style-type: none"> <li>● If the PV power exceeds the load and power of the battery, the PV charges the battery to power the load. Excess energy is fed back into the grid when energy sales are enabled, and photovoltaics limit the power output if it is disabled.</li> <li>● If the PV power is less than the load power plus the battery power, the PV charges the battery, and the excess provides power to the load.</li> </ul>
2	 <pre> graph LR     PV[PV] --&gt; HI[Hybrid Inverter]     Grid[Grid] --&gt; HI     HI --&gt; Load[Load]     HI --&gt; BAT[BAT] </pre>	<p><b>Photovoltaic energy &lt; Battery power</b></p> <ul style="list-style-type: none"> <li>● The SOC of the battery is lower than the set target SOC, PV, and mains charge of the battery.</li> <li>● If the battery SOC exceeds the set target SOC, only the PV charges the battery.</li> </ul>
<b>Grid, PV not available, battery available</b>		
3	 <pre> graph LR     Grid[Grid] --&gt; HI[Hybrid Inverter]     HI --&gt; Load[Load]     HI --&gt; BAT[BAT] </pre>	Mains power supply to charge the battery.

## 7 Maintenance

### 7.1 Route maintenance

Table 8-1 Routine Maintenance

Article	Inspection criteria	Abnormal handling
Heat dissipation	Gently wipe the surface of the cabinet with white paper without visible discoloration.	If this product periodically reduces the output power due to high temperatures, check the environment around the product for moisture and dust, and clean the product if necessary.
DC Switch	Periodically inspect DC circuit breakers and cables for externally visible damage and discoloration.	Contact the installer if there is any visible damage to the DC breaker, discoloration, or cord.
Cleaning	Gently wipe the surface of the cabinet with white paper with no visible darkening.	Dirt on the surfaces, turn off the AC circuit breaker and DC circuit breaker, wait for this product to turn off, and then wipe it with a cloth or compressed air. Do not use cleaning agents (such as solvents or abrasives).

### 7.2 Troubleshooting

Our quality control program ensures that every Storage System is built to specification and thoroughly tested before leaving the factory. If standard fault alarms and troubleshooting methods are used, as shown in the table below.

Table 8-2 Troubleshooting

Error code	Alarm Name	Opinion
F001	Inverter failure	1. Restart the 5K0 Smart. 2. If restarting does not resolve the issue, contact the manufacturer.
F002	Caveau relè inverter	1. Restart the 5K0 Smart. 2. If restarting does not resolve the issue, contact the manufacturer.
F003	Inverter overload alarm	1. Reduce the output load.
F004	Inverter overload fault	1. Reduce the output load. 2. Restart 5K0 Smart.
F005	Meter/CT fault	1. Check that the meter complies with the 5K0 Smart protocol. 2. Check that the wiring is correct between the tool and 5K0 Smart. 3. Check that the CT wiring and Storage System are good.
F006	Error communicating with WiFi	1. Check if the WiFi module complies with the 5K0 Smart protocol. 2. Check if the wiring between the WiFi module and the Storage System is good.
F007	Inverter overtemperature	1. Check if the temperature is within specifications. 2. Restart 5K0 Smart.
F008	Leakage current failure	1. Check that the leakage current sensor is installed correctly. 2. Check whether the PE cable is well connected.

Error code	Alarm Name	Opinion
F009	Arc fault	1. Check if the arc pull sensor is installed correctly.
F010	Leakage Current Sensor Failure	1. Check that the leakage current sensor is installed correctly. 2. Check whether the leakage current sensor connection cable is insufficient contact or disconnected.
F011	Arc Absorption Sensor Failure	1. Check if the arc pull sensor is commonly installed. 2. Detect if the arc pull sensor connection cable is in bad contact or disconnected.
F012	Reverse connection of the external sensor	1. Detect if the outdoor sensor is inverted.
F013	Low PV insulation impedance	1. Check that the connection between the photovoltaic panel and the storage system is good. 2. Check if the PE of the Storage System is good.
F014	PV1 Fault	1. Check that the PV parameters are within the specifications and restart the 5K0 Smart. 2. If restarting does not resolve the issue, contact the manufacturer.
F015	PV1 Reverse Connection	1. Check whether the positive and negative wires of the PV panel appear to be reversed.
F016	PV2 Fault	1. Check that the PV parameters are within the specifications and restart 5K0 Smart. 2. If restarting does not resolve the issue, contact the manufacturer.
F017	PV2 Reverse Connection	1. Check whether the positive and negative wires of the PV panel appear to be reversed.
F018	PV3 Fault	1. Check that the PV parameters are within the specifications and restart 5K0 Smart. 2. If restarting does not resolve the issue, contact the manufacturer.
F019	PV3 Reverse Connection	1. Check whether the positive and negative wires of the PV panel appear to be reversed.
F020	PV4 Fault	1. Check that the PV parameters are within the specifications and restart 5K0 Smart. 2. If restarting does not resolve the issue, contact the manufacturer.
F021	PV4 Reverse Connection	1. Check whether the positive and negative wires of the PV panel appear to be reversed.
F022	DC Fault	1. Restart the 5K0 Smart. 2. If restarting does not resolve the issue, contact the manufacturer.
F023	Inverter output short circuit	1. Check for a short circuit in the backup load. 2. Check the output of the Storage System in Off-Grid mode for a short circuit.
F024	Network Failure	1. Check that the grid parameters are within the regulated standard voltage range. 2. Check that the network connection is good. 3. Check that the switch on the cable is open. 4. Restart the 5K0 Smart. 5. If restarting does not resolve the issue, contact the manufacturer.

<b>Error code</b>	<b>Alarm Name</b>	<b>Opinion</b>
F025	Generator failure	<ol style="list-style-type: none"> <li>1. Verify that the generator parameters are within the regulated standard voltage range.</li> <li>2. Check that the network connection is good.</li> <li>3. Check that the switch on the cable is open.</li> <li>4. Restart the 5K0 Smart.</li> <li>5. If restarting does not resolve the issue, contact the manufacturer.</li> </ol>
F049	Slave Error 1	<ol style="list-style-type: none"> <li>1. Restart the 5K0 Smart.</li> <li>2. If restarting does not resolve the issue, contact the manufacturer.</li> </ol>
F050	Slave Failure 2	<ol style="list-style-type: none"> <li>1. Restart the 5K0 Smart.</li> <li>2. If restarting does not resolve the issue, contact the manufacturer.</li> </ol>
F051	Slave Failure 3	<ol style="list-style-type: none"> <li>1. Restart the 5K0 Smart.</li> <li>2. If restarting does not resolve the issue, contact the manufacturer.</li> </ol>
F052	Slave Error 4	<ol style="list-style-type: none"> <li>1. Restart the 5K0 Smart.</li> <li>2. If restarting does not resolve the issue, contact the manufacturer.</li> </ol>
F053	Slave Failure 5	<ol style="list-style-type: none"> <li>1. Restart the 5K0 Smart.</li> <li>2. If restarting does not resolve the issue, contact the manufacturer.</li> </ol>
F054	Slave Failure 6	<ol style="list-style-type: none"> <li>1. Restart the 5K0 Smart.</li> <li>2. If restarting does not resolve the issue, contact the manufacturer.</li> </ol>
F055	Slave Failure 7	<ol style="list-style-type: none"> <li>1. Restart the 5K0 Smart.</li> <li>2. If restarting does not resolve the issue, contact the manufacturer.</li> </ol>
F056	Slave failure 8	<ol style="list-style-type: none"> <li>1. Restart the 5K0 Smart.</li> <li>2. If restarting does not resolve the issue, contact the manufacturer.</li> </ol>
F057	Slave Failure 9	<ol style="list-style-type: none"> <li>1. Restart the 5K0 Smart.</li> <li>2. If restarting does not resolve the issue, contact the manufacturer.</li> </ol>
F058	Slave Error 10	<ol style="list-style-type: none"> <li>1. Restart the 5K0 Smart.</li> <li>2. If restarting does not resolve the issue, contact the manufacturer.</li> </ol>
F059	Slave failure 11	<ol style="list-style-type: none"> <li>1. Restart the 5K0 Smart.</li> <li>2. If restarting does not resolve the issue, contact the manufacturer.</li> </ol>
F060	Slave Error 12	<ol style="list-style-type: none"> <li>1. Restart the 5K0 Smart.</li> <li>2. If restarting does not resolve the issue, contact the manufacturer.</li> </ol>
F061	Slave Error 13	<ol style="list-style-type: none"> <li>1. Restart the 5K0 Smart.</li> <li>2. If restarting does not resolve the issue, contact the manufacturer.</li> </ol>
F062	Slave Error 14	<ol style="list-style-type: none"> <li>1. Restart the 5K0 Smart.</li> <li>2. If restarting does not resolve the issue, contact the manufacturer.</li> </ol>
F063	Slave failure 15	<ol style="list-style-type: none"> <li>1. Restart the 5K0 Smart.</li> <li>2. If restarting does not resolve the issue, contact the manufacturer.</li> </ol>
F064	Slave failure 16	<ol style="list-style-type: none"> <li>1. Restart the 5K0 Smart.</li> <li>2. If restarting does not resolve the issue, contact the manufacturer.</li> </ol>

## 7.3 Disposal out of service

At the end of the 5K0 Smart's service life, dispose of it using the Electrical Waste Disposal Act applicable at the installation location. It can also be returned to WK (Guangdong) Energy Storage Technology Co., Ltd. at its own expense.

If the Storage System will not be used in the future, the following steps are required for proper disposal.

### Procedure

- 1 Disconnect the external AC switch "BAT SWITCH" and prevent it from being reconnected by mistake.
- 2 Turn the DC switch to the "OFF" position.
- 3 Wait about 10 minutes until the internal capacitor discharges.
- 4 Remove the AC cord.
- 5 Remove the DC cable.
- 6 Remove the Storage System from the wall.
- 7 Dispose of the 5K0 Smart.
- 8 Dispose of the battery according to local requirements.

## 7.4 Quality Assurance

For quality assurance details, please refer to the corresponding Product Warranty Manual on the official website.