

Southwest Windpower, Inc.

Renewable Energy Made Simple

Owners Manual

Installation, Operation and Maintenance



***WHISPER 500
Battery Charging
Wind Generator***

Southwest Windpower, Inc.

1801 W Route 66

Flagstaff, Arizona 86001

Phone: (520)-779-9463

Fax: (520)-779-1485

Email: info@windenergy.com Web page: <http://www.windenergy.com>

IMPORTATEUR OFFICIEL FRANCE

**S.A.R.L CAPENERGIE, Mas d'alhem - 34150 - La Boissière - France
Tél : 04 67 56 77 91 - Fax : 04 67 55 52 25, E-Mail : info@capenergie.fr**

www.capenergie.fr

© 1 April 2000 Southwest Windpower , Inc

WIND GENERATOR SERIAL NUMBER _____

Southwest Windpower, Inc.
Renewable Energy Made Simple

Owners Manual
Installation, Operation and Maintenance
For Battery Charging Applications



Whisper 500
Battery Charging
Wind Generator

Southwest Windpower, Inc.
1801 W Route 66
Flagstaff, Arizona 86001
Phone: (928)-779-9463
Fax: (928)-779-1485

Email: info@windenergy.com
Web page: <http://www.windenergy.com>

© 1 April 2006 Southwest Windpower , Inc
All Right Reserved

WIND GENERATOR SERIAL NUMBER _____

BEFORE YOU BEGIN:

Read this entire manual. Following the instructions and recommendations in this manual will help assure safe and enjoyable use of your new renewable energy system.

SAFETY INFORMATION: These systems present mechanical, electrical and chemical (battery) hazards that can be life threatening. The tower or support structure could fall and cause injury or death and property destruction. A component of the wind generator could come loose causing injury or death and property destruction. Contact with the high speed propeller can result in severe injury or death. High voltage from the wind generator or the inverter can cause injury or electrocution. A burn injury can result from an electrical short. A severe chemical burn including blinding can occur from a battery explosion or contact with the sulfuric acid in a lead-acid battery.

These conditions are addressed in the following safety messages:

STOP! DANGER! It is your responsibility to obtain all required permits and engineering certifications for your tower and tower location. Soil and wind conditions vary and towers and tower foundations must be designed for your specific location. Tower must not be able to fall on occupied buildings, neighbor's property or power lines. Tower climbing is dangerous and should be attempted only by experienced personnel using proper safety equipment. A fold-over tower can eliminate climbing. Locate your mounting mast (tower) well away from occupied buildings and power lines; a minimum of 100m (300 ft) is recommended.

STOP! DANGER! If the generator appears or sounds loose in the tower or is making an unusual sound, the condition must be corrected immediately. A loose generator or component will soon damage itself further and may fall from the tower or lose parts that could be lethal. Never stand in line with an operating propeller.

STOP! DANGER! Provide climbing protection against all unauthorized persons or children. Never allow an untrained person or someone without the proper safety equipment to climb the tower. Always stop the propeller before climbing the tower. Both falling from the tower and contact with the operating propeller can be lethal.

STOP! DANGER! High voltage systems (that is, systems with battery voltages of 64 volts and above or the primary side of any system with a transformer) represent a dangerous shock hazard and could be lethal. All high voltage systems should be wired and maintained by a qualified and licensed electrician.

STOP! DANGER! Batteries may emit explosive and irritating gas while charging. Never turn on a light switch or make any other electrical connection or light a match or make any type of spark near a recently-charged battery. Use protective gloves and eyeglasses when working around a battery. Turn off all loads, wear safety glasses, and look away when making a final battery connection.

STOP! DANGER! NEVER place objects on top or near the Whisper Controller enclosure, diversion load, transformer, Aurora Wind Interface or inverter, when applicable. These devices must dissipate heat as part of normal operation. FIRE AND FAILURE can result if airflow is blocked.

TABLE OF CONTENTS

Section	Page
1. Introduction	4
2. Controller and Diversion Load Installation	6
3. Wire Connections	7
Controller to Battery Connections	7
Controller to Wind Generator Wiring	8
Brake Switch	10
Diversion Load Wiring and Configuration	11
Transformer	11
4. Wind Generator Installation	13
Electrical Tests	13
Install Tower Insert	14
Install Tail Fin	17
Install Tail Boom	19
Install Blades and Nosecone	20
5. Whisper Controller	22
Printed Circuit Board Switch Settings	22
Optional Equipment	24
Controller Operation	26
6. Maintenance	32
7. Troubleshooting	35
Mechanical repairs and parts replacement	38

1. Introduction

System Voltage

All system components, Wind Generator, Whisper Controller, diversion load, transformer and inverter (if applicable), must be configured to the correct system voltage.

The Whisper 500 Low Voltage (LV) Wind Generator is factory set at 48 volts, and the Whisper 500 High Voltage (HV) Wind Generator is factory set at 240volts. The Whisper 500 Controller is also factory set at 48 volts. for the See TROUBLE SHOOTING AND REPAIR section to change the Whisper 500 voltage from the standard voltage. Refer to the appropriate sections in this manual to configure the Wind Generator or Controller to different voltages.

Battery Bank Size

Southwest Windpower recommends a 48 volt Whisper 500 have a battery bank with a minimum of 400 amp-hours of capacity, and a 24 volt Whisper 500 should have a battery bank with a minimum of 800 amp-hours of capacity.

Tower

The Whisper 500 Wind Generator is designed to fit on a 5-inch schedule 40 steel pipe. The minimum recommended tower height is 7 meters (20 feet) above trees or obstacles within 100m (300ft).

The lateral thrust load produced by the Whisper 500 at a wind speed of 45 m/s (100 mph) is 3.6 kN (800 lbs).

The highest point on your property is generally best location to site the wind generator but the distance to the batteries and the system voltage will figure in the determining the correct installation location.

Wiring and Wire Sizes

The Battery Charging schematic on the following page depicts the wire runs and connections required to install a typical Battery Charging system. Note not all systems require the voltage transformer or optional external brake switch.

Wire sizes depend largely on the length of wire, system voltage and power transmitted. Wire is expensive. Site your wind generator accordingly.

Whisper 500 Battery Charging Schematic

You will need to make the electrical connections as shown below.

**Whisper 500
Wind Generator**

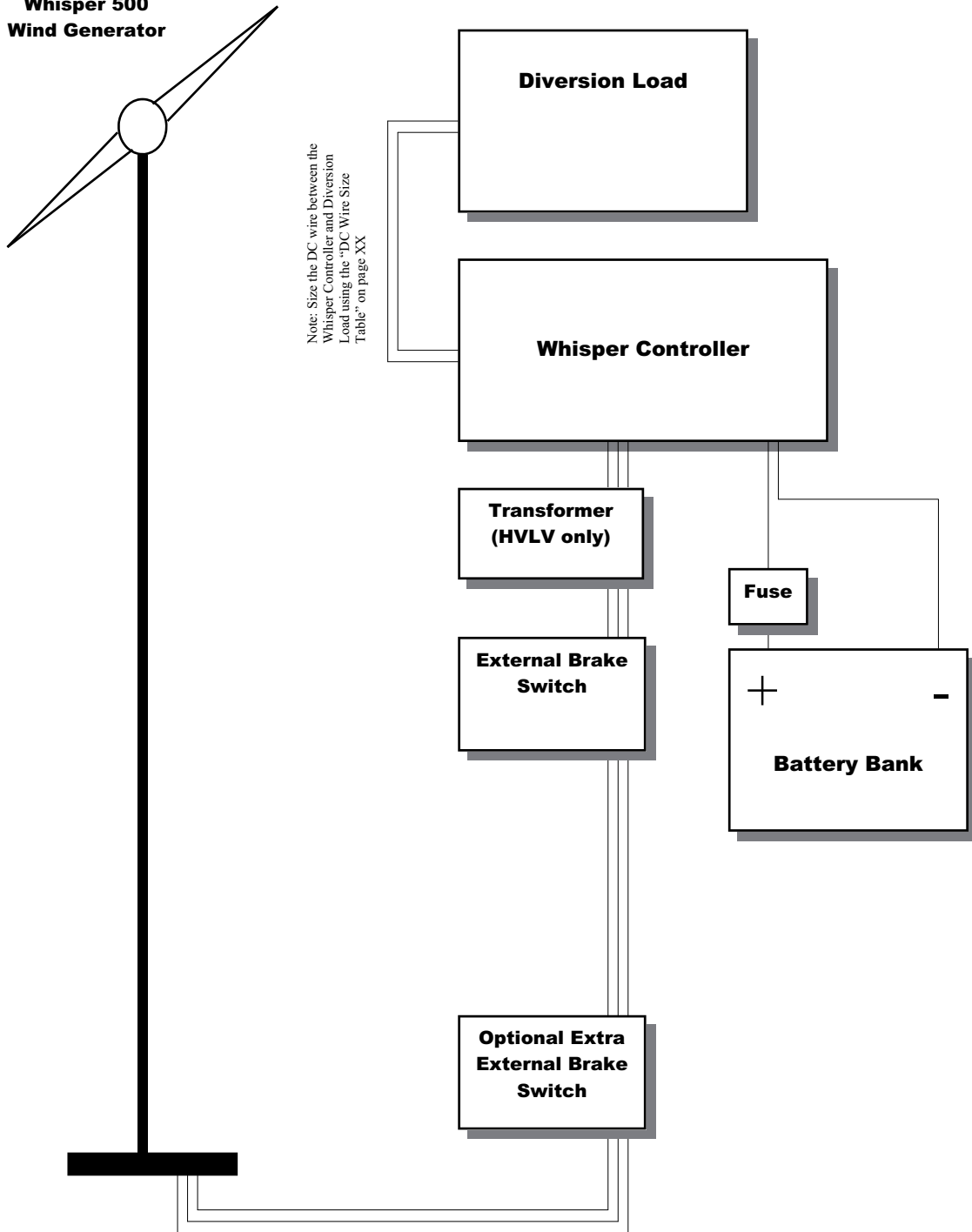

Note: Size the DC wire between the Whisper Controller and Diversión Load using the "DC Wire Size Table" on page XX

Note: Size the three phase wire between the turbine and Whisper Controller using the "Wire Size: Mast top to Whisper Controller table on page XX

2. Controller and Diversion Load Installation

Whisper 500 Controller and 4600 Diversion Load

The Whisper 500 Controller **MUST** be mounted vertically on a wall as shown below. Even though the Whisper 500 Controller does not contain a diversion load, this mounting position is necessary to provide adequate cooling for the electronics and rectifier heat sink.

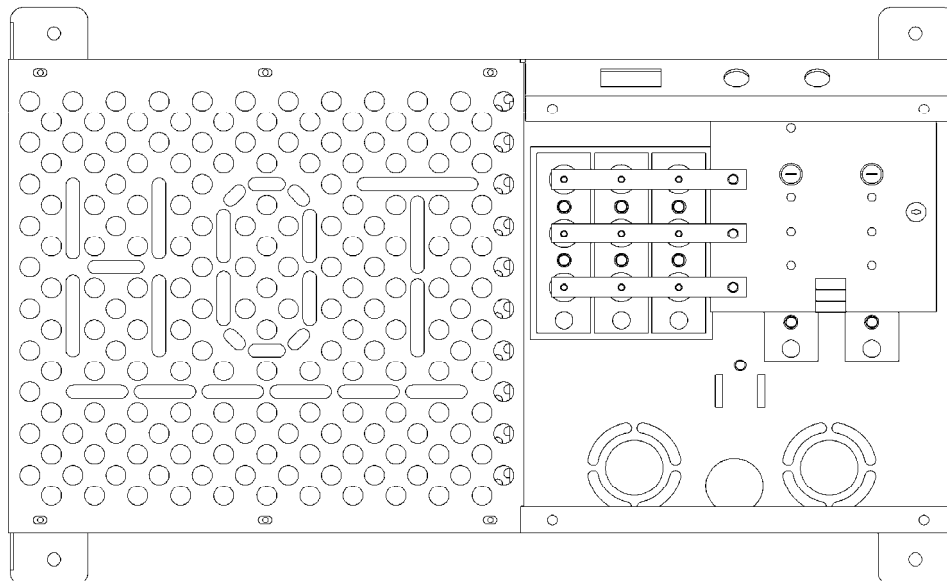

The 4600 Diversion Load **MUST** be mounted against a wall to provide adequate heat transfer. The controller must be mounted within 5 feet (1.5 meter) of the diversion load due to the precut wire length. Do not mount the diversion load within 10 feet (3 meters) of flammable materials or near heat sensitive components. Do not mount the controller above the diversion load since the heat from the diversion load may overheat the controller.

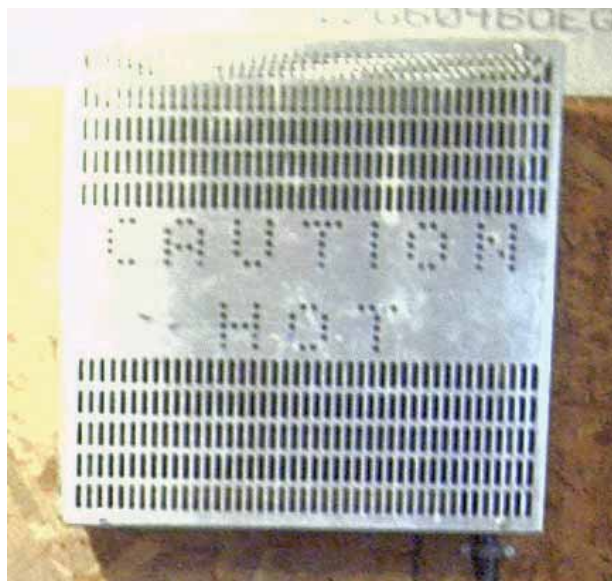

3. Wire Connections

Controller to Battery Connections

Remove the Whisper Controller Electronic Cover and connect the battery and ground wires as shown in the accompanying figures. **Caution: Southwest Windpower strongly recommends connecting the Controller to the batteries BEFORE making the wind turbine connections.**

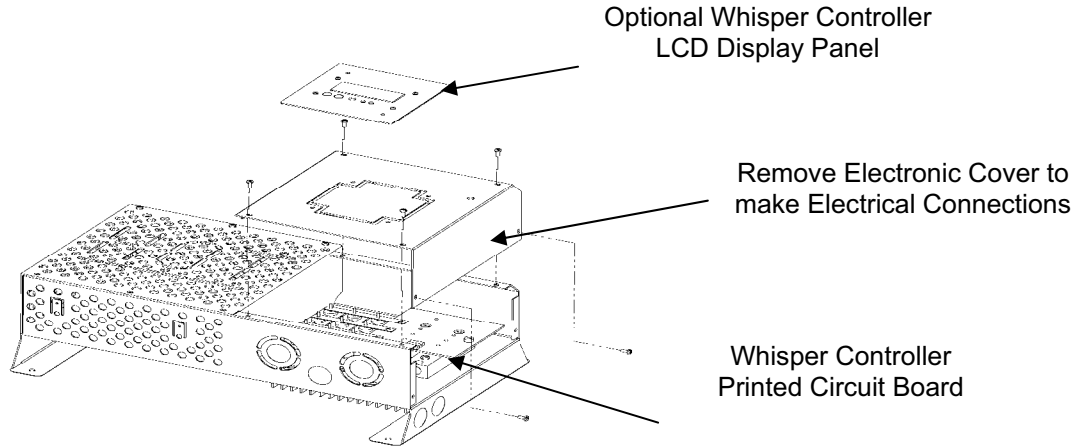

Refer to the following sections to select the correct gauge wire to connect the controller to the batteries. Use caution when connecting the battery leads to avoid shorting them together. Correct polarity **MUST** be observed when connecting the battery cables.

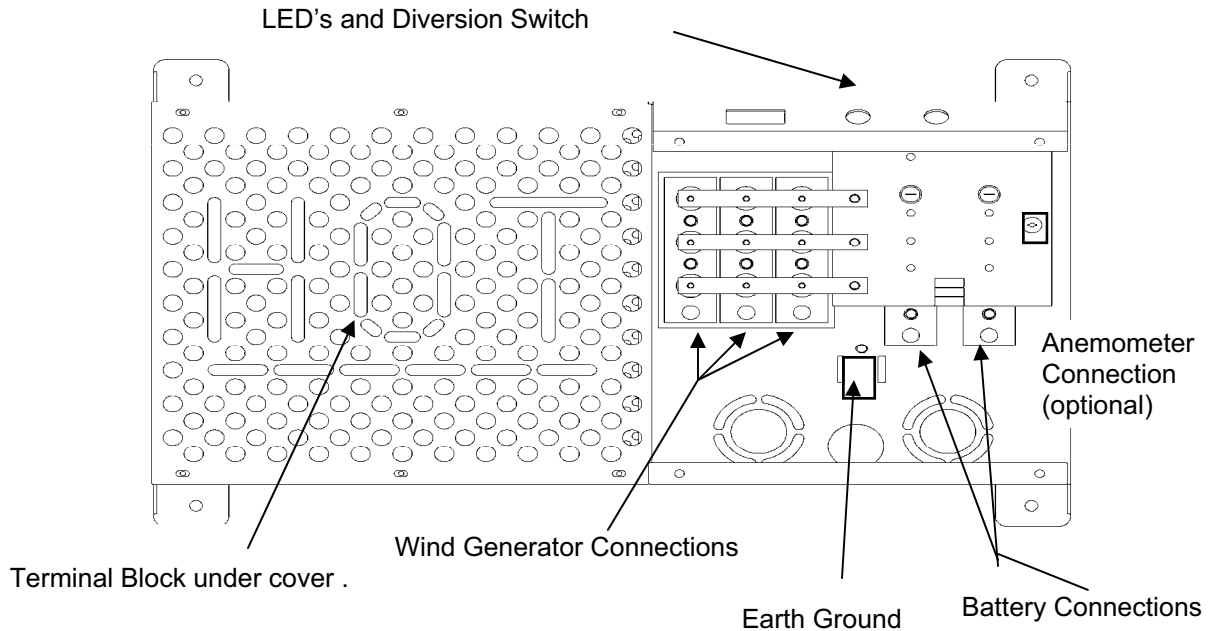

Depending on your system voltage, wire the controller to the battery system by select the appropriate size wire from the list below:

- 24 Volt Systems — Use 2 AWG wire or larger**
- 48 Volt Systems — Use 6 AWG wire or larger**

Controller to Wind Generator Wiring

Southwest Windpower strongly recommends connecting the controller to the batteries prior to connecting the wind generator to the controller.

After connecting the controller to the batteries proceed by connecting the three wires from the wind generator to the controller as shown below. Note that the order of the wires is not important. Any wire from the wind generator may be installed in any of the wind generator input terminals.

Note: Refer to the following section to install the Brake Switch in parallel with the Whisper 500 and the Whisper Controller.

The size of the wire required to connect the Whisper Controller to the wind generator is determined by the power produced by the generator, system voltage and the distance between the generator and controller. Distances are one way and should include the height of the tower.

Refer to the accompanying charts to determine the correct wire size for your system. The wire sizes listed in the charts provide a 95% transmission efficiency in an area with a 12 mph average wind speed.

To use the charts measure distance from Whisper Controller to wind generator. Find the closest distance listed in the column for your system voltage and read the wire size to the left of the distance. Note if your measured distance is nearly midway between two distances on the chart it is probably best to select the larger size wire. This is particularly true in areas with higher wind speeds. Distances are listed in both feet and meters.

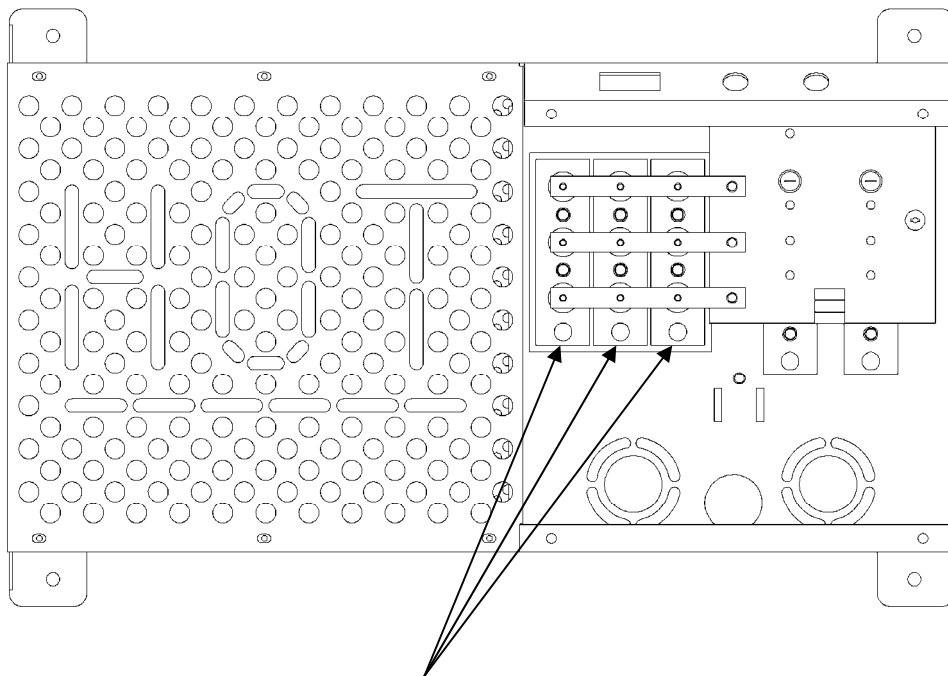

Wind Generator Input Terminals

Connect three wires from wind generator to terminals. Order of connection is not important.

Whisper 500 — Controller to Wind Generator Wire Size Table									
Wire Size ▼	System Voltage				Wire Size ▼	System Voltage			
	24	36	48	240**		24	36	48	240**
14 AWG	xx	xx	xx	903	14 AWG	xx	xx	xx	xx
12	xx	xx	xx	1442	12	xx	xx	xx	xx
10	xx	xx	xx	2296	10	xx	xx	xx	56
8	xx	xx	145	3637	8	xx	xx	44	89
6	xx	113	226	5653	6	xx	34	69	138
4	90	181	361	9037	4	28	55	110	220
3	114	227	455	11363	3	35	69	139	277
2	143	287	573	14330	2	44	87	175	349
1	183	366	732		1	56	112	223	447
0	227	455	909		0	69	139	277	554
2/0	288	577	1154		2/0	88	176	352	703
3/0	363	726	1452		3/0	111	221	442	885
4/0	459	918	1837		4/0	140	280	560	1120
▲	Distance (Feet)				▲	Distance (Meters)			

**** Note: The Whisper 500 High Voltage cannot be wired directly to the Whisper Controller. A step down voltage transformer is required to reduce the voltage to 24, 36 or 48 volts before connection to the Whisper Controller.**

AWG to Metric Wire Size Conversion Chart

The following chart may be used to convert from American Wire Gauge (AWG) to metric wire size.

AWG to Metric Wire Size Conversion Chart			
AWG gauge	Diameter (mm)	AWG gauge	Diameter (mm)
0000 (4/0)	11.68 mm	4	5.19 mm
000 (3/0)	10.40 mm	6	4.11 mm
00 (2/0)	9.27 mm	8	3.26 mm
0 (1/0)	8.25 mm	10	2.59 mm
1	7.34 mm	12	2.05 mm
2	6.54 mm	14	1.63 mm
3	5.83 mm	16	1.29 mm

Install Brake Switch

Mount the brake switch next to the Whisper Controller on 500LV applications or near the transformer with the 500HVLV. The brake switch should be connected in parallel with the three transmission wires between the wind generator and the Whisper Controller (or transformer for HVLV systems). The brake switch operates simply by shorting all three wires together to generate braking torque on the propellers.

Note:
Disregard the original “on” and “off” marking on the switch. Moving the switch up is “brake on”, and moving it down is “normal operation”.

Use three #6 AWG wires to connect a wire in parallel with each of the three phases from the Whisper Controller. The three wires are connected to the three different terminals indicated on the figure to the right. The order of the three wires does not matter.

IMPORTANT: be certain the switch is between the turbine and transformer, and not between the transformer and Whisper Controller (ie brake switch is on primary side of step-down transformer).

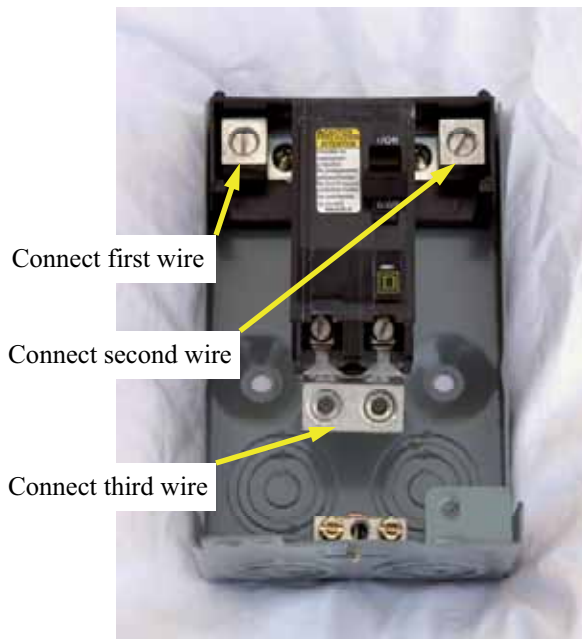

To Stop the Wind Turbine

Move brake switch handle up.

If the wind turbine blades do not stop in 30 seconds. Move handle down, wait for wind speed to decrease and retry.

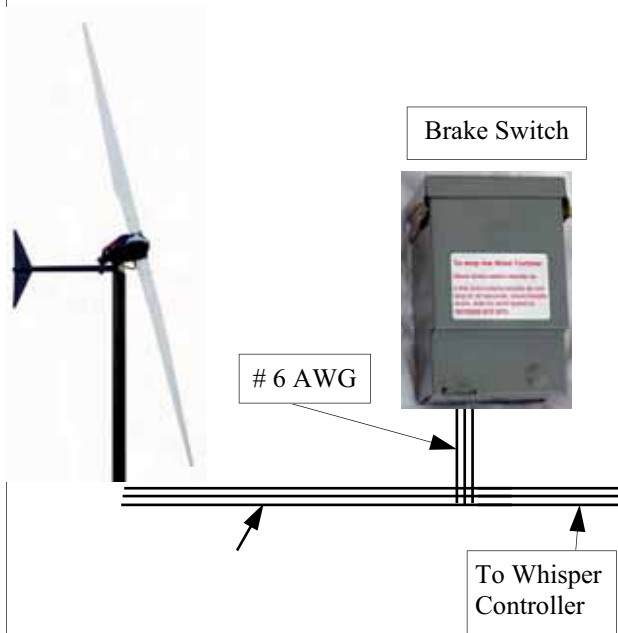
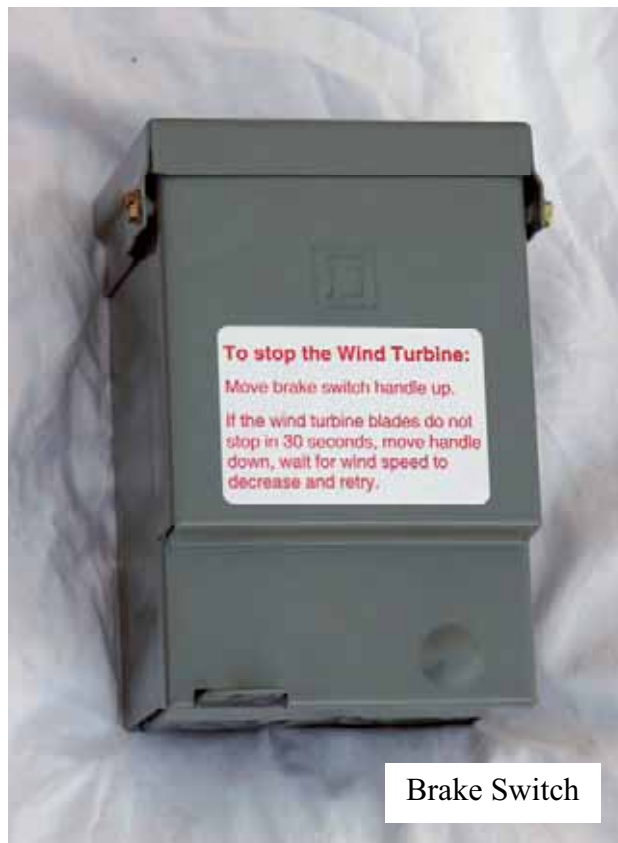

Diversions Load Wiring and Configuration

The Whisper 4600 Diversion Load includes four 8 AWG wires (labeled Red, Red 1, Black and Black 1) for connection to the terminal block in the Whisper Controller. To access the terminal block remove the left side controller cover and connect the wires as shown in the below depictions of the terminal block. Be sure to wire the terminal block for your system voltage - either 24 or 48 volts.

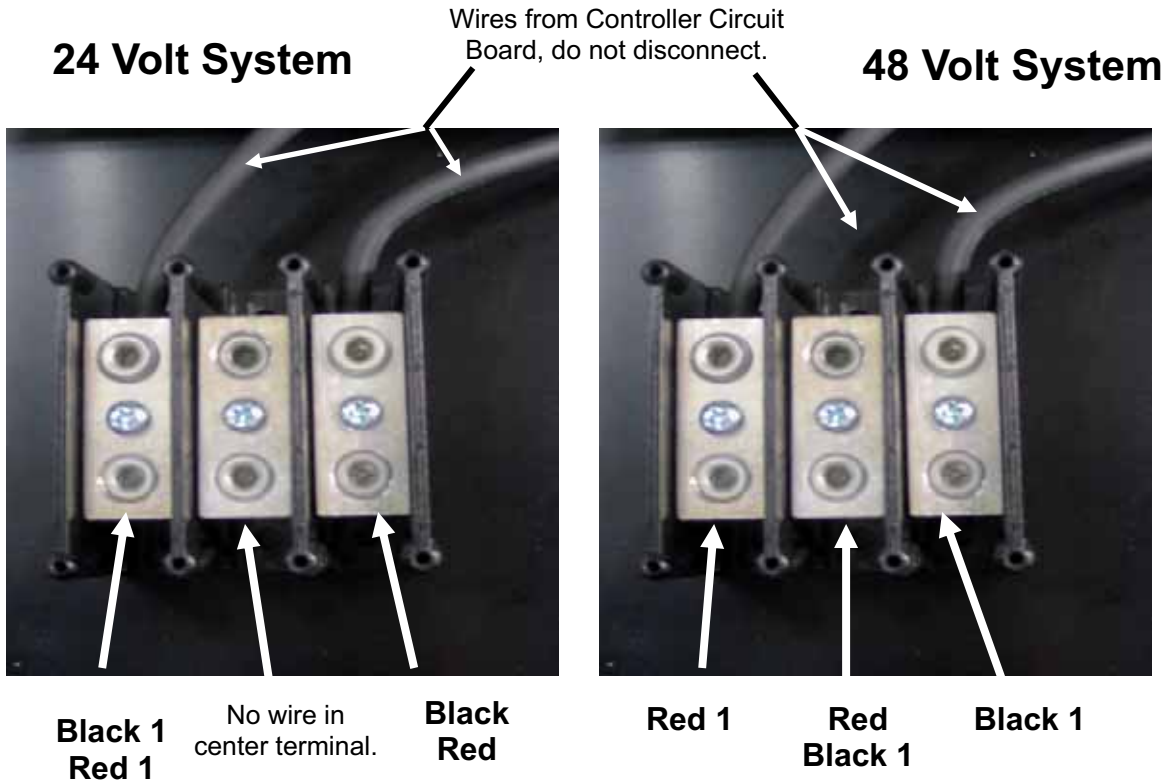

Transformer (High Voltage Only)

Install transformer on heat resistant surface with adequate ventilation. The Whisper 500 voltage is “stepped” down to 24, 36 or 48 volts with utilizing the transformer. Refer to the chart on the following page for specific directions for configuring the transformer voltage.

Transformer (Continued - High Voltage Only)

Install transformer on heat resistant surface with adequate ventilation. The Whisper 500 voltage is “stepped” down to 24, 36 or 48 volts with utilizing the transformer. Refer to the chart below for specific wiring directions for configuring the transformer voltage.

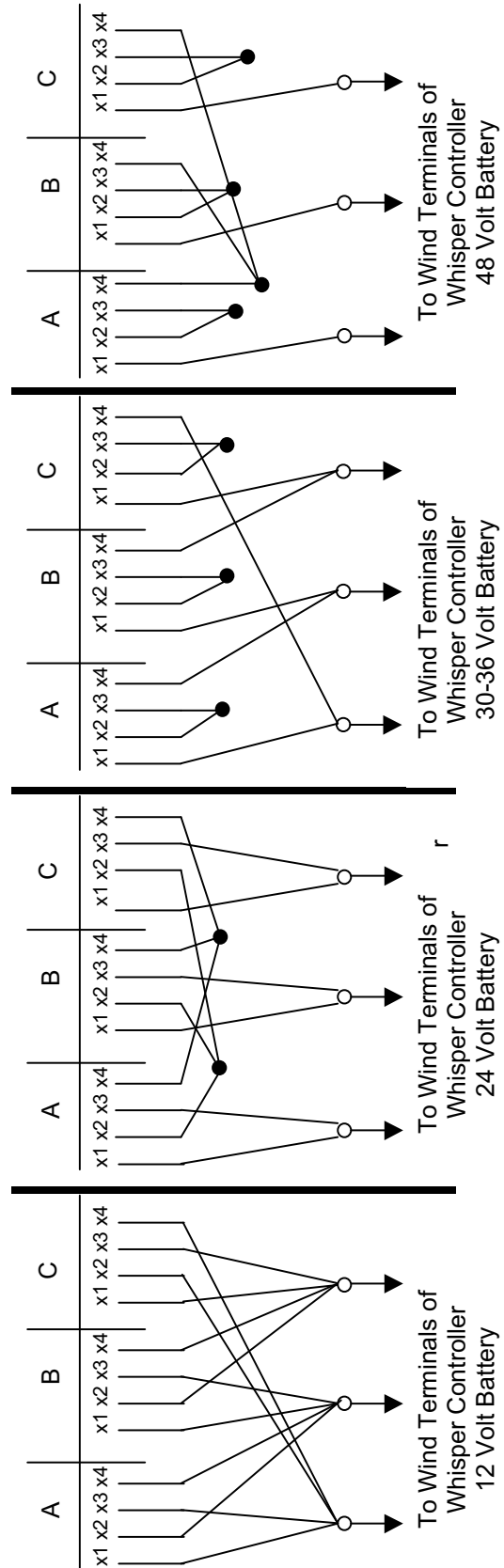
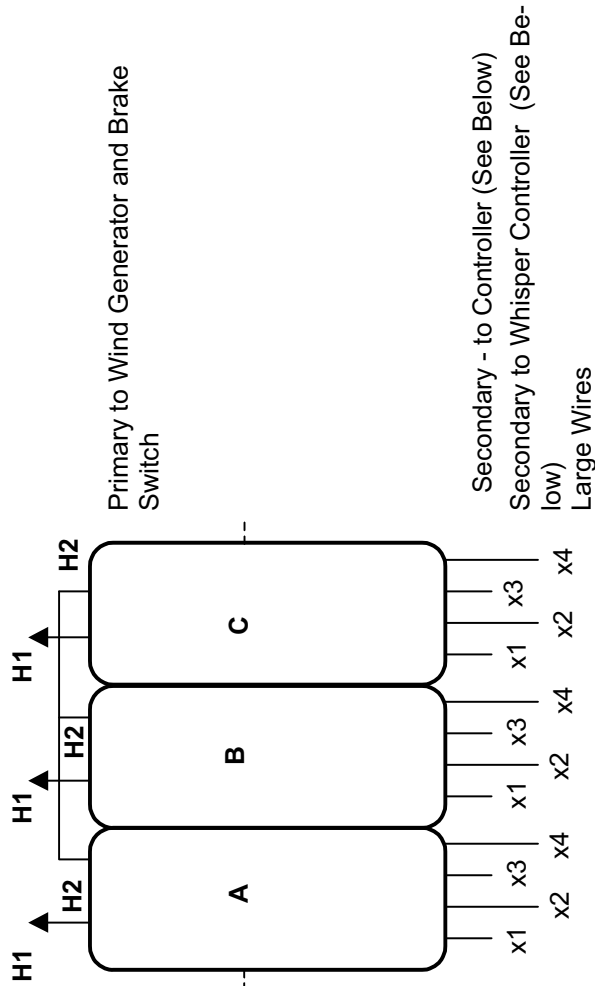

4. Wind Generator Installation

Electrical Tests

Complete these tests before mounting blades to rotor, and before installing turbine to top of tower. These tests confirm that the wind generator is functional and ready to install on the tower.

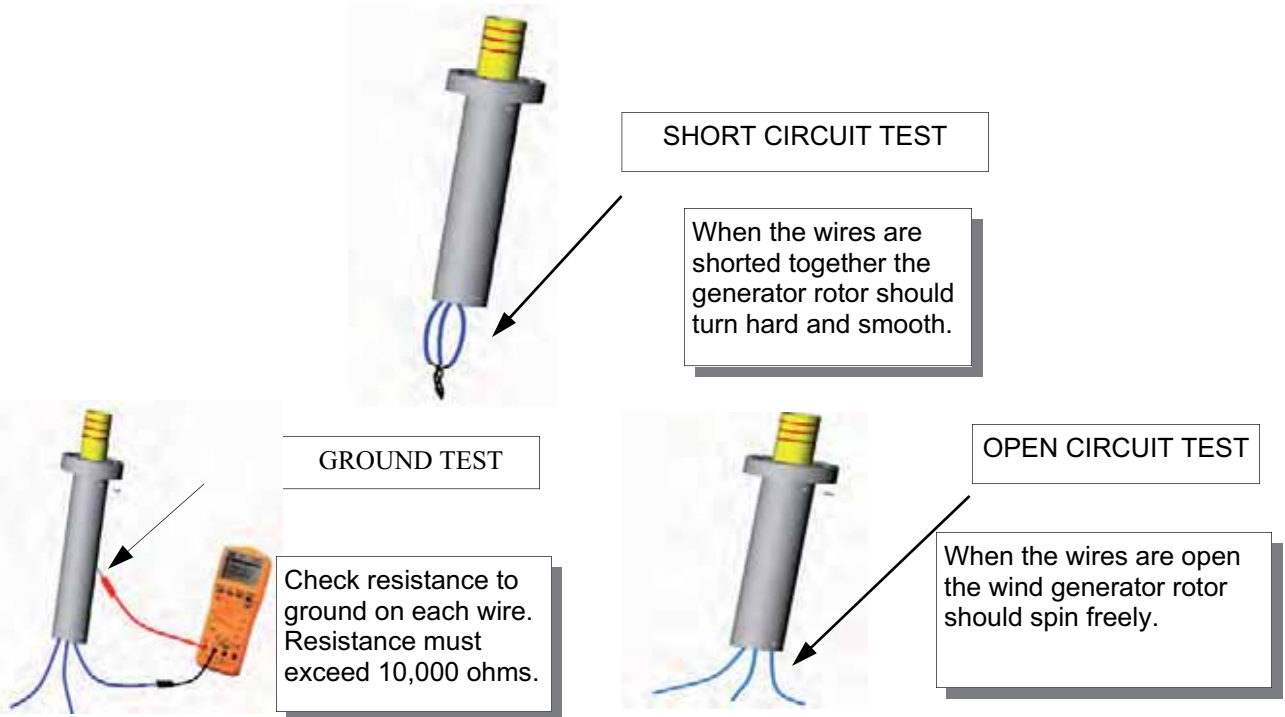

Drill Tower top Holes

Drill the six 1/2" (12.7mm) holes in the top of the tower using the foldout template at the end of this manual. You must use a sharp drill bit and a powerful drill to make these holes in steel pipe. Applying a cutting fluid at the tip of the drill bit can improve the performance and longevity of the bit. Debur the six holes, and then check the fit of the tower insert in the top of the tower. The six holes in the insert should match the six holes you just drilled.

Install Tower Insert on Yaw Shaft

<u>Part #</u>	<u>Part Description</u>	<u>Qty</u>
IAC14A	5" tower insert	1
IAR98	M10x55 Grade 10.9 zinc bolt	3
IAR99	M10 zinc lockwasher	3
IAR43	M8x30 SS set screw	3
IAR17	M8 SS nylock hex nut	3
IAR29	4mm short arm allen wrench	1
IAR41	M10x25 SS hex bolt	6
IAR40	M10 SS lockwasher	6



Mounting Instructions

A) Check the fit and hole alignment of the tower insert inside tower, before installing it on the yaw shaft. The six holes you just drilled in the tower pipe should line up with the six holes in the tower insert. A maximum of 1.5mm (1/16in) play is allowed. Tower Pipe or tube must be tight against insert when the mounting bolts are tightened.



B) Install the tower insert onto the yaw shaft. Place the three M10x55 screws into the tower insert and thread them into the yaw shaft. Be sure to use the three M10 zinc lock washers on these screws. Tighten with a 17mm socket.



C) Finger-tighten the nylock nuts over the three M8x30 set screws. Tighten the three M8x30 set screws on the upper holes using the supplied allen wrench. After the set-screw is tightened with the allen wrench, tighten the nylock nut over the set-screw using a 13mm deep socket. You must use a deep socket with this nut because a regular socket will slip off the nut before the nut is fully tight, and result in an unsafe attachment between the turbine and tower.



Connect Wires and Mount Wind Generator To Tower

Mounting Instructions

- A) Use split bolts to make the electrical connection between the yaw wires and the transmission wires inside the tower. Any of the three yaw wires can go to any of the three transmission wires. Use heat-shrink and electrical tape to fully insulate these connections from each other and any surrounding metal.
- B) Attach some type of strain relief inside the tower to support the weight of the wires. See figure on the right. It is important that the full weight of the wires is not being supported by the slip rings on the yaw shaft.
- C) Install the turbine, without the blades, onto the tower top. Be careful not to pinch or short any of the wires. Rotate the tower insert so the six holes in the tower match the corresponding threaded holes in the tower insert.
- D) Tighten the six M10x25 screws through the holes on the outside of the tower pipe into the tower insert. Be sure to use the lockwasher on each of these screws. Tighten these six screws with a 17mm socket.
- E) The turbine should now be fully attached to the tower top.

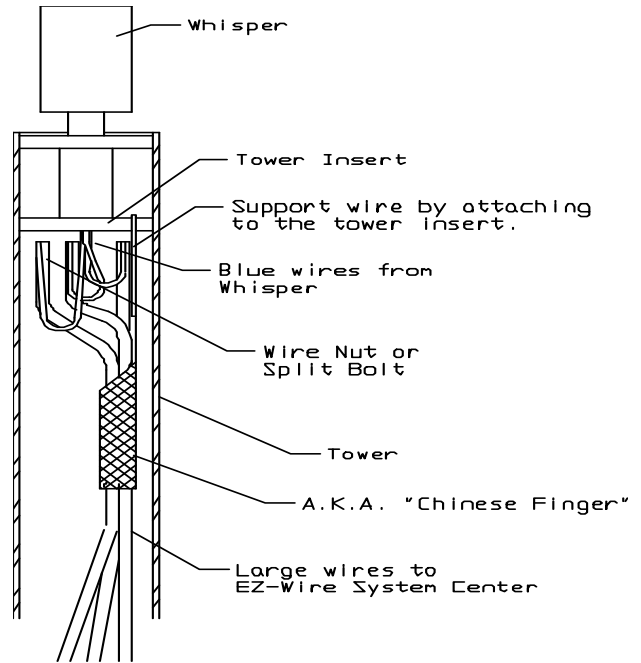

Test Wind Generator to Whisper Controller Wiring

Repeat WIND GENERATOR ELECTRICAL TESTS. This time use the brake switch to short the wires, and measure the resistance between the phase and ground at the connection to the Whisper Controller.

- Short Circuit Test = Brake handle up
- Open Circuit Test = Brake handle down

Do not install the blades until each of these test OK.

Hardware

Lay out the hardware contained in the Whisper 500 Hardware Kit and separate as appropriate. You will need metric sockets and wrenches to complete the installation.

<u>Item</u>	<u>Part #</u>	<u>Part Description</u>	<u>Qty</u>	<u>Place used</u>
1	IAR15	M8x 24 SS flatwasher	10	Tail strap to tail fin & Tail strap to tail boom & Tail boom through-bolt & Nose cone
2	IAR16	M8x31 nylon flatwasher	16	Tail fin to tail boom & Tail strap to tail fin
3	IAR52	M8x24 nylon flatwasher	2	Nose cone
4	IAR07	M8x20 SS hex screw	2	Nose cone
5	IAR35	M8x30 SS bolt	7	Tail fin to tail boom & Tail boom to lower weldment
6	IAR42	M8x90 SS bolt	1	Tail boom through-bolt
7	IAR59	M10x80 zinc bolt	8	Blades
8	IAR31	M8x80 SS bolt	1	Tail strap to tail boom
9	IAR30	M8x40 SS bolt	2	Tail strap to tail fin
10	IAR14	M8 SS lockwasher	2	Nose cone
11	IAQ13	3/4" tube spacer	2	Tail strap
12	IAR17	M8 SS nylock	11	Tail strap to tail fin & Tail strap to tail boom & Tail fin to tail boom & Tail boom through-bolt & Tail boom to lower weldment
13	IAR50	M10 SS nylock	8	Blades



Install Tail Fin and Strap

Before installing the tail boom into the lower weldment, install the Tail fin and Tail strap as shown in the following pictures. The numbers with arrows refer to the item number in the table from Step 15.

Mounting Instructions

- A) Connect one of the fins to the tail boom with a nylon washer sandwiched between the metal tabs on the tail boom and the tail fin. Repeat so the fin is secured with three bolts
- B) Repeat the above step for the second fin, but use only two of the three holes so the fin looks like the picture below (minus the tail strap).

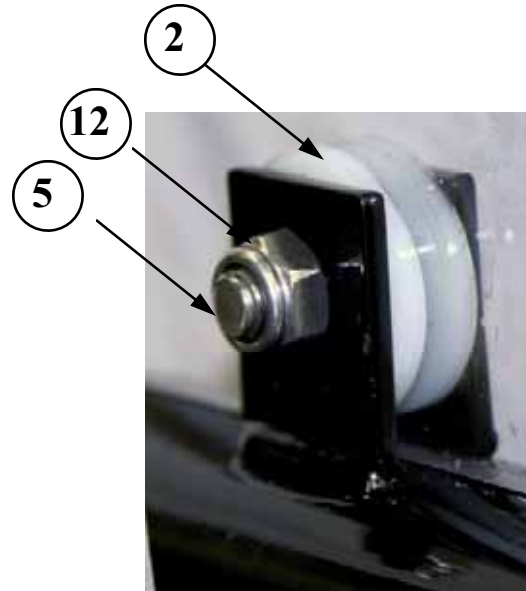

- C) Attach the through-bolt as show with SS washers outside the tail strap. The 3/4" tube spacer is between the tail strap and the tabs on the tail boom. The nylon flatwashers are between the tail boom tabs and the tail fin. At this point, only finger tighten the nylock nut.

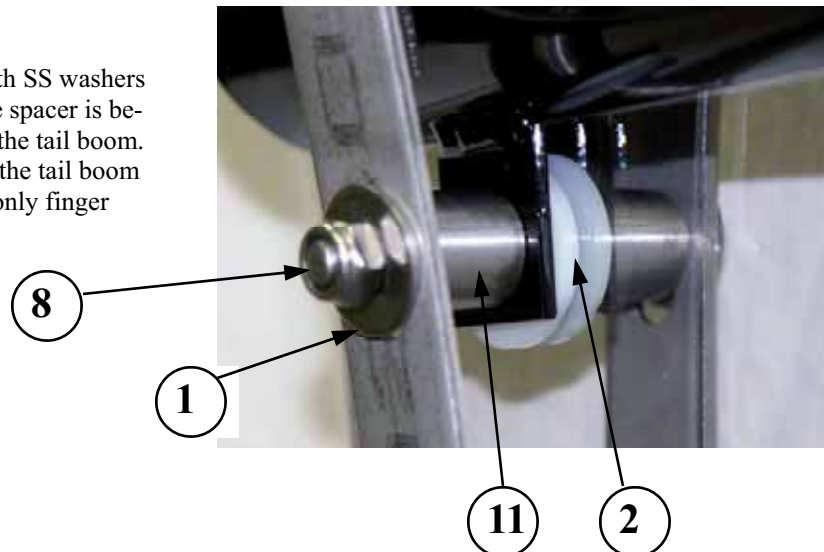

D) Note how one side of the tail strap has a hole and the other is a slot. Attach the side with the hole to the tail fin as show to the right. A stainless steel washer is used on the outside of the tail strap. A nylon washer is sandwiched between the tail strap and tail fin. At this point, only finger tighten the nylock nut.

E) Then place the bolt in the side of the strap with the slot. Finger tighten the nylock nut.

F) Use a 13mm socket and a wrench to tighten all three bolts connecting the tail strap to the tail fin.

G) The tail fin should now be securely fasten to the tail boom and should look like the last picture on this page.

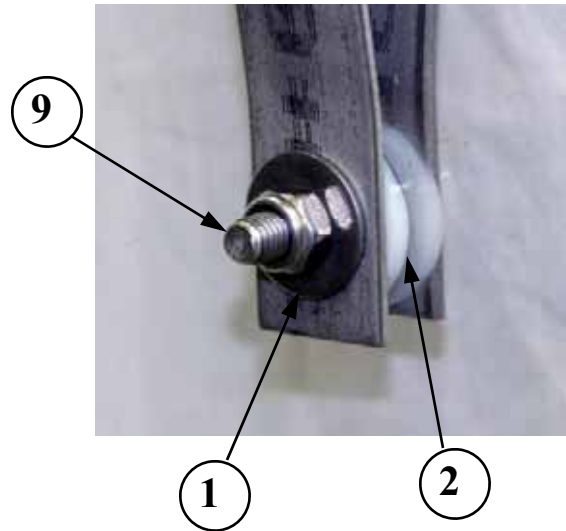

Install Tail Boom to Lower Weldment

The numbers with arrows refer to the item number in the table from Step 15.

Mounting Instructions

Insert the tail boom into the lower weldment. Be sure the tail fins will be vertical when the tower is raised. You may need to tap the tail boom into the weldment with a rubber mallet or a piece of wood and a sledgehammer.

Insert the tail boom into the lower weldment until the hole in the lower weldment matches the through-hole in the tail boom. If the holes are nearly lined up, but not perfect, then you may want to run a drill through the tail boom so the through-bolt will go through (if it was difficult to get the tail boom inserted into the lower weldment).



Install the long through-bolt with stainless steel washers and a nylock nut and tighten with a socket and wrench.

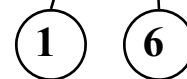

Install the two compression bolts to the lower weldment, and tighten with a socket and wrench.

The tail boom should now be securely attached to the lower weldment.



Install Blades, Blade Strap and Nosecone

It is very important the blades are installed properly and not backwards. When looking at the front of the turbine from an *upwind* position, the leading edge tape should be as shown in the picture to the right. When looking at the blades from an *upwind* position, they will rotate in a clockwise direction.

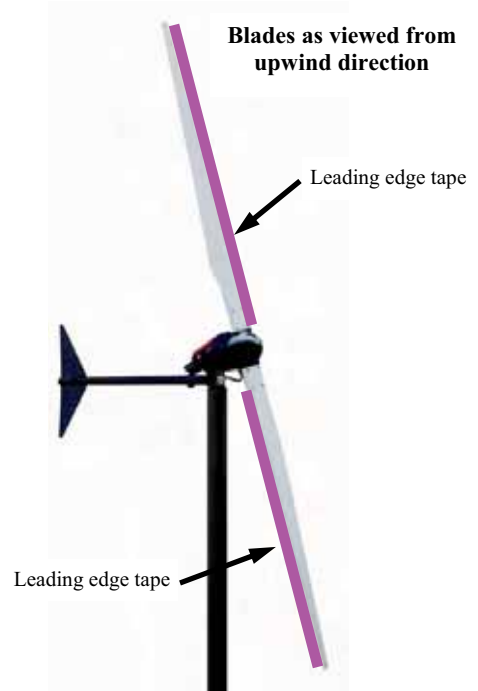
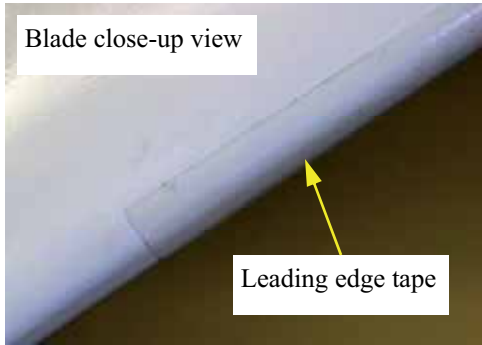

Install the blade bolts with the head of the bolt against the hub plate as shown in the figure to the right. It is important that the threads of the bolts are pointing into the wind.

7

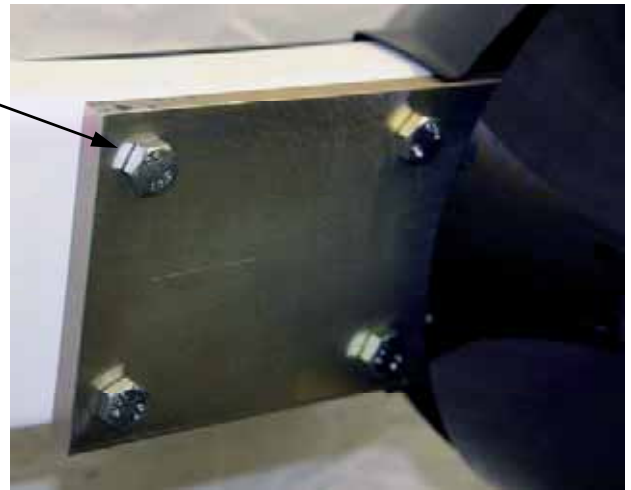

Place the blade straps across the front of the blades, and tighten the nuts to 18 foot-lbs of torque.

13

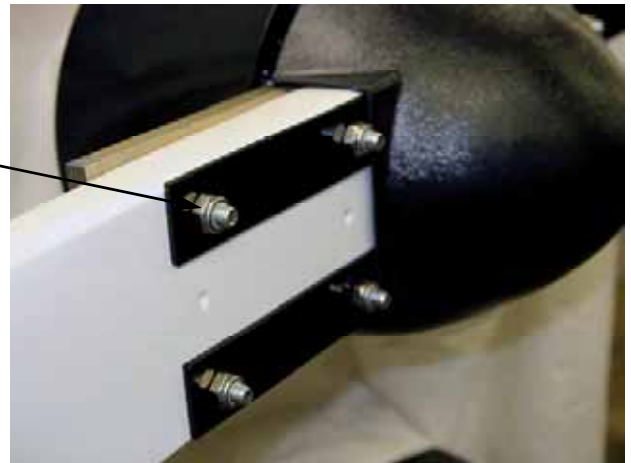

Install the nosecone using the two M8x20 stainless steel hex screws. Use a M8 split lockwasher, M8 flat stainless steel washer, and the M8x24 nylon washer, as shown in the close-up view. The nylon washer is sandwiched between the nose cone and the stainless steel flat washer. A removable threadlocking compound should be used on these two screws.

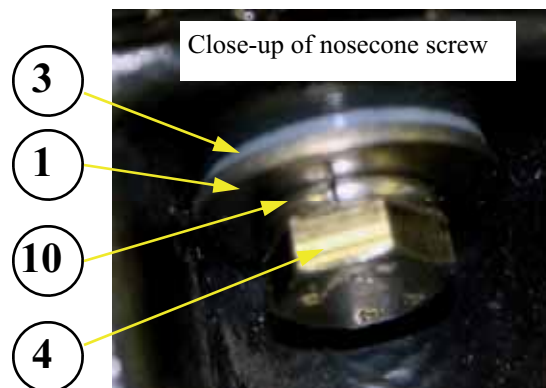

The blades and nosecone should now be securely fastened to the wind generator.

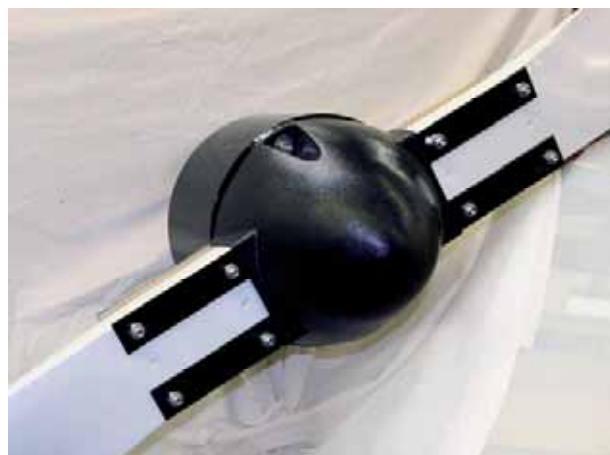

Raise Tower and Begin Generating Electricity from the Wind

Raise the tower with the brake switch engaged. Follow the tower manufacturer's instructions. After the tower is securely raised, and all system connections are double checked, then turn off the brake switch, and begin generating electricity from the wind.

IMPORTANT: Do not turn on the wind generator if the battery is not connected to the controller. Never operate the Whisper 500 without the battery properly connected to the Whisper Controller.

IMPORTANT: The battery bank must have some charge on it for the wind generator to begin charging (ie do not connect a dead battery to the wind generator).

Refer to the *Whisper Controller Owner's Manual*, for details regarding the operation of the Whisper Controller.

Operation of the wind generator propeller:

In winds below 7-9mph (3-4 m/s) the propeller will not start from a dead stop. In winds above 7-9 mph (3-4 m/s), the propeller will begin to turn slowly, and after 1 to 10 minutes, depending on the wind, it will reach an rpm where the blades are nearly invisible. Once started the propeller will continue operating in winds as low as 2m/s (4mph).

In normal winds the charging current will begin in winds above 7-9mph (3-4 m/s) and increase rapidly with

5. Whisper Controller Printed Circuit Board

Introduction

The Whisper Controller Printed Circuit Board is equipped with six switches that are used to set certain operating system parameters. The default switch settings are suitable for the majority of installations and should not be changed with the exception of two switches that **MUST** be changed to alter the system voltage.

Instructions for changing the system voltage are given below.

The printed circuit board is also equipped with a "Reset" switch that is used to reset the microprocessor. Depressing the switch has the same effect as disconnecting a battery cable from the Whisper Controller.

Note that if voltage regulation points are set using the Optional Display they will be lost if the Reset Switch is depressed or a battery cable is disconnected. In this case the controller will revert to the potentiometer set points. Refer to sections on Reset Switch, Adjusting the System Voltage and Optional Display for additional information.

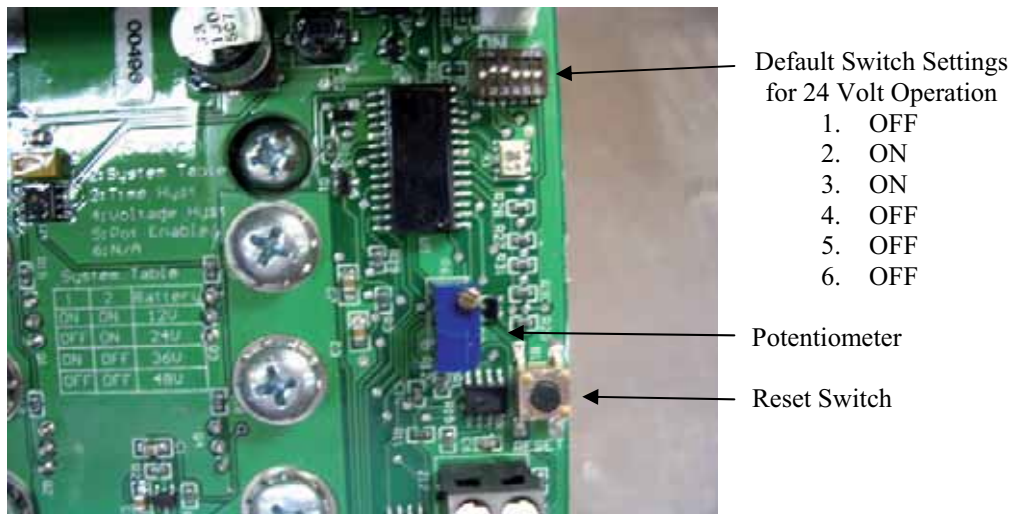

Printed Circuit Board Switch Settings

Switches 1 and 2, System Voltage

Select the correct system voltage by setting the position of Switches 1 and 2 according to the following table.

System Voltage	Switch 1	Switch 2
12 Volt	ON	ON
24 Volt	OFF	ON
36 Volt	ON	OFF
48 Volt	OFF	OFF

After changing the system voltage depress the Reset switch to "read and save" the new voltage setting.

Printed Circuit Board Switch Settings (continued)

Switch 3, Time Hysteresis, Default Setting "ON"

With Switch 3 set to "ON" the Whisper Controller implements a 30-40 second time delay for both the voltage on and off regulation set points. For example the Whisper Controller will continue charging batteries for 30-40 seconds after the voltage regulation-on set point is achieved and will not resume charging until 30-40 seconds after the regulation-off set point is achieved.

With Switch 3 set to "OFF" the Whisper will start and stop charging the batteries immediately at the voltage regulation set points. It is not necessary to depress the Reset Switch after changing the switch setting.

Note: Except in very special circumstances Southwest Windpower recommends Switch 3 remain in the "ON" position.

Switch 4, Voltage Hysteresis, Default Setting "OFF"

With Switch 4 set to "OFF" the Whisper Controller will start and stop charging the batteries at the voltage regulation set points established either through the Optional Display or by the printed circuit board potentiometer.

With Switch 4 set to "ON" the voltage regulation-on point (the point battery charging stops) set using the potentiometer will be increased by 1.0 volts for 12 volt system, 2.0 volts for 24 volt systems, 3.0 volts for 36 volts systems and 4.0 volts for 48 volt systems. The voltage regulation-off set point (the point battery charging resumes) is unaffected by setting the switch to "ON".

The Voltage Hysteresis Switch does not increase the regulation-on and off set points set using the Optional Display. In other words it is not additive with the Optional Display set points. It is not necessary to depress the Reset Switch after changing the switch setting.

Switch 5, Potentiometer Enable, Default Setting "OFF"

Switch 5 in the "ON" position enables reading the potentiometer voltage on the Optional Display in real time. The resolution limits of the display are 0.2, 0.4 and 0.8 volts for 12, 24 and 48 volt systems respectively.

With the Switch set to "ON", voltage regulation points may not be set using the Optional Display. They must set using the potentiometer.

With the Switch set to "OFF" prevents changing the voltage regulation set point by the potentiometer. It is not necessary to depress the Reset Switch after changing the switch setting.

Switch 6, Default Setting "OFF"

There is no function presently associated with this switch. It is recommended to leave the switch in the "OFF" position.

Whisper Controller Reset Switch

Operation of the Whisper Controller is controlled by a microprocessor and software contained on the Whisper

Controller printed circuit board. A reset switch is provided as means to restart the microprocessor and operating control software without needing to disconnect battery power.

To reset the microprocessor momentarily press the reset button. The location of the button is depicted on the previous page. If it is necessary to depress the switch a second time allow approximately 15 seconds before depressing the switch a second time.

Note that if custom voltage regulation on and off voltage regulation points are set using the optional display, these settings will be lost when the reset switch is depressed and the Whisper Controller reverts to the potentiometer voltage setting. The values are also lost if the battery is disconnected.

Optional Equipment

Display (Liquid Crystal Display - LCD)

Display Installation

The optional LCD display may be mounted either on the Whisper Controller base unit, or in a standard 4" wall type switch receptacle. Mounting hardware is provided with the display. An ethernet CAT5 cable is provided to mount the display on the Controller base.

To mount the display directly on the Whisper Controller remove the electronics cover and knock out the sheet metal insert where the display is to be mounted. Refer to the figure below. There are pre-drilled holes to mount the display. Use the 8-32 x 3/8", black oxide, stainless steel screws, and 8-32 nuts with captive star washers provided to mount the display on the electronics cover.

Connect the display cable to the CAT5 jack located nearest the diversion switch. This will indicate to the display that it is locally mounted and it will disable its LED features, since these are redundant to those mounted on the Whisper Controller base. Leave the cover off until the display function is verified.

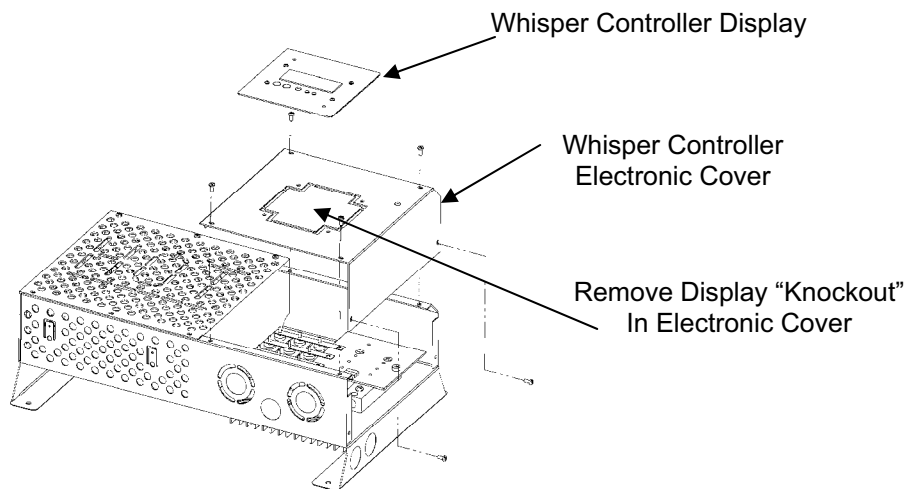

Remote LCD Display Installation

The display may be located up to 300 meters / 1000 feet from the Whisper Controller. Use Category 5 ethernet cable. The cable with connectors may be purchased at electronics supply stores. Install the display in the desired location and connect the ethernet cable to the display.

Remove the electronics cover on the Whisper Controller. If necessary, knock out one of the sheet metal plugs in the Whisper Controller base unit and route the ethernet cable inside the unit. Plug the ethernet cable into the jack in the lower right corner of the controller board. Leave the cover off until the display function is verified.

LCD Display Function Verification

Once the display is plugged into the controller base and the batteries are connected to the controller there should be text displayed on the LCD display. If the display is blank there is a contrast adjusting potentiometer that can be adjusted to brighten the display. Insert a bladed screwdriver into the hole on the display between the buttons and the LEDs. Turn the potentiometer to adjust the brightness. If a display is still not visible disconnect and reconnect the cable to the display to reset the display. Once display function is verified re-install the electronics cover on the controller base.

Anemometer Connection

The Whisper Controller has been designed to accommodate a Model #40 anemometer, manufactured by NRG. Other equivalent anemometers may work, compare manufacturers specifications.

A terminal block on the circuit board is the connection point for the two anemometer signal wires. The terminal block connections are labeled +/- and the polarity should be observed since some anemometers require specific polarity connections. A ground shield (if applicable) should be connected to the controller's grounding terminal.

Reference the picture below to locate the anemometer terminal block.



Anemometer Terminal Block

To achieve the most meaningful air speed data the anemometer should be mounted on the turbine tower as near as possible to the turbine without entering the turbine's sphere of operation. See the manufacturer's recommended installation instructions.

Controller Operation

Whisper Controller Overview

The Whisper Controller provides all of the necessary functions and displays for safe and productive wind generator operation. It includes interface features for setting the regulation voltage, monitoring the state of the system, and manually disabling battery charging. The Whisper Controller interface mechanisms include the LED Display, the Diversion Switch, and the Voltage Regulation Potentiometer, PCB configuration switches and the LCD display.

The Controller contains all of the Whisper Generators power electronics including rectification and load diversion. Additionally, it continuously monitors voltage, current, energy production, and wind speed (optional). These parameters are measured to ascertain system parameters (i.e. battery voltage) and turbine state (i.e. whether power is being generated).

The LCD Display is an interface to the many operational parameters and system measurements of which the Controller is capable. The display may be mounted at the Controller or in a remote location or (with two Displays) both places. From the Display, instant and easy access is gained to voltage, current, power, energy, charge, peak power, and wind speed (with optional anemometer).



Diversion Switch

The diversion switch is located on the top of the controller to the left of the LEDs. Setting the switch to "OFF" causes the power produced by the generator to be diverted the Diversion Load. The Diversion Load is located with the controller enclosure for Whisper 100 and 200's. Whisper 500's have an external Diversion Load.

Note:

- **The switch may not stop a rapidly spinning wind generator, however, once stopped setting the switch to "OFF" will keep the generator from spinning in most winds.**

LED Operation

Steady illumination of the Green LED indicates that batteries are being charged by the wind generator.

Steady illumination of the Red LED indicates that all available power produced by the wind generator is being diverted to the Diversion Load as a result of operator request. The operator may select this mode by setting the Diversion Switch to "OFF" or through the LCD Display.

A blinking Red LED indicates power is being diverted to the diversion load in order to regulate the battery voltage. The table below summarizes the operational state of the controller indicated by the LED's.

LED INDICATORS		
RED LED	GREEN LED	INTERPRETATION
OFF	ON	BATTERY CHARGING
BLINKING	OFF	POWER TO DIVERSION LOAD TO REGULATE BATTERY VOLTAGE
ON	OFF	POWER TO DIVERSION LOAD BY OPERATOR REQUEST— DIVESION SWITCH OR DISPLAY

Setting Regulation Voltage (without Display)

The battery voltage at which the Whisper Controller determines the batteries are fully charged and begins to divert power to the Diversion Load is called the Regulation-On Voltage. This point may be altered by adjusting the potentiometer on the controller's circuit board. See Section 5 on the Whisper Controller PCB. The table below presents approximate information regarding the potentiometer position and Regulation Set Points. If changing the potentiometer position count the number and direction of turns so it is possible to return to the original position.

When the controller measures battery voltage above the Regulation-On Voltage it does not immediately divert power to the Diversion Load. There is a delay of approximately 30-40 seconds, refer to the section on configuring the controller printer circuit board for additional information.

The voltage at which the controller resumes charging the batteries is refer to at the Regulation-Off voltage. If the controller senses battery voltage below the Regulation-Off Voltage for approximately 30-40 second will stop diverting power and start charging the battery again.

Before adjusting the Voltage Regulation-On set-point understand that increasing the voltage will not increase the turbine's output voltage or current. This set-point only adjusts the "shut down" voltage for battery charging. Overcharging will significantly reduce a battery's life expectancy.

Potentiometer Position	Regulation Off Voltage				Regulation On Voltage			
Full Turn CCW	12.0V	24.0v	36.0v	48.0v	13.0V	26.0v	39.0v	52.0v
4 Turns CCW	13.0V	26.0v	39.0v	52.0v	14.0V	28.0v	42.0v	56.0v
Factory Preset	13.4V	26.8v	40.2v	53.6v	14.4V	28.8v	43.2v	57.6v
9 Turns CW	14.0V	28.0v	42.0v	56.0v	15.0V	30.0v	45.0v	60.0v
13 Turns CW	14.0V	28.0v	42.0v	56.0v	16.0V	32.0v	48.0v	64.0v
Full Turn CW	14.0V	28.0v	42.0v	56.0v	17.0V	34.0v	51.0v	68.0v

LCD Display Operation

Operational Overview

The LCD Display adds a tremendous set of features to your wind generator system. Controller measurements can be monitored and operational parameters can be adjusted. Take the time to learn about your Whisper Controller Display to take advantage of its many features.

LED Display

Like the Controller itself, the LCD display has a Red and a Green LED and they function in exactly the same way.

Refer to the Section 7 for detailed information. Due to controller lag time, there may be a delay in updating one set of LEDs. Therefore, it is recommended that if the Display is mounted in the lid of the Controller, that the Display be plugged into the Controller board jack in the lower right corner of the Controller board. This will automatically disable the Display's LEDs. The Controller board jack closest to the Diversion switch should be used for a remotely mounted display.

LCD Contrast Potentiometer

The contrast potentiometer can be accessed through the cover of the Display unit via a hole situated between the buttons and the LEDs. The pot is optimized at the factory for room temperature operation; however, deviations from room temperature can cause the LCD to appear too dark or too light. Carefully insert a screwdriver through the display lid and turn the potentiometer counter-clockwise to increase the darkness of the LCD.

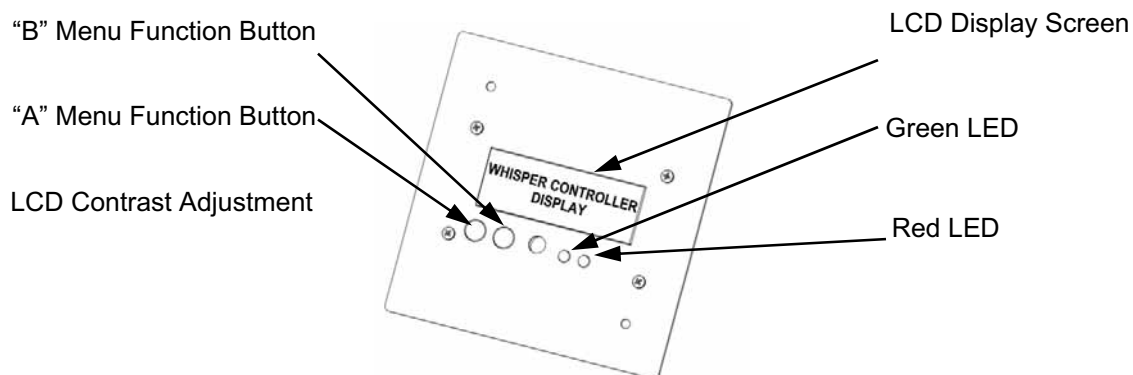

Functions Available Through the Display

Functions available through the display are accessed using two Menu Function Buttons—the "A" button and "B" button. See the figure above. Depressing one of the buttons selects another "Menu Page" according to the Page Structure Chart on Page 21. For example depressing the "A" Button from the "Main" Page causes selection of the "Energy Page". Depressing the "A" Button a second time causes selection of the "History Page".

Refer to the Menu Chart and Menu Navigation "Map" on the following pages to see all the Menu Pages and information available for display. The following sections present detailed information about the information and functions available on each page.

Note that each of the menu pages in this is an access point for various controller and display settings. The "A" and "B" buttons scroll between the menu pages, or change parameters on the menu, or sub-pages. The Reference Numbers in the following paragraph headings refer to Ref # column in the following chart.

Main Page (1)

When first connected, the Display begins with the Main Page. The Main Page displays all of the Controller's measured parameters, including battery charging status, windspeed, charging voltage, battery charge current, and turbine power.

There are four sub-pages associated with this page. From the Main Display the "A" Function button moves through the Energy and History menu pages. From the Main Display the "B" Function button moves through the Mode and Regulation menu pages.

Energy Page (2)

Displayed on the Energy page is the accumulated kilowatt-hours and kiloamp-hours since the last reset.

These can be reset from the reset sub-menu. The leftmost numbers are reset at the factory.

From the Energy page the "A" menu button will go to the History page. The "B" menu button will go to the Energy Reset page.

History Page (3)

Displayed on this page are the average and peak windspeed and turbine power since the last reset. Windspeed is only available if the optional anemometer is installed. Both of these readings can be reset via the reset menu. From the History page the "A" menu button will go to the Main Display page. The "B" menu button will go to the History Reset page.

Mode Page (4)

This page displays the current charge mode. When "ON" is displayed the batteries are being charged, provided that adequate windspeed is turning the turbine. This mode allows the turbine to turn all of the time unless regulating battery voltage or disabled with the Diversion Switch or from this Mode page. When "OFF" is displayed any power being produced by the turbine is diverted to the dumpload by the controller. The "OFF" mode will brake the turbine and prevent it from turning in light winds.

The Controller can switch to "OFF" (Stop) mode in any of the following three conditions:

"OFF_REM" indicates turbine power is diverted to the dumpload due to a request from the Remote Display.

"OFF_MAN" indicates turbine power is diverted to the dumpload due to a request from the Diversion Switch being placed in the "Stop" position.

"OFF_REG" indicates turbine power is diverted to the dumpload due to automatic regulation at the prescribed voltage.

NOTE: The Diversion Switch set to "OFF" (Stop) manually overrides the Remote Display "ON" function.

The mode can be toggled using the "A" menu button. The "B" menu button will go to the Regulation Set page.

Regulation Set Page (5)

Once the Whisper Controller Display is hooked to a Controller, the Controller no longer looks to its potentiometer for setting the regulation voltage. Instead, the regulation on and off voltages are set digitally at the Regulation Page. This page displays a menu allowing change to the Regulation On and Regulation Off set voltages. Selecting "change" using the "A" menu button will bring up a sub-page allowing the Regulation On voltage to be changed. Pressing the "B" menu button will increase the voltage to a maximum of 17.0v and will then roll back to 13.0v. Pressing the "A" menu button will go to the Regulation Off voltage sub-page. Pressing the "B" menu button will again increase the voltage to a maximum of one voltage setting lower than the Regulation On voltage and will then roll back to 12.0v. Pressing the "A" menu button will return back to the Regulation Set page. Pressing the "B" menu button from this page will return to the Main Display page.

Clearly the Regulation Off voltage cannot be specified above the Regulation On voltage.

Display Menu Functions

Ref #	Page	Display			Menu Select	Effect
1	Main	On or Off		00.0 mph	"A"	go to A ring
		11.3V	00.0A	000W	"B"	go to B ring
A Ring						
2	Energy	KWh	0000	000.00	"B"	go to reset menu
		kAh	0000	000.00		
	Reset Menu	Reset kWh?	A: RESET	B: CANCEL	"A"	reset power
					"B"	return to reset menu
3	History	Mph:	00.0a	00.0p	"B"	go to reset menu
		pow:	00.0a	00.0p		
	Reset Menu	Reset Page?	A: RESET	B: CANCEL	"A"	reset readings
					"B"	return to reset menu
B Ring						
4	Mode	Mode:	On		"A"	batteries charging
		A: OFF_REM	B: SKIP		"B"	go to regulation set menu
		Mode:	Off		"A"	batteries diverted
		A: ON_REM	B: SKIP		"B"	go to regulation set menu
5	Regulation Set	REGULATION SET:			"A"	change regulation point
		A: CHANGE	B: SKIP		"B"	return to Main Menu
	Regulation On	Regulation ON voltage:			"A"	go to regulation off menu
		15.8v			"B"	Increase ON set voltage
	Regulation Off	Regulation OFF voltage:			"A"	go to regulation set menu
		12.8V			"B"	Increase OFF set voltage

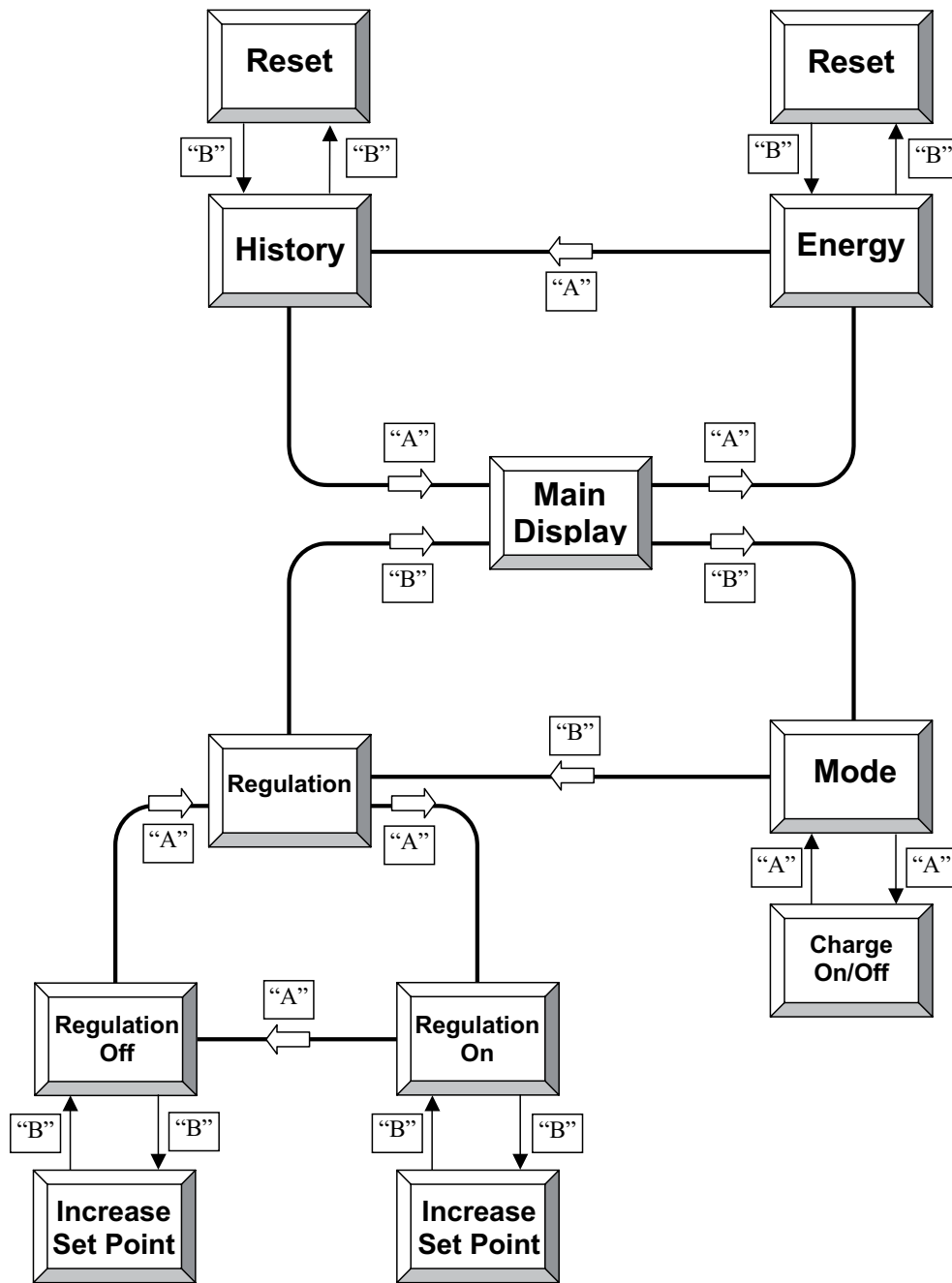

Display Menu Ring Structure

6. MAINTENANCE

Monthly Maintenance

1. TEST BRAKE

(This checks electrical wiring.)

STOP THE WIND GENERATOR IN A MODERATE WIND (CHARGING BUT NOT FURLING) No unusual difficulty or noise should be experienced in stopping the propeller. A noise during braking can indicate a disconnected wire.

NOTE: If the propeller does not stop within 15 seconds of activating the brake, then turn it back “on”, and try again later when there is less wind. Attempting to stop the turbine in high winds can damage the alternator.

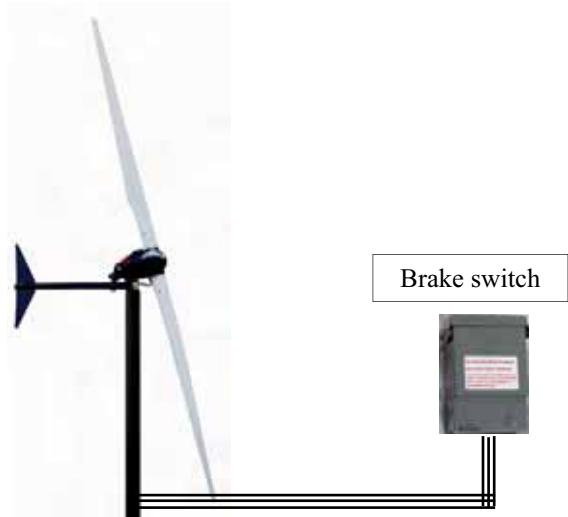

2. CHECK MECHANICAL CONDITION

WATCH AND LISTEN FROM THE TOWER BASE. Use binoculars. There should be no mechanical noise, rattle or vibration. The propeller and tail must not wobble. Lower or climb the tower for inspection, if indicated. There should be no buzzing either heard or felt with your hand on the tower mast. Go to Electrical Problems, if indicated.



3. INSPECT THE TOWER

Follow all inspection and maintenance requirements of the tower manufacturer. Tighten all nuts and bolts, especially wire clips, but do not over-tighten. Check for cracks and bent or broken parts at the anchors and base structure. Check for broken strands and tighten guys.

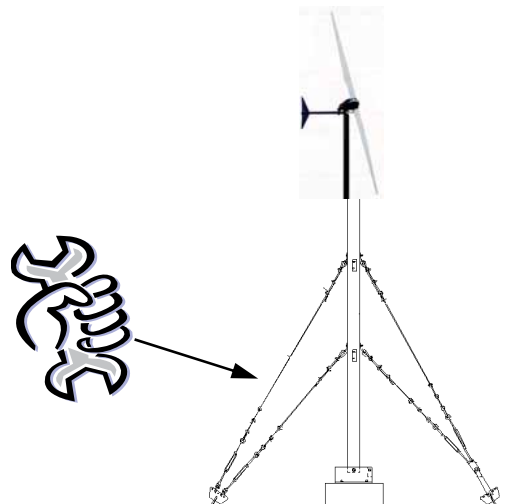

Annual Maintenance

1. CHECK THE BATTERY

Check with battery manufacturer for care and maintenance

- Add only distilled water if low.
- Tighten battery connections
- Remove corrosion and protect terminals
- Wipe tops with baking soda solution.

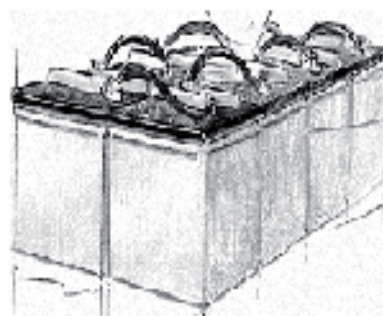

2. COMPLETE MECHANICAL CHECK

- A) Gain access to turbine and give the turbine a complete mechanical check. Fix or replace any worn or loose parts.
- B) Check tightness of all tower mounting nuts and bolts and propeller mounting bolts.
- C) Check all bearings. Just perceptible play is acceptable.
- D) Clean the propeller with mild scrubbing agent to remove all insect deposits. Replace missing leading edge tape. Fill small surface cracks on fiberglass blades (white) with silicone sealant. Repair or replace all white fiberglass blades if either cracked or damaged. Rebalance the blade after modification.

Clean blade and replace missing blade tape on the leading edge

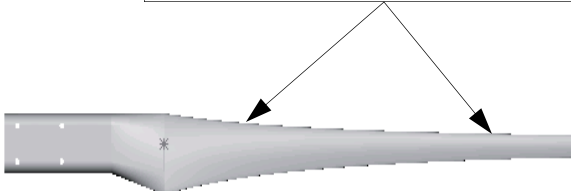

Maintenance Log

Observe Monthly and Annual Inspection Requirements! Record ALL maintenance and repair work!

Date	Problem/Observation	Action Taken

Troubleshooting

WIND GENERATOR SYSTEM

Refer to the following two trouble shooting charts. Determine if the problem is mechanical or electrical. If mechanical see table, **Symptoms of Mechanical Problems**.

Electrical problems can be in the generator or the Whisper Controller. Determine which as follows:

a) Wind generator will not start (blades turn slowly as if the brake is on): On a day of moderate wind, disconnect the three wires from the wind generator one at a time at the Whisper Controller. If the wind generator starts, the wire that allowed it to start leads to a bad diode in the Whisper Controller. Replace the diode.

b) Wind generator still does not start. On a day of moderate wind, disconnect any two wires. If the wind generator starts, the problem is in the Whisper Controller and contact Southwest Windpower. If the wind generator still does not start the problem is in the tower wiring or the wind generator. Go to Table: Symptoms of Electrical Problems.

c) Wind generator is running, but may have an electrical problem. See TEST FIXTURE below.



Propeller does not turn = Mechanical Problem
See Table: Symptoms of Mechanical Problems

Propeller turns slowly = Electrical Problem
See Table: Symptoms of Electrical Problems

TEST FIXTURE

In *moderate* winds, read the phase-to-phase AC voltage between each of the three phases from the wind generator with a multimeter. When the blades are spinning at a constant rpm, there should be a balanced reading of the AC voltage readings for each of the three readings.

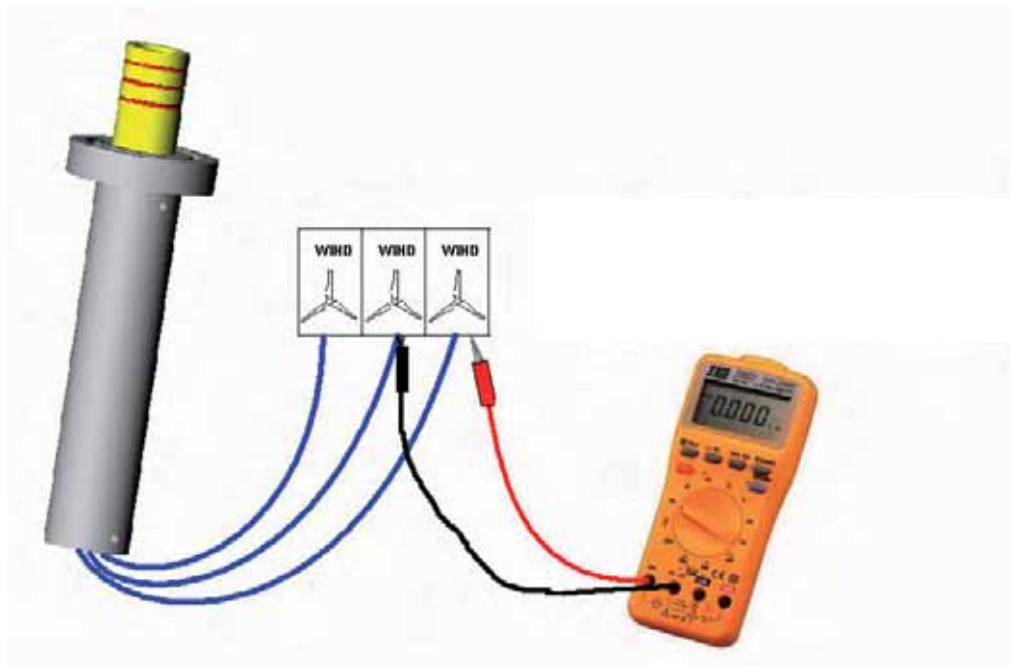

TABLE: SYMPTOMS OF MECHANICAL PROBLEMS

Symptom	Possible Cause	Correction
1. Propeller is stationary, even in high winds	<ul style="list-style-type: none"> a. Ice in generator, or uneven ice on propeller b. Debris between rotor and stator c. Loose or high magnet d. Bad bearing 	<ul style="list-style-type: none"> i. Wait for warm weather i. Turn propeller gently by hand and blow or use piece of paper to dislodge debris i. Remove rotor and re-glue magnet i. Replace bearing
2. Propeller will not turn at all except in high wind, scraping or rubbing sound at low rpm, always stops at same propeller position	<ul style="list-style-type: none"> a. Same as above, except more likely to be high magnet or bad bearing. b. Swelled wire keepers due to high moisture 	<ul style="list-style-type: none"> i. Same as above i. Contact factory. Stator needs re-varnishing.
3. Propeller is harder starting, output is lower & there is more propeller noise than usual. Seems out of balance.	<ul style="list-style-type: none"> a. Ice on propeller b. Dirty propeller c. Eroded leading edge or damaged leading edge tape d. Split, warped or damaged prop e. one or more blades on backwards 	<ul style="list-style-type: none"> i. Prop will eventually shed ice, leave running unless excess vibration i. Clean with soap or bug cleaner i. Refinish prop and replace tape i. Replace or repair propeller i. See blade installation
4. Propeller turns a little, never starts	<ul style="list-style-type: none"> a. Blades on backwards. (See blade installation) 	<ul style="list-style-type: none"> i. Turn blades over. Leading edge advances clockwise from upwind view.
5. Tail, generator and tower vibrate or shake at all or some wind speeds	<ul style="list-style-type: none"> a. Propeller out of balance b. Propeller not tracking c. Rotor (magnet can) out of balance d. blade plate out of balance 	<ul style="list-style-type: none"> i. Balance or replace propeller i. Replace mounting plate ii. Shim at mounting bolts iii. Replace propeller i. Send to factory or balancing shop i. Send to factory or balancing shop
6. Rattle or clunking from generator	<ul style="list-style-type: none"> a. Generator loose in tower b. Loose rotor (magnet can) on shaft loose tail, missing rubber bumper, wires slapping inside of tower, governor pivot bolt loose c. Worn bearings d. Shaft (spindle) broken 	<ul style="list-style-type: none"> i. Retighten mounting hardware, use lock tight or equivalent i. Repair as required i. Replace bearings i. Replace shaft (spindle)

TABLE: SYMPTOMS OF ELECTRICAL PROBLEMS		
Symptom	Possible Cause	Correction
1. Propeller turns slowly even in strong wind, but will not start	<ul style="list-style-type: none"> a. WIND switch is OFF (brake on) b. Battery is dead (voltage less than (1/2 nominal)) c. Incorrect generator wiring d. Short circuit in wiring from generator to Whisper Controller (in tower) e. Shorted diode in Whisper Controller f. Short circuit in brush card or slip ring assembly g. Short in generator 	<ul style="list-style-type: none"> i. Turn WIND switch ON i. Charge batteries with external generator i. Rewire to match battery voltage i. See Installation Step #15 i. See "TEST FIXTURE" / "WIND GENERATOR SYSTEM" i. See "BRUSHES AND BRUSH HOLDERS" i. Rewind
2. Propeller runs too fast, may whistle, no output, no unusual mechanical noise	<ul style="list-style-type: none"> a. Load disconnected b. Two or three wires open between generator and Whisper Controller. c. Whisper Controller diodes open or wire is disconnected at diode terminal 	<ul style="list-style-type: none"> i. Check battery fuse and all connections. i. See "TEST FIXTURE" i. See "TEST FIXTURE"
3. Propeller runs too fast, may whistle, no unusual mechanical noise	<ul style="list-style-type: none"> a. Battery voltage over 50% high b. Incorrect generator connection 	<ul style="list-style-type: none"> i. Battery too small ii. Battery out of water iii. Bad, corroded battery connections iv. Battery worn out i. Rewire
4. Propeller runs too fast, may whistle, output less than 50% for wind speed, growling, buzzing or vibration felt by hand or mast	<ul style="list-style-type: none"> a. Disconnected wire between the generator and the Whisper Controller b. One open or disconnected diode c. One slip ring or brush not making good connection. d. Incorrect generator wiring 	<ul style="list-style-type: none"> i. See "TEST FIXTURE" i. See "TEST FIXTURE" i. See "BRUSHES AND BRUSH HOLDERS" i. See "WIND GENERATOR ELECTRICAL CONNECTIONS"
5. Propeller runs too slowly, output low, no unusual mechanical noise	<ul style="list-style-type: none"> a. Battery voltage low, or a dead battery. b. Incorrect generator wiring 	<ul style="list-style-type: none"> i. Disconnect loads and let battery charge. i. See "WIND GENERATOR ELECTRICAL CONNECTIONS"

Mechanical Repairs and Parts Replacement

CHANGING THE SYSTEM BATTERY VOLTAGE

You must complete all of the steps below to change the system voltage

1. Change the wind generator connection voltage (see figures below)
2. Change the transformer voltage (HVLV models only, see next page)
3. Change the Whisper Controller voltage (see Whisper Controller Owners Manual)
4. Change diversion load configuration (see page 7)

1. WIND GENERATOR ELECTRICAL CONNECTIONS

CHANGING WIND GENERATOR VOLTAGE *(refer to figures for your model and voltage)*

-Typical on all standard models. Black dots indicate connection by plastic wire nut or copper split bolt. These connections are made inside the plastic junction box near the alternator.

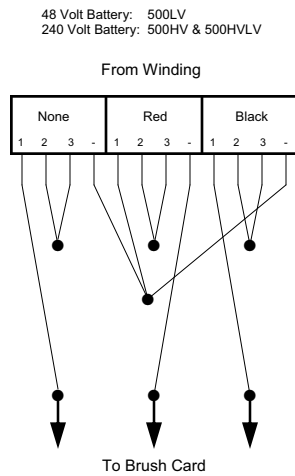
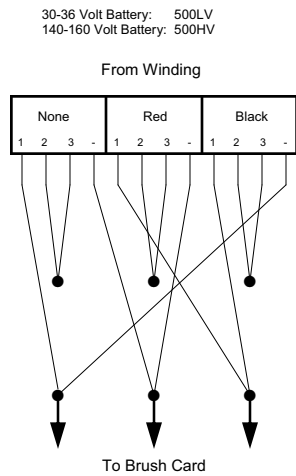
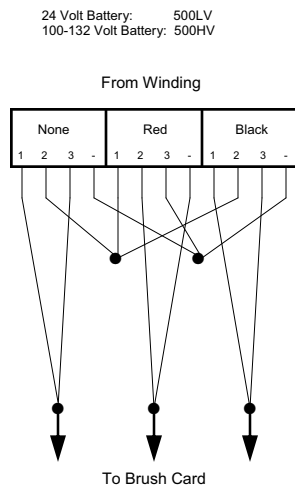
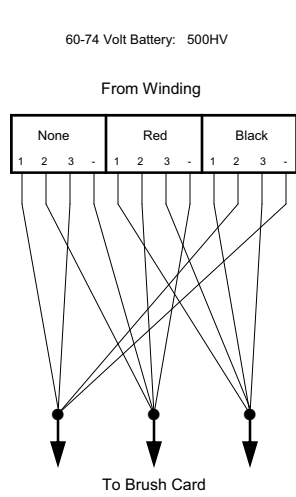

BRUSHES AND BRUSH HOLDERS

Disconnect the wiring harness in the wiring box, disconnect cord grip nuts and remove the lower frame cord grip body. Remove the four screws retaining the brush card and pull the card and attached wiring harness away from its opening.

Check slip rings which should be dark colored and not pitted. Check for continuity and shorts to ground. Clean with mineral spirits and sand lightly to remove pitting or fretting. Yaw bearings should be smooth with just perceptible play.

Brushes are copper/graphite pads soldered to a beryllium spring and should show 50% or more surface contact. Pads should have a minimum thickness of 1.5mm (1/16in) at the thinnest point and not be pitted or badly scored. Polish pads with fine sandpaper and clean all parts. Mounting screws carry electric power and mating surfaces must be clean and screws tight. Align brushes as shown.

Reassemble in reverse order.

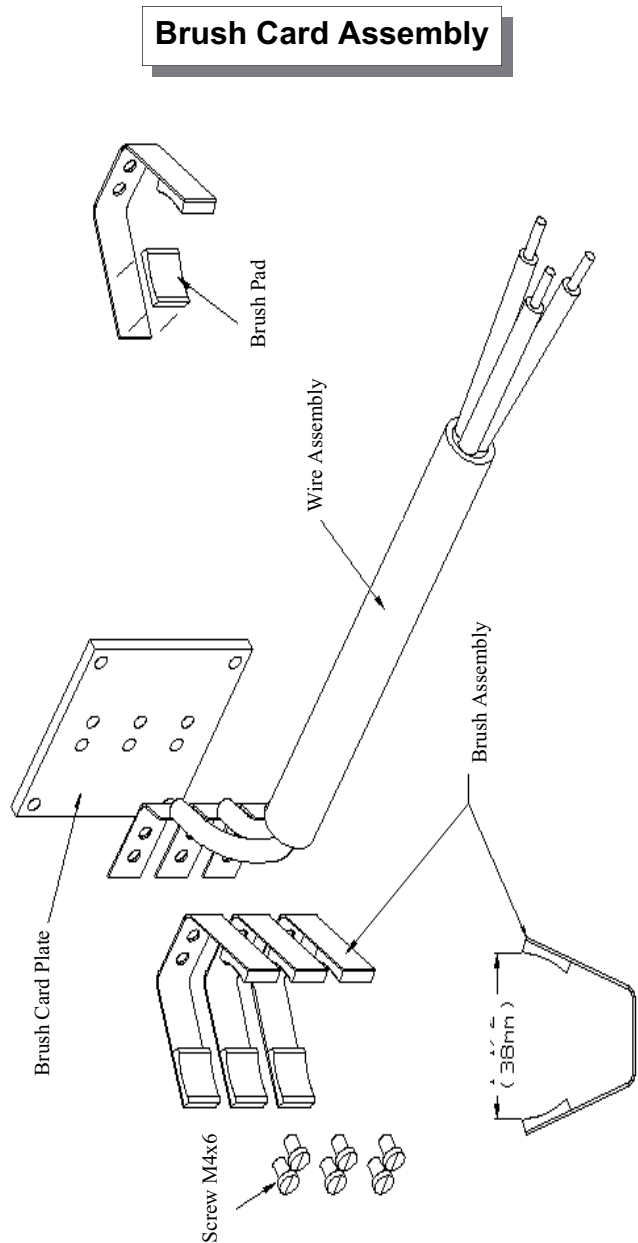

Balancing Blades

1. Set round side of blade on knife edge with leading edge parallel to table. Mark the balance point precisely.
2. Weigh each blade separately (use a grocery store scale) and mark weight on each blade.
3. Cut one (or two) sheet lead weights equal to the difference in weight between the heaviest and the other blade (or blades).
4. Measure the balance point of the heaviest blade from the butt end and mark this BALANCE POINT on the other blade or blades.
5. Place the lighter blade or blades back on the knife edge at the BALANCE POINT of the heavier blade. Locate the balance weight lengthwise until the blade balances. You now have two blades of identical weight and center of gravity (balance point).

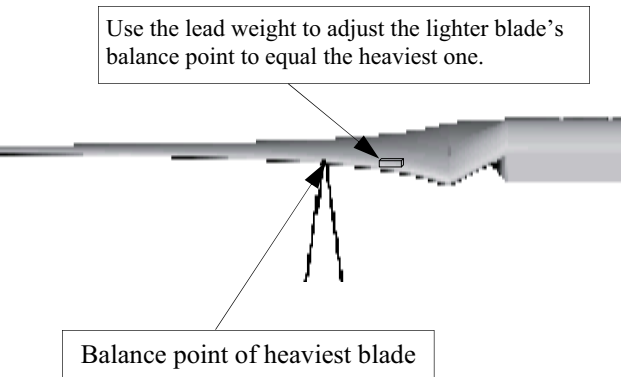
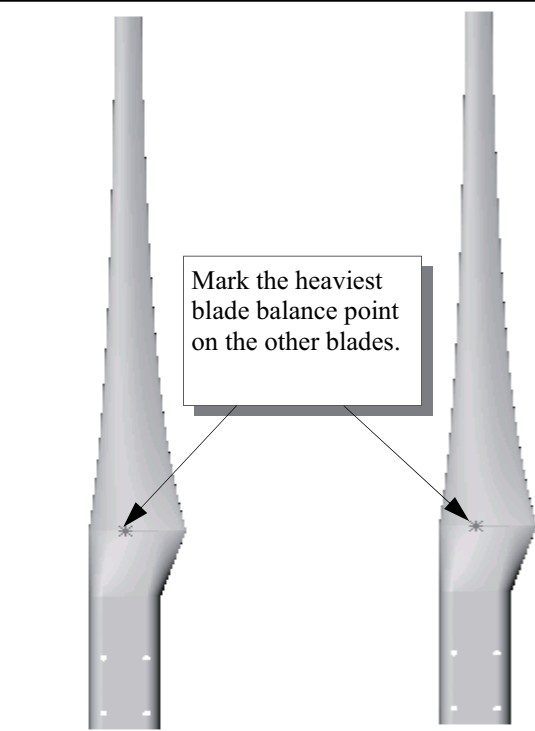
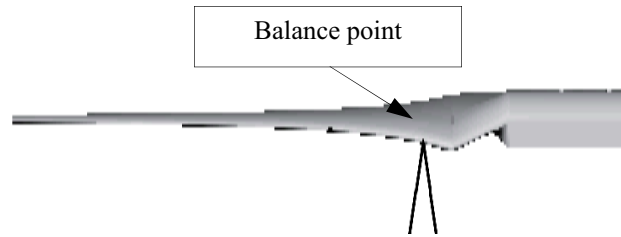

Exploded View Parts List-Whisper 500*Use item # and description when ordering.*

Item	Description	Quantity
1	Rotor	1
2	Spindle	1
3	Stator	1
4	Yaw Housing	1
5	Yaw Shaft	1
6	Brush Card Assembly	1
7	Brush Card Plate	1
8	Wire Box and Gasket	1
9	Spacer	1
10	Hex Head Screw M8x40 CL10.9	6
11	Flat Washer M8x17 TP200	6
12	Retaining Ring 35mm External	2
13	Retaining Ring 72mm Internal	1
15	Bearing 6206-2RS	2
16, 17	Bearing 6207-2RS	4
18	Nylock Nut 7/8-14	1
19	Bolt 7/8-14 x 4 3/4	1
20	Cord Grip 3/4NPT	2
21	Lock Washer M5 SS	2
22	Screw M5 x 16 SS	4
23	Screw M4 x 10 SS	4
24	Screw 8-32 x 1/2 BRASS	1
25	Screw 8-32 x 3/4 BRASS	1
26	Light Amber	1
27	Light Wire	1
29	Blade Plate	1
32	Shock	1
33	Spring	1
34	Shock Spacer	1
35	Light Adapter	1
36	Hex Head Cap Screw	1
37	Nylock Hex Nut 7/16	1
38	Flat Washer 5/8 SS	1
39	Flat Washer 7/16	1

**Whisper 175 Exploded View
Whisper 175 - Vista desagregada**

