

# 5K3-EVO Installation and Operation Manual

## V2.4

*Dual Voltage*

## Warning

### Mandatory Reading of the Entire Manual

Even if you intend to work exclusively with HV or LV batteries, it is essential that you read the entire manual, including both HV and LV sections. Certain procedures are described in greater detail in one section than in the other; therefore, complete reading is necessary to ensure a full understanding of the system's operation, safety measures, and limitations. Failure to review the manual in its entirety may lead to installation errors, improper use, and potential risks to people and property. For correct installation, maintenance, and safe operation of the batteries, always follow all instructions contained in this manual.

## Preface and Disclaimer

Thank you for choosing our product. Our goal is to offer you a high-quality product and reliable after-sales service.

Before purchasing, installing, operating, or maintaining the **5K3-EVO Battery Module**, please read this manual carefully to prevent accidents and protect the product, operators, and users from damage.

This manual contains detailed information on the operation, maintenance, troubleshooting, and safety rules of the product.

### Disclaimer

WECO shall not be liable for any damage, malfunction, or injury resulting from installation, use, or maintenance not in accordance with the instructions contained in this manual, including but not limited to the following:

- Installation or use in environments that do not comply with local regulations.
- Installing, using, or maintaining the battery under conditions inconsistent with those described in the manual.
- Disassembly of the product or modification of software code without permission from WECO.
- Failure to follow the safety instructions in this manual.
- Use of unauthorized or unqualified parts or modules for the system.
- Damage caused by abnormal natural conditions (force majeure, such as lightning, earthquakes, fires, storms, etc.).
- Damage caused by the transport of the product if the shipment has been arranged by the customer, including unloading by the customer.
- Damage due to storage conditions that do not comply with the requirements of the product documentation.
- Hardware damage resulting from customer misuse.

### Capacity and performance notes

The rated capacity of the battery module is **5.22 kWh** with 100% to 0% SOC discharge under the control of the BMS, measured when new and within three (3) months from the date of manufacture, provided that the storage conditions are in accordance with the provisions of this manual.

The capacity is not constant for each cycle and can vary depending on several factors.

The degradation of battery energy is typical of any accumulator and is irreversible, in addition the degradation of a battery is not linear in time and/or cycles and is strongly affected by factors such as temperature, C-Rate and Depth of Discharge (DoD) and frequency of charge and discharge.

Residential models are designed to perform about 1 maximum two cycles per day and the charging and discharging process must normally be spaced out by about 30-40 minutes of waiting in order to allow proper temperature dissipation and limit thermal degradation

The **Limited Performance Warranty document** defines the parameters to get the best performance out of the battery.

### Intellectual Property Rights Notice

All trademarks mentioned in this manual are the property of their respective owners. Any third-party trademarks, product names, trade names, company names, and company names mentioned are trademarks or registered trademarks of other companies, used solely for descriptive purposes and in the interest of the present manual and interactions with it, without any intent to violate copyright laws.

### The following are strictly prohibited:

- Reverse engineering or decompiling the battery software.
- Removing or replacing the BMS
- Turn around BMS protection functions to achieve performance or to bypass safety actions or BMS lock
- Deletion of historical data and BMS alarms
- Repairs not authorized by WeCo
- Fraudulently obtaining the source code or functions of the software software to change its battery thresholds and/or limits  
*Product specifications may be changed without notice*



## ATTENTION



THIS MANUAL MUST BE READ IN ITS ENTIRETY EVEN IF YOU ARE USING THE 5K3 EVO BATTERY IN A HIGH VOLTAGE CONFIGURATION. YOU MUST ALSO READ THE LOW VOLTAGE SECTION.



WARNING: The battery may explode and/or catch fire if subjected to strong impacts or punctures and/or if used outside of operating conditions.  
WARNING: Use suitable lifting systems to install the battery, as it weighs over 50 kg. The use of mechanical systems is required.



WARNING: The battery may explode or catch fire if exposed to flames, sparks, and/or heat. The technical room must be suitable for the type of battery and must be equipped with appropriate safety systems.



ATTENZIONE: Verificare che la tensione sui terminali Basso Voltaggio sia 0Vdc prima di operare sui terminali.  
ATTENZIONE: I terminali Alto Voltaggio (Connettori fast WECO 150A) non hanno interruzione di circuito.



CAUTION: The battery may accumulate stray currents. After switching off, always wait at least 5 minutes before working on the terminals. Ensure that the voltage on the low voltage terminals is always 0Vdc.

The high voltage terminals must always be protected by the rubber covers provided during operation and must only be removed immediately before connecting the HV cable.



CAUTION: Always use mandatory PPE when working on the battery.



At the end of its life, this battery must be recycled in accordance with current regulations.

Contact your nearest COBAT center to arrange delivery of your end-of-life product. The product must be delivered by a company that meets the legal requirements, and the customer is always responsible for the cost of return delivery.



**Do not open the battery cover for any reason.**

**Opening the battery is prohibited and potentially dangerous.**

**Do not short-circuit the battery terminals as this may cause fire or explosion.**

**Do not use charging devices, cables, connectors, fuses, or switches that are not approved by WeCo.**

**The battery and its connections, such as cables, switches, fuses, bars, etc., must be inspected, cleaned, and tightened every three months or when necessary, taking into account the environmental conditions and/or stress of use of the system.**

**Cables and insulators may experience an early reduction in their insulation coefficient if exposed to excessive environmental conditions and stress during use. Therefore, it is necessary to verify the safety of the system through regular checks, which must be defined by the designer during the design phase.**

**WeCo declines all responsibility for illegal or unauthorized actions on the battery.**

## IMPORTANT SAFETY NOTICE

### System Lock Condition

The battery is equipped with an automatic protection function that stops operation in case of out-of-specification parameters. In this condition, the system opens the power circuit (technical block).

- The status LED and LED bar will show alternating red light with other operating statuses.
- In this condition, the battery cannot be used and must be isolated from the rest of the system.
- Restoration of operation may only be carried out by qualified personnel and after verification of the operating parameters.
- An unauthorized or unverified restart attempt on the BMS and inverter may cause risk to people and property, as well as void the warranty.

### Safety disclaimer — Abuse / out-of-spec use

If a 5K3 EVO battery has been abused, over-discharged, over-charged, damaged, tampered with, or operated outside the limits in this manual, **stop using it immediately**. Isolate it on a non-combustible surface in a ventilated area, keep people away, and **contact an authorized installer** to handle, inspect, and—if necessary—dispose of it under local regulations. **Do not attempt to charge or “revive”** any pack or cell at extreme under-voltage; recharging LFP from deep low voltage can cause irreversible damage, venting, or fire. **Do not reuse, repair, or harvest parts** from a damaged pack. Use contrary to these instructions **voids the warranty** and releases the manufacturer from liability.

## Prohibitions

Do not attempt reuse, repair, reconditioning, or recycling of cells/parts from a battery that has been abused, damaged, or driven into extreme under-voltage, do not remove change BMS or exchange and or reuse parts or an out of spec used battery.

Do not attempt “forced charging” or jump-starting of a battery whose pack voltage or any cell voltage is below the minimum allowable limits specified for the product.

Recharging a lithium-iron-phosphate (LFP) battery from an extreme low-voltage state can cause irreversible internal damage and presents serious safety risks (internal shorting, gas generation, thermal runaway, smoke/fire).

**Do not open, disassemble, or bypass the BMS. No user-serviceable parts inside.**

Do not transport a damaged/abused battery except if conducted by a qualified professional and in compliance with dangerous-goods rules.



### **CAUTION CRITICAL RELEASE FIRMWARE INSTALLATION REQUIREMENT MANDATORY FIRMWARE UPDATES (CONDITION OF SALE)**

By purchasing, installing, commissioning, or using this product, you acknowledge and agree that ongoing firmware updates released by WeCo are required to maintain safety, regulatory compliance, interoperability, and performance.

“Critical Update” means any firmware that WeCo designates as addressing safety, compliance, battery protection, reliability, or material performance improvements.

You must install or delegate others to install on your behalf any Critical Update within 60 (sixty) calendar days of WeCo’s notice; failure to do so may void warranty coverage for related faults and constitutes misuse/non-compliant operation under the Limited Warranty.

The batteries include integrated Bluetooth® and Wi-Fi hardware; firmware can be updated directly from a phone via the Bluetooth app without the need of a local Wi-Fi network, just a mobile phone is needed.

If you are unable to complete an update, you must promptly contact WeCo for support. During the transitional period before a required Critical Update is applied, it is advisable to switch the battery OFF and keep it out of service in accordance with site safety and lock-out/tag-out procedures.

The installation or use of unauthorized or modified firmware is prohibited and voids the warranty.

This update requirement forms part of the product’s operating conditions and the condition of sale and use.

Nothing in this disclaimer limits any non-excludable rights you may have under applicable consumer law. For full details, including consequences of non-installation, refer to the Limited Warranty.

To benefit from the 10-year performance warranty, the battery must remain continuously online via the WeCo app throughout the warranty period. Offline cumulative allowance is allowed for up to 60 days per year.

If a claim occurs while the unit is offline and the required telemetry/logs are not available on either the cloud or the BMS, WeCo may reject the claim for lack of evidence, according to the Limited Warranty.

Make sure your battery is constantly online, this will ensure you get the latest FW update, remote control and full coverage for the extended performance warranty



### **WARNING**

This battery module is primarily designed for use in indoor or weather-sheltered, temperature-controlled environments. Installation in outdoor conditions is allowed if it complies with all environmental limits, protection ratings, and installation guidelines defined in this manual.

The use with low voltage inverters and/or bus bars on low voltage terminals without the specific accessory does not allow installation in environments not protected from water and humidity as the low voltage terminals are not IP65 insulated.

Only with the rubber cover accessory are the low-voltage terminals classified as IP65, meaning that the battery can be installed in environments that comply with this specification.

**DO NOT OPEN THE BATTERY COVERS. DO NOT REPAIR OR DISASSEMBLE ANY PART OF THE BATTERY.  
DO NOT OPEN THE BATTERY COVER AND/OR REMOVE THE WARRANTY SEALS.**

## Declaration

The information and guidance in this manual refers to the WECO stackable battery model 5K3EVO. This manual contains two sections:

**Section 2 covers LOW VOLTAGE APPLICATION \* Often referred to as LV**

**Section 3 covers the HIGH VOLTAGE APPLICATION\* Often referred to as HV**

In the event of product updates or other reasons, this document will be adjusted accordingly without prior notice or publicity, it will be made available on the WECO website in the download section.

Unless otherwise agreed, this document is to be used as a guide only and never supersedes the Laws of your State. All statements, information and advice in the documentation do not constitute any express or implied action that contradicts local regulations or standards.

For further information or clarification, please contact us before installing the product.

Official information and the latest data sheet can be found on [www.wecobatteries.com](http://www.wecobatteries.com).

It is essential that the battery module is equipped with the latest firmware version available. New batteries are always shipped with the latest firmware version available at the time.

From time to time, the firmware will be updated to improve the functionality and performance of the battery.

Firmware is always available on the [www.wecobatteries.com/download-area website](http://www.wecobatteries.com/download-area-website). Check the website or monitor the APP, in case of critical update will be sent to WeCo customers by e-mail.

The latest firmware version is always available for free and can be updated by your local installer. You can always contact [service@wecobatteries.com](mailto:service@wecobatteries.com) for more information on the upgrade process.

## Information requirements, document delivery, and maintenance

### 1) User training and information (mandatory)

The installer must train and inform the end user before leaving the site. Training must include, at a minimum:

safety, commissioning/shutdown, normal use, alarms/faults, operating limits, scheduled maintenance, and service contacts.

### 2) Delivery of documents and settings

Before leaving the site, the installer must deliver to the user and explain:

- current user and maintenance manual,
- quick guide/safety data sheets,
- system configurations and settings actually applied (reports or screen prints),
- relevant certifications/reports (tests, inspections, LOTO, PE measurements),
- scheduled maintenance plan (frequency, activities, responsibilities).

Delivery and training must be confirmed by a report signed by the user. In the absence of such a report, the system is considered not delivered and the installer must not leave the site and/or must render the system inoperable if, due to unforeseen circumstances, they must leave the site.

### 3) Scheduled maintenance and after-sales service

It is the installer's responsibility to inform the customer in writing of the need to carry out scheduled maintenance (safety, integrity of connections/bus bars, firmware, cleaning, periodic checks) and to propose an after-sales contract for the management of these activities (SLA, spare parts, reporting).

### 4) Customer rejection and assumption of risk

If the customer refuses the maintenance contract or fails to carry out the prescribed activities, he/she assumes full responsibility for any malfunctions and possible damage to persons and/or property resulting from failure to perform maintenance or improper maintenance. In such cases:

- The installer shall not be held liable for any malfunctions, deterioration, or system downtime attributable to lack of maintenance.
- Any warranties may be void, to the extent permitted by law and the manufacturer's warranty terms.

All products must undergo periodic inspections and must be checked in accordance with the instructions in this manual.

Ten years after the date of manufacture, the customer must initiate the battery disposal procedure in accordance with the regulations of their country.

### 5) Traceability and evidence

The installer must keep a copy of the delivery/training report, the maintenance plan provided, the settings applied, and the measurements/tests performed (with date, time, signature, names).

#### Delivery checklist (to be completed/signed)

- User manual and maintenance manual delivered and explained to the user of the equipment
- MSDS safety data sheets delivered
- System settings explained to the customer
- Scheduled maintenance plan explained and proposed
- Support contacts and escalation procedures provided
- Training provided on: safety, start-up/shutdown, alarms, usage limits
- Report signed by the customer

# "Acknowledgment and acceptance of the end user" module

## Compilation by the installer

I, the undersigned \_\_\_\_\_, as user/legal representative and therefore owner of the system, declare that I have received and understood manuals, system settings, maintenance plan and training on the safe use of the system. I undertake to respect the scheduled maintenance plan.

I was offered an after-sales contract for a fee by the installation company

Accepted

Rejected

In the event of refusal or omission of maintenance activities, I assume the risk of malfunctions and possible damage to persons and/or property, without prejudice to the provisions of the law.

Plant address: \_\_\_\_\_

Installed serial reference:

S/N _____	S/N _____	S/N _____
S/N _____	S/N _____	S/N _____
S/N _____	S/N _____	S/N _____
S/N _____	S/N _____	S/N _____
S/N _____	S/N _____	S/N _____
S/N _____	S/N _____	S/N _____
S/N _____	S/N _____	S/N _____
S/N _____	S/N _____	S/N _____
S/N _____	S/N _____	S/N _____
S/N _____	S/N _____	S/N _____
S/N _____	S/N _____	S/N _____
S/N _____	S/N _____	S/N _____
S/N _____	S/N _____	S/N _____
S/N _____	S/N _____	S/N _____
S/N _____	S/N _____	S/N _____

Reference to current standards and laws

Training, document delivery, commissioning and maintenance activities must be carried out in accordance with the laws, regulations and technical standards in force in the country of installation, including (but not limited to) the standards on low voltage electrical systems (IEC/EN 60364 and national transpositions), safety of batteries and storage systems (IEC/EN 62619), requirements of the competent authority and the network distributor, as well as any applicable local directives/regulations.

In the event of a discrepancy, local law shall prevail; The installer is required to adapt the design, execution and documentation and to demonstrate compliance.

The electrical conformity of the system must be renewed within the term provided for by law and with it the regulatory compliance of the systems that are part of the system including batteries, HV BOX Inverter etc. must be verified.

Print the following page and create two originals, one to be kept by the installer and one by the customer

Place: \_\_\_\_\_

Date \_\_\_\_\_ // Client signature \_\_\_\_\_

Date \_\_\_\_\_ // Installer Signature \_\_\_\_\_

## Premise:

Thank you for choosing our product. We will provide you with a high-quality product and reliable after-sales service.

To avoid injury to personnel and damage to the product, please read this manual carefully.

This manual provides detailed information on the operation, maintenance, and troubleshooting of the product, as well as health and safety recommendations.

Some users may not find all the information in this manual sufficient or unclear, therefore, before installing or purchasing WeCo products, they may request a dedicated training course in person or via remote connection.

The Lithium battery installation and maintenance guide is an integral part of the manual and is located on the <https://wecobatteries.com/download-area/> website and should be read before installing the batteries.

The general terms and conditions of sale are available on the website [wecobatteries.com](https://wecobatteries.com) download area, they must be read before purchasing.

## Declaration

The manufacturer reserves the right of final explanation of any contents of this manual.

These batteries cannot be used to power life-saving devices or for UPS or Back-up use to power or support life-saving medical devices.

The battery capacity is intended to be 5.22kWh in the 100-0% range of the BMS.

Capacity is not constant with each cycle and can vary based on many factors, energy degradation is not constant over time or cycles, and is strongly influenced by temperature, C-Rate, and DoD (Depth of Discharge).

The first 500 cycles are typically affected by a greater decrease in capacity than subsequent cycles.

Before purchasing this product please read the warranty terms available on our website.

Always check the latest technical data on our website as it may be changed.

If this manual is not clear to you, do not purchase or install the battery, ask for a technical meeting by writing to

[service@wecobatteries.com](mailto:service@wecobatteries.com).

Limited Performance Warranty Documents set parameters to get the best performance out of the battery based on the standard test condition used by WeCo.

Any additional details about this battery, its BMS and compatibility with inverters can be requested by writing to

[service@wecobatteries.com](mailto:service@wecobatteries.com).

This battery and its accessories are intended to be installed, maintained, and supervised only by experienced and qualified installers.

All trademarks in this manual belong to their legitimate owners; Third party trademarks, product names, trade names, company names and companies mentioned may be trademarks owned by their respective owners or registered trademarks of other companies and are used for explanatory purposes only and for the benefit of the owner, without any purpose of infringing applicable copyright.

The evaluation of the product is an important and necessary phase and must precede the purchase, it is advisable to evaluate the latest technical data sheets made available on the [www.wecobatteries.com](http://www.wecobatteries.com) website or request a copy directly from [sales@wecobatteries.com](mailto:sales@wecobatteries.com).

Our products and manuals are mainly dedicated to installers and technicians who are experts in the sector with specific qualifications for electrical systems.

The manual, the system certification and the "first start-up" test certificate or system conformity, of the entire system carried out according to the national standards of your country, must be given to the end user after adequate training on the use and maintenance of the battery and the system in general.

These batteries are intended to be marketed for integration into more complex systems installed only by professional operators.

After reading the manual in full, we hope you can purchase our products.

Before purchasing, please carefully evaluate the technical characteristics with the data provided on our website or by requesting the updated version of the battery model currently in production.

Pay attention to the distinction between BMS temperatures and the operating temperatures of the battery as a lithium accumulator, i.e. the temperatures to which the BMS can be exposed without being damaged, malfunctioning or being affected in the reading of data such as temperatures voltage current (an incorrect reading of the data for exposure to out-of-range temperatures could affect the control and safety logic).

The lithium battery, on the other hand, should not be exposed to temperatures that are too low or too high, while the temperature excursions of the environment in which they will be installed should remain as constant as possible. Below you will find correct instructions on the use of the battery and the permissible and recommended temperatures.

The technical data sheets may be subject to change due to market or industrial needs, therefore, the technical data sheets present on third-party websites or in any case distributed in the past may not be updated and in any case correct. Get the latest official releases from [sales@wecobatteries.com](mailto:sales@wecobatteries.com).

The pre-purchase evaluation is an important phase and for this reason it must be conducted carefully and perhaps with the help of qualified and experienced technicians if your knowledge on the subject is not sufficient.

WeCo batteries are developed for domestic and industrial applications and can only be installed and maintained by experienced and

qualified personnel, they are not produced for direct sale to private individuals.

ESS (Energy Storage Systems) batteries for domestic applications are designed to maximize the self-consumption of energy from renewable sources. Use for backup systems, or for UPS systems, is possible within the charge/discharge current limits of the ESS.

This manual provides detailed information on the operation, maintenance, and troubleshooting of the product, as well as health and safety advice; the information contained in this manual may not be sufficient to cover specific applications, so, if your specific case is not mentioned, please do not purchase our batteries until every technical and safety aspect of your specific application has been clarified. You can request technical support from [service@wecobatteries.com](mailto:service@wecobatteries.com).

End of life, end of use and disposal

The Product (battery) is designed for a maximum service life of the first of:

- a) 10 (ten) years from the Production Date indicated on the label
- b) 7,000 equivalent charge/discharge cycles (DoD 90% at 25°C and C-rate 0.5C)

Upon reaching the first of the aforementioned limits, the User is required to cease using the battery.

Within a reasonable period of time from reaching the limit (point 1), the User must start the end-of-life management according to the applicable legislation in the country of installation, delivering the battery to the collection systems indicated by the manufacturer or to operators authorised to transport, treat, recycle and/or recover. The instructions and delivery channels are shown on the label/manual and in the official references of the manufacturer. Abandonment or improper disposal is prohibited.

Any overhaul/regeneration of the battery after the limit specified in point 1 has been reached may only be carried out by a qualified and legally authorised third-party company. This company assumes all responsibility for compliance, safety and post-intervention performance.

The original manufacturer does not warrant or assume responsibility for products that are used beyond limits or remanufactured/tampered with without its written permission.

L'uso della batteria oltre il limite di cui al punto 1 o in difformità dalle istruzioni comporta la decadenza da ogni garanzia convenzionale e avviene a esclusivo rischio dell'Utente.

Determining Limit Reach

The achievement of the useful life limits is determined by means of BMS logs and/or other objective technical evidence (diagnostic reports, cycle counters, maintenance logs).

WeCo offers two types of warranty on its products, the warranty on manufacturing defects also known as the European warranty and in addition the warranty on performance, this subject to compliance with installation requirements well defined in the warranty document.

More information can be found in this manual and on the specific warranty document available for each battery model.

## **SYSTEM DESIGN BY EXPERIENCED TECHNICIANS**

Systems Design is the process of defining the architecture, components, modules, interfaces, and load data for a system by the customer in order to meet the specified requirements

For a solar system these components are the PV modules, the inverter/charge controller and the batteries, as well as the different interfaces of these components.

These systems must be integrated with each other following the respective technical rules and must be compatible with each other.

The design must take into account functional guarantees and performance guarantees in order to guarantee the end customer full satisfaction of the product he will use.

For safety reasons, if the battery is not operating at the temperatures, currents and DODs specified in the performance warranty requirements, it should be inspected frequently according to the conditions of use applied.

WeCo bases warranty and safety on the standard conditions of use described above; Heavier uses and at suboptimal temperatures will have direct effects on premature battery aging and intrinsic safety.

With System Design, the designer, based on the prescriptions of this manual and on his own experience, must guarantee some important steps:

**System longevity:** Establishing an appropriate frequency for maintenance and inspections can extend the useful life of the system, preventing premature failures and ensuring that the system operates at optimal levels for as long as possible.

**Safety:** Regular maintenance and inspections help identify and fix potential safety issues before they can cause accidents or malfunctions.

**Operational efficiency:** A well-maintained system tends to operate more efficiently, with fewer interruptions due to failures or malfunctions, thus ensuring better performance and reliability.

**Cost Consideration:** While regular maintenance incurs additional costs, it can actually help reduce overall costs in the long run, preventing costly failures and extending the life of the system.

**Breakdowns and rapid intervention:** in the event of a battery failure and/or alarm, it is mandatory to immediately disconnect the battery from the inverter and keep it off until the technician arrives.

To ensure that these maintenance practices are followed correctly, it is essential that they are well documented and passed on to the end customer or maintenance person. This includes the preparation of a detailed maintenance plan, which specifies the frequency of the various maintenance and inspection activities, based on the characteristics of the site and the application in which the system is installed.

# BATTERY OPERATION

There are several factors that affect the operation of the battery in terms of its ability to provide capacity and life expectancy. If you respect the battery, it will work safely and efficiently for many years.

## Storage

The battery module should be stored in its original packaging, in a clean, level, dry, cool place and indoors.

The recommended storage temperature is 25°C +/-5 (case b.), but different storage ranges are acceptable:

14°F to +32°F / -10°C to +0°C range: Inspection and recharge required every three months, SOC required at 40-60%

32°F to +86°F range / +0°C to +30°C: Inspection and recharging every six months required. SOC required at such ranges 40-70%

86°F to +113°F / +30°C to +45°C range: Inspection and refilling every three months required. SOC required at such ranges 25-30%

NOTE: Maximum charge is 0.2C at an ambient temperature below 11°C and maximum 0.5C in the range of 12°C to 35°C.

The maximum SoC for maritime transport is regulated by the UN directives or by the transport companies, so it may vary over time.

Inspection parameters: Identify the state of charge, search for alarms and act accordingly, look for physical damage to the battery module.

For trickle charging, charging at between 0.1C and 0.2C up to 50%-70% SOC is suggested and then discharging to the SOC limit allowed by local regulations.

SOC suggested 30%~50% if stored in stock.

Do not recharge below +10°C

If shipped by sea, you must refer to the UN38.3 standard; for road, rail or air handling, refer to the local ADR codes or similar.

## Operating Temperature and Thresholds (even outside the thresholds allowed by the performance warranty)

Many chemical reactions are affected by temperature and this is also true for the reaction that occurs in a WeCo storage battery.

The chemical reaction of a lithium ion is slowed down by the lowering of the temperature of the electrolyte contained in the battery, which results in a lower capacity and a higher long-term performance decay index in direct proportion to the departure from the optimal temperature prescribed by WeCo.

A new battery that provides 100% of the rated capacity at 25°C will only provide about 75% of the rated capacity when deployed at 10°C.

At 0°C charging is not normally allowed by the BMS, except for the emergency condition managed by the BMS.

At temperatures below -7°C the BMS will only allow 0.03C of charging current for emergency situations; at temperatures below -10°C, charging is prohibited.

Although it is possible to discharge the battery down to -20°C, it will then be impossible to recharge it as the charging phase is prohibited at 0°C.

These thresholds do not mean that the battery warranty applies even under such conditions, even if allowed by the BMS as extreme values. The logic of the BMS does not coincide with the thresholds to be respected in order to benefit from the performance warranty, as compliance or non-compliance with the latter is up to the end customer, while the limitations inherent in the battery safety thresholds are set by the BMS as factory data.

The warranty conditions (Functional and Performance) are well described in the "Limited Warranty" document and should be read before purchasing the product.

For the performance warranty, WeCo requires that the batteries are installed in a appropriate environment that allows the maintenance of a temperature in the range of +11°C and +35°C, (thermoregulated) that does not allow condensation or humidity formation above 80%, ventilated and healthy.

For example, the functional guarantee (pursuant to European Regulations) prescribes that the installation of batteries with IP20 must be indoors, i.e. indoors, with controlled humidity and temperatures, while the performance warranty prescribes that charging and discharging must be carried out between 11°C and 35°C at 0.5C and DoD 90%; any use outside these requirements is not covered by the performance warranty.

For the warranty against manufacturing defects, higher temperatures are allowed, i.e. +0°C + 40°C, ventilated room and without condensation formation in order not to lose the right to the warranty for manufacturing defects (European warranty).

Most battery capacity/life issues can be traced back to improper charging. Incorrect charging settings can lead to overcharging or undercharging conditions, any incorrect charging process will affect the battery life or its ability to retain power.

The lower the C-Rate of the charge/discharge process, the more the battery will benefit from long-term performance.

## Depth of Discharge (DoD %)

The depth of discharge is a function that is implemented through the setting of the hybrid inverter, compatible with WeCo.

The deeper the discharge, (e.g. DoD 100% means completely discharging the battery), the shorter the battery life over its estimated useful life.

The number of cycles and the DoD specification will affect the expected life in years that the battery/battery system will provide prior to replacement.

To maximize the remaining capacity over the battery's useful life, set the inverter's DoD to 20%, this will help maintain health (SoH) for longer.

The functional warranty indicates the maximum DoD at 100% because both the logic and the hardware of the battery have been verified and tested to achieve it, while the performance guarantee establishes that the maximum value of the DoD % (to be set in the inverter) must not exceed the value of 90% at 25°C 0.5C, without prejudice to the previous requirements.

For safety reasons, if the battery is not operating at the temperatures, currents and DODs specified in the performance warranty requirements, it should be inspected frequently according to the conditions of use applied.

WeCo bases warranty and safety on the standard conditions of use described above, heavier use and at suboptimal temperatures will have direct effects on the premature aging of the battery and with it intrinsic safety.

## C-Rate

The value of the current used to charge and discharge the battery is expressed in C (1C = 100A, 0.1C = 10A in the case of the 5K3-EVO 100Ah battery).

## Charge/Discharge

Most battery capacity/life issues can be traced back to improper charging also due to improper location. Improper charging settings can lead to an overcharge or over-discharge condition or out-of-range current for the temperature condition and SOC%.

WeCo only guarantees batteries connected via CAN/BMS line to the compatible inverter (see compatibility list on the [www.wecobatteries.com](http://www.wecobatteries.com) website) and used according to the warranty instructions published on the website.

CAN/BMS communication is essential both for active and passive safety reasons and in order to be able to conduct all active control interactions with the inverter. The BMS has dynamic algorithms that vary according to current or previous conditions stored during the charge-discharge or stand-by phases.

Modern inverters/charge controllers are equipped with a CAN/BMS interface and no special settings are required to charge and discharge the battery, except for the setting of the charge/discharge power and the DoD% (if the customer wants to comply with the STC requirements, he must read and comply with the warranty conditions defined as STC and set them on the inverter).

Maintenance at optimal temperature, on the other hand, must be guaranteed by the technical room and the air conditioning equipment installed in it, the inverter is not able to interact with the settings with reference to the temperature of the environment in which it is installed, also because the inverter and battery could be exposed to different environmental factors in different environments.

## Warranty (Functional Warranty Against Manufacturing Defects) and Performance Warranty

Although the battery BMS allows a wide range of use both in terms of temperature and charging currents, this should not be interpreted as an implicit authorization to use the battery at these levels with reference to the performance warranty.

For the purposes of the performance warranty, it is mandatory that the battery is used within the range of temperature and charge/discharge current and depth of discharge indicated in the warranty itself and also reported in these paragraphs.

Any other use, even if permitted by the BMS thresholds, is not covered by the performance guarantee.

## Firmware Updates

In the event of BMS firmware updates as a result of improvements, corrections, or other reasons, this manual and warranties may be updated accordingly. Check the release notes for critical firmware on the site [www.wecobatteries.com](http://www.wecobatteries.com) at your distributors. **Critical Release Firmware must be installed as per warranty requirements.**

To obtain support if your system is not equipped with a WiFi module, please contact [service@wecobatteries.com](mailto:service@wecobatteries.com).

All WeCo batteries produced since the beginning of 2019 can be equipped with a WiFi system for connection to the WeCo Cloud, this solution ensures that you are always updated to the latest FW version notified in the APP, the Upgrade function must still be piloted by the user as during the update the battery will have to turn off for safety reasons and it is therefore necessary to plan this action in such a way that no inconvenience is created for the users of the system.

The FW update can also be carried out locally via Bluetooth App, even in the absence of WiFi; you must have a 4G connection and keep the Bluetooth App open until the App displays: "NEW FIRMWARE AVAILABLE" after which you can reach the battery in an area not covered by data signal and/or Wi-Fi and perform the FW update via the BT connection.

The customer has the right to subscribe to the newsletter to obtain information regarding the firmware release and any other communication regarding the products and their use.

**Any security enhancement update is released as critical and must be installed by the customer or their designee within the deadline**  
**Sign up for the WeCo newsletter to receive emails with your battery's technical updates and critical FW update**

## ERRORS

In the event of a permanent error with red LED on the LED bar, **do not restart or reset the battery and contact the after-sales service**, incorrect manoeuvres could cause damage to people or property, isolate the battery from the inverter immediately if such errors are detected.

## BMS

acronym for Battery Management System, which is a combination of sensors and processors assembled in PCBs in order to monitor and control cells under various aspects such as: Temperature, Current, Voltage.

The logical part, on the other hand, has the multiple function of processing all this data and controlling the battery to stay within defined thresholds.

Il BMS svolge anche la funzione di interfaccia di comunicazione esterna con l'inverter o il controller del caricabatterie per impostare attivamente il parametro operativo che la batteria può sopportare in quel particolare momento.

The BMS logic part is also responsible for calculating the SOH SOC and storing real-time battery data, warnings, alarms, operating time and various other useful parameters

## SOC

**The soc is not measured, it is a calculation derived from quantities such as voltage, current and temperature.**

State of charge (SOC) calculation in lithium batteries is a method used to estimate the percentage of charge remaining in a battery.

The calculation is based on voltage, current, and temperature, and can also be used with algorithms to account for age and battery usage history.

The SOC value is an estimate and is not accurate as many factors may affect the daily calculation, for this reason it is important to reset the SOC calculation by fully charging a battery to the maximum, **to reach 100%, at least once a month**, the user is responsible for charging the battery at least once a month to 100%, Reaching 99% is not enough. This will reach the upper limit of the battery and the SOC can be reset to a known point.

## SOH

SOH is an estimate expressed as a percentage, which indicates the current capacity of a battery compared to its initial condition when it was new.

It reflects the battery's ability to store and provide energy during aging, SOH is not a reliable value and has no contractual value, it serves as a statistical approximation of battery use.

It is an indicative and statistical figure with no contractual value

**Optimal chemical reactions:** Chemical reactions within the battery occur efficiently within the cell temperature of +15 °C +30 °C, providing a balance between performance, longevity and safety

**Optimal temperatures:** For any lithium-ion battery the best operating cell temperature is between 20 °C and +30 °C, which means staying within an ambient temperature of +15 °C + 25 °C

**Optimal temperatures for improved safety and performance:** Optimal capacity, charging speed, and cycle time are guaranteed within the temperature ranges stated above. Installing batteries in air-conditioned environments such as cabinets or technical rooms is always the best solution for their safety and longevity.

**Reduced capacity:** caused by the temporary effect of temperature on chemical reactions but it is also an irreversible effect caused by the three factors: Use/current ratio – Temperature of use -Aging

**Slower charging:** This is typically a reaction of the BMS to impose a slow current due to low temperature, this leads to an irreversible effect in addition to the reduced capacity effects explained above. Slow charging is also a good practice when the battery is at its optimal temperature, in fact using the battery at 0.2/0.5C will ensure greater capacity/safety/longevity

**Plating effect:** In low-temperature operations, so charging and discharging at very low temperatures, lithium deposits on the anode can lead to internal battery damage, early loss of capacity, and reduced safety.

**Higher capacity and conductivity:** High cell temperatures (above 30-35°C) can increase the relative capacity and conductivity of the battery. Giving a false effect of "better performance". This is a short-term benefit as battery degradation accelerates to high temperatures.

**Accelerated aging/degradation:** Exposure to high temperatures leads to accelerated aging of the battery. It can cause electrolyte degradation, separator damage, and increased internal resistance, especially under low voltage and persistent low temperature conditions.

**Thermal runaway:** The cell exposed to high temperatures can overheat and potentially lead to a cell valve vent and/or fire due to electrolyte gasification.

**Thermal runaway due to plating and dendrites:** a "sneaky" consequence due to misuse of a lithium battery, e.g. exposure to low or high temperatures, excess discharge, excess exposure to low voltage in a cold environment, thermal runaway, cell venting due to an internal short circuit, and increased resistance that will cause persistent short circuit and cell deformation.

The galvanic effect is also a consequence of extreme undervoltage and subsequent reuse of the battery and in the long term could cause cell malfunction and possible short circuits, which is why a lithium battery found in extreme undervoltage conditions must never be reused and must be disposed of at a center authorized by a qualified company.

## Temperature Management Systems:

The fact that the battery 5K3 EVO is equipped with a heating system should not be understood as an implicit authorization to install the product in cold and/or unhealthy places, the heating system serves as an aid in the event that the temperature of the room falls below the permissible value for recharging.

## ATTENTION

### External protection switches between inverters and batteries

**External protection switches.** Switches and external protections **must be sized, selected and installed according to the indication of the system designer** according to the wiring diagram, the available short-circuit currents, the installation environment and the safety requirements of the site.

These devices (e.g. switches-disconnectors, MCB/MCCB, RCD/RCCB, SPD, DC/AC disconnectors, emergency stops) **must guarantee visible disconnection, adequate breaking capacity, selectivity and coordination** with the internal protections of the inverter and batteries. Additional **safety systems** (e.g., fire, barriers, ventilation/extraction, monitoring) may be required depending on site characteristics and applicable regulations. Compliance with local standards and regulations remains **the responsibility of the designer/installer**.

### Legal Information

Unless otherwise agreed, this document is intended to be used only as a guide to the installation, maintenance and management of the product, all statements, information and advice contained in the documentation do not constitute any express action or implied statement in contradiction with local regulations or standards.

For more information, please contact us.

Official information and the latest data sheet are available on [www.wecobatteries.com](http://www.wecobatteries.com); however, they can be requested in real time at [service@wecobatteires.com](mailto:service@wecobatteires.com). Hyperlinks, third-party links, digital datasheets published on web social media or even printed in print media may not be updated to the current version of the product. Before purchasing the product, check the website for technical data and warranties updated to the current date.

It is essential that the battery unit is equipped with the latest firmware version available on the [www.wecobatteries.com](http://www.wecobatteries.com) site or WeCo APPs.

From time to time, WeCo will release a new firmware to improve the functionality of the battery, if your battery is equipped with WiFi (paid accessory) and you are registered on our APP, the new firmware will be visible in the APP and can be updated with a simple click from your phone.

The latest firmware version is always available for free; the battery firmware can be updated by the local installer via RS232/USB and Windows PC (reserved for installation technicians) or via APP for batteries equipped with WiFi dongles.

You can also write an email to [service@wecobatteries.com](mailto:service@wecobatteries.com) to understand and be supported in the upgrade process.

To benefit from the guarantee, **the request must be received within 10 days of the event**, by sending a request via email to [service@wecobatteires.com](mailto:service@wecobatteires.com) or by filling out the RMA ticket



The 5k3-EVO battery module is designed to be used only in sheltered and restricted access environments.

The IP rating **should not be understood as implicit authorization for outdoor installation.**

**In any case, installation must be provided** in protected and sheltered environments from the weather

The place must be ventilated and dry, sheltered from extreme temperatures, which are harmful to the life and safety of the battery.

Use in an outdoor environment or not compliant with the IP degree is prohibited and potentially dangerous to the health of people and/or property.

### Production guarantee

Although the battery BMS allows for a wide range of use, both in terms of temperature and charging currents and DOD, this should not be interpreted as an implied authorization to use the battery at these levels.

For purposes of the Performance Warranty, it is mandatory that the battery be used in the range of temperature and charge/discharge current and depth of discharge indicated in the Performance Warranty.

The capacity is understood to be of the new product, within 3 months of production and stored as prescribed, the capacity test must be carried out at a base temperature of 25°C with saturation charge of the cells and then discharge test at 0.2C as prescribed by the warranty conditions. Write to [service@wecobatteires.com](mailto:service@wecobatteires.com) for more information.

See the Limited Warranty Document for more details

### Performance guarantees

This is an additional warranty and applies to the performance warranty expressed in cycles, provided that the battery has been used in accordance with the performance warranty usage criteria and only to batteries connected via a BMS line to an approved inverter. The battery's operating parameters must remain within the performance warranty terms throughout its useful life, otherwise the performance warranty will not apply.

Any other use, even if permitted by the BMS ranges such as limits exceeding the values indicated by the performance warranty, is not covered by the performance warranty, but the legal warranties remain valid.

See the limited warranty document available on the website [www.wecobatteries.com](http://www.wecobatteries.com) in the download and warranty area.



### Important Battery Safety Information

Knowing a lithium battery is important for good and optimal storage. An additional information guide to the manual is available and you can request it from WeCo by writing to [service@wecobatteries.com](mailto:service@wecobatteries.com)

#### MISUSE

It is not allowed to use a battery that has been affected by:

- Overvoltage
- Under voltage (excess discharge beyond the safe limit)
- Overtemperature
- Under temperature
- Overcurrent.

It is forbidden to use a battery that exceeds the operating limits of the BMS and the storage and use limits indicated in this manual

Nor is it prohibited, as it is absolutely dangerous, the battery must be disposed of in an authorized landfill

The use of batteries that have been used outside the operating parameters is dangerous and must be avoided at all costs.

It is absolutely forbidden to remove the BMS and replace it in order to continue using the battery.

Do not attempt to restart or re-operate the battery after such events by acting on the BMS or changing the functions of the BMS

## Scheduled Maintenance and Inspection Procedure – WeCo 5K3 EVO

### Maintenance and Inspection Procedure – WeCo 5K3 EVO

#### 1. Purpose and Responsibility

This procedure defines **activities, frequencies, acceptance criteria** and **records** for the routine maintenance of the 5K3 EVO (low voltage) system.

The execution is **reserved for qualified and authorized personnel**. The **designer/installer/operator** is responsible for compliance with applicable standards and for maintaining the required environmental conditions.

#### 2. Preliminary safety (mandatory)

**PPE:** Insulated gloves, goggles/visor, anti-static shoes; DPI arc-flash when appropriate.

**LOTO:** Apply **Lock-Out/Tag-Out** on all sources (AC network, PV/DC, groups).

**No voltage:** Check with a CAT III/IV multimeter that the terminals are  $\approx 0\text{ V}$  before operating.

**Work area:** forbidden to non-professionals; ensure adequate ventilation and lighting.

**Prohibitions:** no DC hot-plugs, no live parts, no use of non-approved spare parts.

#### 3. Conditions and tools

**Environment:** site **sheltered** from precipitation/splash/dust; no persistent condensation.

**Minimum tools:** calibrated multimeter, torque wrenches with certificate, suitable anti-oxidation protective spray, non-conductive cleaning kit, smartphone with **WeCo APP**.

**Tightening torques:** only follow the official table in the 5K3 EVO manual.

#### 4. Frequencies

**Monthly (30 days):** 100% SOC verification via APP; alarm/log check, the system must be 100% calibrated with a forced charge if necessary

**Quarterly (3 months):** general cleaning/inspection; electrical checks; APP/SOC-SOH verification.

**Six-monthly (6 months):** in-depth HV **BOX checks**, breakers, contactors, fast-plug, RJ45; tightening and mechanical status recheck.

#### 5. Activities and acceptance criteria

##### 5.1 Monthly verification (30 days)

###### Activity

Check via **WeCo APP**: SOC, SOH, voltages/currents, temperatures, events/alarms.

Confirm **SOC achievement = 100%** at least 1 time/month (full equalization cycle, if expected).

###### Acceptance criteria

No active/pending alarm; SOC 100% achieved; deviations readings consistent with specifications.

###### Corrective

In case of repeated alarms or failure to reach 100% SOC for 2 consecutive cycles: open tickets to **WeCo Service**, register Case ID and follow instructions.

##### 5.2 Quarterly Audit (3 months)

###### Activity

**Cleaning/visual inspection:** remove dust and foreign bodies; check **for oxidation/rust on** terminals, BUS BARS, connectors, body.

**Electrical connections:** check **tightness** (see torque table in the manual); check the integrity of the DC/AC cable insulation and correct installation (no crushing/radius < minimum).

**APP & monitoring:** analyze SOC/SOH **graphs**; check **V/I consistency** between modules.

###### Acceptance criteria

Dry and clean surfaces; no visible oxidation; tightening within tolerance; no sheath damage; regular SOC/SOH trends; Differences in module voltages within manual limits.

###### Corrective

Cleaning with a suitable product; restoration of rubber/silicone protections; restoration of tightening; replacement of damaged components/kits only with **WeCo spare parts**.

##### 5.3 Semester Verification (6 months)

###### Activity

**HV BOX:** check power and communication wiring; inspect power and CAN terminals; **open/close** test breaker;**contactor test** with emergency stop simulation.

**Fast-Plug:** check for play/wear/deformation; check **for water tightness** (gaskets, contact surfaces).

**RJ45/CAN:** check cables free of crushing/cuts; inspect plugs/ports for absence of oxide/corrosion; check firm hooks and correct **120  $\Omega$**  termination where provided.

**Mechanical checks:** recheck **tightening** with a torque wrench; check brackets, screws and anchors.

**Advanced cleaning:** remove any deposits, use **anti-oxidation spray** where necessary.

#### **Acceptance Criteria**

Breakers/contactors with smooth functionality (no gluing/delays); stable CAN continuity (no errors/CRC in log); undamaged fast-plugs; RJ45 oxide-free; compliant couples; no cracking, no foreign body.

#### **Corrective Action**

Replacement of faulty/worn components; gasket restoration; oxidation restoration; firmware update when requested by WeCo.

#### **6. Records and traceability (mandatory)**

Fill in **maintenance checklists** with **date, time, operator, serial numbers** and **results**.

Store APP **logs/screenshots** (SOC/SOH/ALARMS) and tightening reports (applied values).

Open **tickets** to WeCo in case of anomalies and write the case ID on the checklist.

Keep records for at least **5 years** (or period required by local law/contract).

#### **7. Non-conformity and warranty**

Failure to carry out the planned activities, the use of non-approved spare parts or environmental non-compliance may result in **warranty limitations/exclusions** within the limits of the law and the **WeCo Warranty Terms**.

Any non-conformity must be **removed before** recommissioning; commissioning with open defects on safety/insulation/tightening is prohibited.

#### **8. Operational annexes**

**Maintenance checklist** (monthly/quarterly/half-yearly) with signature fields and notes.

**Tightening torque report (official manual table 5K3 EVO)**

**Intervention report form** and attachments with "before/after" photos.



Activity	Outcome ( <input type="checkbox"/> OK / <input type="checkbox"/> N.C.)	Note
APP – 100% SOC Achievement Verification (at least 1x/month)	<input type="checkbox"/> OK <input type="checkbox"/> N.C.	
APP – No Alarms/Warnings and SOC/SOH Reading Consistency	<input type="checkbox"/> OK <input type="checkbox"/> N.C.	
Cleaning – No dust/deposits/moisture	<input type="checkbox"/> OK <input type="checkbox"/> N.C.	
Visual inspection – No oxidation/rust on the body, clamps, connectors	<input type="checkbox"/> OK <input type="checkbox"/> N.C.	
Electrical connections – Tightening according to WeCo manual table	<input type="checkbox"/> OK <input type="checkbox"/> N.C.	
DC/AC Cables – Integrity, Insulation and Proper Routing	<input type="checkbox"/> OK <input type="checkbox"/> N.C.	
HVBOX – Intact power/COM wiring	<input type="checkbox"/> OK <input type="checkbox"/> N.C.	
HVBOX – Breaker: open/close test	<input type="checkbox"/> OK <input type="checkbox"/> N.C.	
HVBOX – Tripping contactors: emergency stop simulation test	<input type="checkbox"/> OK <input type="checkbox"/> N.C.	
Fast Plug – Mechanical integrity (no play/wear/deformation)	<input type="checkbox"/> OK <input type="checkbox"/> N.C.	
Fast Plug – Tenuta acqua: guarnizioni integre e sedi pulite	<input type="checkbox"/> OK <input type="checkbox"/> N.C.	
RJ45 – Cables without abnormal crushing/cuts/bends	<input type="checkbox"/> OK <input type="checkbox"/> N.C.	
RJ45 – Oxide/Corrosion Free Plugs and Interior Doors	<input type="checkbox"/> OK <input type="checkbox"/> N.C.	
RJ45 – Firm hooks, no false contacts	<input type="checkbox"/> OK <input type="checkbox"/> N.C.	
Mechanical Fixings – Brackets and screws intact, no cracks	<input type="checkbox"/> OK <input type="checkbox"/> N.C.	
Advanced Cleaning – Contacts treated with anti-oxide protective (if necessary)	<input type="checkbox"/> OK <input type="checkbox"/> N.C.	
Notes/Anomalies found	<input type="checkbox"/> OK <input type="checkbox"/> N.C.	

Operator Declaration:

The activities listed above have been carried out according to procedure and in compliance with safety regulations.

- THERE ARE NO DISCREPANCIES
- DISCREPANCIES FOUND, THE SYSTEM IS ISOLATED AND MADE SAFE

Operator signature	Time and data

# Summary

Premise: .....	9
Declaration .....	9
<b>1. About this document.....</b>	<b>21</b>
1.1 Validity and acquisition of information .....	21
1.2 Subject matter .....	21
1.3 Contents of the manual.....	21
1.4 Firmware and software .....	21
1.5 Symbolic conventions.....	21
1.6 Acronyms of this manual .....	22
<b>2. Safety Instructions .....</b>	<b>22</b>
2.1 Intended Use .....	22
2.2 Important Safety Instructions.....	23
2.3 Installation Environment Requirements.....	24
2.4 Personnel requirements .....	25
2.5 Battery Handling and Moving.....	25
2.6 Hazardous material .....	25
2.7 Battery Storage.....	26
2.8 Battery Disposal.....	26
<b>3. Product Overview.....</b>	<b>26</b>
3.1 Product Introduction .....	26
3.2 Battery Module Introduction .....	27
3.3 HV BOX Module Introduction (Mandatory for High voltage configuration, not needed for low voltage) .....	30
<b>SECTION 2 – LOW VOLTAGE CONFIGURATION .....</b>	<b>33</b>
<b>4. Low Voltage (LV) Configuration .....</b>	<b>33</b>
4.1 LV Setup Introduction.....	33
4.2 Checking the Pre-Installation Accessory Set List .....	34
4.2.1 LV Accessories List .....	35
4.2.1.1 LV Battery Standard kit.....	35
4.2.1.2 LV Optional Accessory Kit .....	36
4.3 General preparation .....	37
4.3.1 Installation Location .....	37
4.3.2 Installation Tools .....	38
4.4 Install the battery module .....	39
4.4.1 Wall Installation.....	39
4.4.2 Stacked installation .....	41
4.5 Electrical connection .....	46
4.5.1 Instructions for Electrical Connection of a Low Voltage Battery .....	46
4.5.2 Single battery connection in low voltage data/signals and checks .....	48
4.5.3 Parallel Battery Connection.....	51
4.6 System commissioning and decommissioning .....	55
4.6.1 Check before activation.....	55
4.6.2 System Commissioning.....	55
4.6.3 System Decommissioning.....	59
<b>SECTION 3 – HIGH VOLTAGE CONFIGURATION .....</b>	<b>60</b>
<b>5. High Voltage (HV) Configuration .....</b>	<b>60</b>
5.1 HV Configuration .....	60
5.2 Pre-Installation check .....	60
5.2.1 List of Accessories Included with Battery .....	61
5.2.1.1 HV Battery Standard Accessory Pack.....	61
5.2.1.2 HV BOX Standard Accessories Package .....	62
5.2.1.3 5HV Optional Accessory Kit (for use with two towers) .....	63
5.3 General Preparation .....	64
5.3.1 Installation Location .....	64
5.3.2 Installation Tools .....	65
5.4 Install the Battery Module and HV BOX Module .....	66
5.5 Electrical Connections .....	73
5.5.1 Electrical Connection Diagram .....	73

	73	
5.5.2	Connection Procedure .....	74
5.6	System commissioning .....	78
5.6.1	Pre-commission check .....	78
5.6.2	System Startup .....	78
5.6.3	System Deactivation .....	81
<b>6.</b>	<b>WECO WIFI App Operation .....</b>	<b>82</b>
6.1	App Introduction .....	82
6.1.1	Copyright Notice .....	82
6.1.2	Manual Contents .....	82
6.1.3	Manual Instructions.....	82
6.1.4	Usage Requirements .....	82
6.1.5	Registering a WECO WIFI APP Account .....	82
6.2	Log in and Disconnect the APP .....	83
6.2.1	Log in to the APP .....	83
6.2.2	Logout from the APP .....	84
6.3	Add the first device.....	84
6.3.1	Add another device .....	85
6.3.2	Display Device.....	86
6.3.3	Display the main parameters of the device.....	86
6.3.4	Viewing Trend Charts .....	87
6.3.5	Display Detailed Device Parameters.....	87
6.4	Frequently Asked Questions.....	88
6.4.1	How to reset your password by email if you have forgotten it? .....	88
6.4.2	Resetting the user's password.....	88
6.4.3	When the user logs in to the app, asks how to fix the network anomaly? .....	88
6.4.4	Device Not Displayed After Adding .....	88
6.4.5	Network Changes: How to Reconfigure Device Network.....	88
<b>7.</b>	<b>WECO Bluetooth App Operation .....</b>	<b>89</b>
7.1	App Introduction .....	89
7.1.1	Copyright Notice .....	89
7.1.2	Manual Content.....	89
7.1.3	Manual Instructions.....	89
7.1.4	Usage Requirement .....	89
7.2	Log in and log out the APP.....	90
7.2.1	Log in to the APP .....	90
7.2.2	Exit the APP .....	91
7.3	View Device and Setup .....	91
7.3.1	Display the main parameters of the device.....	91
7.3.2	Set the Battery Protocol .....	92
7.3.3	Always update the firmware to the latest version .....	93
<b>8.</b>	<b>Storage.....</b>	<b>94</b>
8.1	Storage - Transport - Removal / Transfer of batteries .....	94
<b>9.</b>	<b>Maintenance and Replacement.....</b>	<b>95</b>
<b>10.</b>	<b>Battery Module Disposal .....</b>	<b>96</b>
10.1	Remove the Battery.....	96
10.2	Packing the Batteries.....	96
10.3	Dispose Batteries.....	96
<b>Appendix A Battery Module Technical Parameters.....</b>		<b>97</b>
<b>Appendix B Battery Label .....</b>		<b>97</b>
<b>Appendix C HV Box Technical Parameters .....</b>		<b>99</b>
<b>Appendix D HV Box Label .....</b>		<b>100</b>
<b>Appendix E HV INVERTER COMPATIBILITY .....</b>		<b>101</b>
<b>Appendix F LV INVERTER COMPATIBILITY .....</b>		<b>102</b>

# 1. About this document

## 1.1 Validity and acquisition of information

This manual applies to the WECO 5K3-EVO battery module. Only qualified personnel authorized under the laws of their country may install, troubleshoot, and maintain battery modules.

In the event of a product revision, this manual will be modified accordingly. Unless otherwise agreed, this document is intended solely as a guide, and all statements and information contained in the documentation must not contain any express contradiction with local regulations or standards.

For further information, please do not hesitate to contact us.

Official information and the latest technical data sheet are available at [www.wecobatteries.com](http://www.wecobatteries.com).

## 1.2 Subject matter

The instructions contained in this document may only be carried out by qualified persons within the meaning of applicable laws:

- Installation and maintenance person (authorized supplier or installer)
- Owner or User trained and informed by the installer

Failure to do so shall result in any warranty or liability of the manufacturer being disclaimed.

## 1.3 Contents of the manual

This manual contains information and instructions on safety, battery module overview, installation, electrical connection, maintenance and storage, battery module disposal, technical parameters. Please finish reading this manual carefully before performing any operation on the battery module.

## 1.4 Firmware and software

It is essential that the battery module is equipped with the latest firmware version available. The new batteries are equipped with the latest firmware version, however before commissioning please check via Bluetooth or WiFi APP for the latest available FW version or search for it on <https://wecobatteries.com/download-area/>.

From time to time, the firmware will be updated to improve the features and capabilities of the battery.









The latest firmware version is always available for free and can be updated by your local installer. You can always contact [service@wecobatteries.com](mailto:service@wecobatteries.com) for more information about the upgrade process.







In the case of a critical update release, the user must install the firmware within 60 days of release.

To stay up to date on firmware releases, please register for the newsletter, check the APP for new firmware notifications and/or check the weco website download area for your battery model.





## 1.5 Symbolic conventions

### Warning symbol

Etichetta	Detail
 Warning	WARNING provides information that should be noticed and taken care of.
 ATTENTION!	CAUTION represents situations that may cause property damage if not avoided.
 Danger	DANGER represents hazardous situations that can cause injury if not avoided.
 Information	Used to highlight important/critical information, best practices, tips, etc. "Instructions" are not safety information and do not include information about people, equipment, and environmental injuries.
 Electric Shock Warning	This label indicates that there is high voltage inside the product and touching it may cause an electric shock.
 Class 9 Miscellaneous Hazardous Substances and Objects	Substances and objects which, during transport, present a hazard that is not included in any of the other classes are classified in class 9.
 The battery must be recycled. 	The battery must be recycled

	No fire symbol	Fire is strictly forbidden within 40mt
	Dangerous goods	This label indicates that there is a hazardous risk of explosion that could be induced by the product
	Limit temperature mark	This label indicates that there is a temperature limit of the product.
	Keep dry	This label indicates that the product is capable of continuing to do so.
	Caution: may generate flames	This label indicates to avoid fire to the product.
	UN Mark 3480	Follow the UN regulations in place to ensure the safety of those transporting for lithium battery products.

### Description of the certification mark

Icon	Name	Meaning
	Follow current UN regulations to ensure the safety of those transporting products with lithium batteries	This product meets CE certification standards
	EU WEEE logo	EU WEEE logoLogo RAEE dell'UE
	RoHS Mark	This product is RoHS compliant.
	Recycle Mark	The battery is recyclable

The battery is recyclable and must be recycled by a specialized company in accordance with the directives of your municipality or country of residence.

### 1.6 Acronyms of this manual

No.	Term	EEVolutionation
1	SoC	State of charge
2	DoD	Depth of Discharge
3	Charge	Charged energy
4	Discharge	Discharged energy
5	BMS	Battery Management System
6	Firmware	BMS Logic Control Software

## 2. Safety Instructions

### 2.1 Intended Use

5K3-EVO is a lithium iron phosphate battery module that can be used in low or high voltage configuration. If used with a high-voltage inverter, it must be equipped with HV BOX.



#### WARNING!

For low-voltage use, the extreme working voltage range is 44.8~56.8VDC; For high-voltage use, the working voltage range is 80~1000VDC. (\*Voltage ranges are estimates only as they always depend on interactions with other devices and environmental conditions). Make sure you use the correct inverter type or charging parameters before connecting it to the battery. Ensure that the battery configuration is compatible with the inverter's operating range. Use only WeCo-approved inverters.



HV BOX has a minimum starting voltage of 80 Vdc, (Two 5K3-EVO modules in series connection) however it may be necessary to use several battery modules to reach the operating voltage of the inverter. It is recommended to use a minimum of four modules to have an adequate energy buffer to avoid low-voltage shutdown of the HV BOX during a long standby period of the inverter, or due to inactivity of the solar charger. Starting inverters is typically higher than 100-120V DC, be sure to consider the voltage range of the inverter battery before setting up the battery cluster. The HV BOX can be switched on with a minimum of 80Vdc, however it is mandatory to respect the Nominal Voltage of the inverter. Below 80Vdc the HV BOX switches off and safety protection cannot be guaranteed. In an HV system the total usable energy of the cluster might be reduced due to imbalances between the modules, always consider fully balancing the individual modules before composing the HV cluster to maximize the power consumption of the cluster.



#### DANGER!

The battery module is dual voltage, it can be installed in both a high-voltage and low-voltage configuration, **but never at the same time. If the Low Voltage and High Voltage connectors are connected at the same time, serious accidents and damage to the battery and the systems connected to it will occur.**

Pay attention to the different connection methods and the specific use of the end connectors.

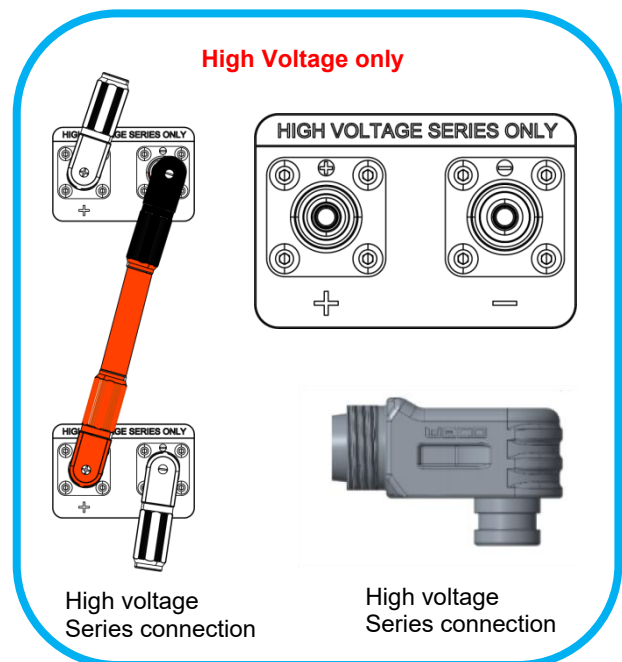
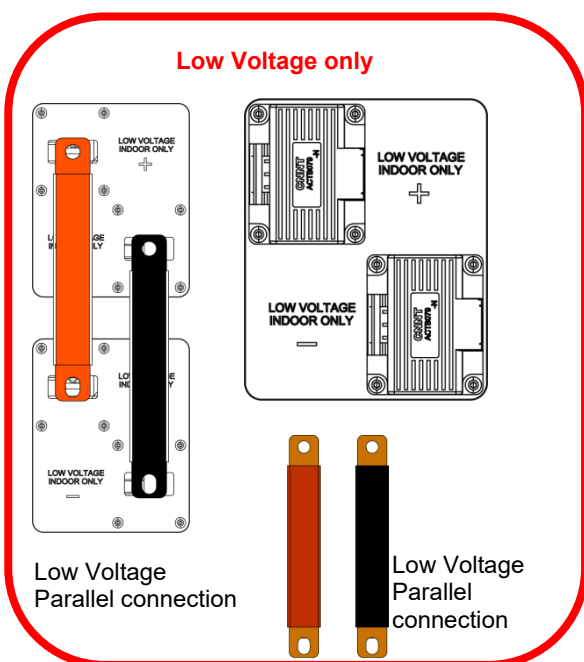



**WARNING:** The battery module or HV BOX (if in HV Configuration) should only be used in combination with a compatible inverter. Make sure the make and model of the inverter are within the compatible list of the 5K3-EVO battery module. Make sure you use the correct inverter charging parameters before connecting it to the battery. Be sure to select the corresponding inverter protocol in the 5K3-EVO battery configuration

## 2.2 Important Safety Instructions

The battery shows the main nameplate data on the rating plate, including **rated capacity** and **maximum** permissible current. The system and wiring must be designed and built in compliance with these limits.

The connection cables supplied (in the standard package or kit) are intended **only** for use in **standard conditions** and **within the operating limits of the battery**, and are **only** suitable if installed:

- according to the indications of this manual;
- according to the applicable technical standards (ISO/EN/UNI and/or national standards in force) and the rules of the art;
- in compliance with local requirements and any operator/network.

The cables supplied **must not be considered implicitly suitable** for any system configuration, type of installation, environmental condition or country of installation.

The final choice of **section, length, insulating material, type of installation, capacity and voltage drop**, as well as the correct coordination with the protections, must be verified **on a case-by-case** basis by the **qualified designer/technician in charge of the system**, who remains responsible for the regulatory compliance of the installation.

The cross-section and length of the cables supplied are based on "standard" laying conditions, including, but not limited to:

- cable **completely unwound** (no windings or coils);
- installation in the **air** with adequate ventilation;
- absence of direct exposure to solar radiation;
- ambient temperature between **-10°C and +40°C**;
- absence of groupings with other circuits such as to require flow reduction factors;
- voltage drop compatible with the design limits of the system.

Any different conditions (e.g. high ambient temperatures, installation in ducts/walkways, underground installation, grouping of several circuits, longer lengths, reduced ventilation, exposure to the sun, etc.) requires:

- the application of the relevant **correction factors** provided for by the regulations of the State in which the system is installed;
- a **new technical verification** of flow rate and voltage drop;
- the possible replacement of cables with components **suitable** for the specific application.

The use of unsuitable cables (due to cross-section, installation or environmental conditions) can cause **overheating, abnormal voltage drops, protective trips, damage to the system and safety risks**.

## **⚠ CAUTION ⚠**

The use of unsuitable cables (due to cross-section, installation or environmental conditions) may cause **overheating, abnormal voltage drops, tripping of protections, damage to the system and risk of fire or electrocution**.

**Always check** the sizing of the cables and compliance with local regulations with a **qualified technician** before commissioning, the cables supplied by WeCo may not be suitable for use in your system.

## Signal communication cables and wiring

### Routing and Disturbs Protection (EMC/EMI)

To reduce the risk of noise on CAN/RS485/ETH or other communication signals:

Separation from power cables

Keep communication cables separate from battery/inverter DC cables and mains AC cables.

Avoid long parallel paths; If unavoidable, keep as much distance as possible.

90° crossings

When communication cables need to cross Speaker cables, preferably do so at 90° to reduce inductive/capacitive coupling. U

Use dedicated signal channels/walkways, separate from the power channels.

Avoid passing the signal cables near the middle and upper part of the inverter, near contactors, relays, EMC filters, transformers, inductors, motor cables, generators as these devices are known to generate disturbances, even occasional ones, that can affect communication.

### Shielding and grounding

Prefer shielded cables (both for CAN and RS485 connections) when laid near distrulers and/or alternating current cables, these must in any case be laid as per the cable manufacturer's instructions and according to the designer's instructions.

Connect the shield according to the manual and the interface standard (CAN/RS485/ETH).

Avoid "flying earths" The shielded cable braid must be grounded as intended to prevent ground loops

Do not crush, bend beyond the minimum radius, or pull the cables, and respect the manufacturer's bending radius.

### Lengths and terminations

Observe the maximum lengths and terminations provided for any CAN termination at the ends of the line, after consulting with weco if necessary according to the use and/or in vases of the non-standard cable used.

### Ferrites and filters

In critical environments or with recurrent disturbances, consider the use of ferrites/clamps on communication cables near entry/exit points, according to technical guidance and site conditions.

### ⚠ CAUTION ⚠

Running communication cables near or parallel to data cables may result in loss of communication, intermittent errors, resets, or system malfunctions. In the event of anomalies, first check the path and shielding of the wiring, the loss of communication between the inverter and the batteries could lead to a stall of the system and the normal control and safety functions could fail, if this condition were to persist for a long time, negative effects would be generated on the batteries including their discharge.

## 2.3 Installation Environment Requirements

For high-voltage installation, it must be installed in a location that complies with IP66. For low-voltage installation, it must be installed in a location that complies with IP20. The battery should be installed in a well-ventilated environment to ensure good heat dissipation. Do not expose the battery to direct sunlight, rain, and snow.



### Warning

Installations in locations that do not comply with the requirements may result in failure and/or damage to the product, in which case the product warranty will be void.

## 2.4 Personnel requirements

All electrical connections on the WeCo 5K3-EVO Battery Module should only be made by qualified personnel.



### PERSONNEL REQUIREMENTS

Subjecting the battery to an unsuitable operating environment or damage, misuse, or abuse may result in health and safety hazards such as overheating or the potential for electrolytic smoke. All personnel must comply with safety precautions and observe all warnings as detailed in this document.

If any of the safety precautions or procedures described in this manual are not fully understood by the reader, the reader should not perform any operations on the battery until it has contacted the WeCo Technical Service Representative for clarification and confirmation of understanding of the correct procedure.



### WARNING

Installation personnel should not wear metal objects, such as watches, jewelry, and other metal objects when performing installations. Do not store uninsulated tools in tool pockets or belt while working near the battery to avoid short circuits and personal injury.



### WARNING!

The safety guidelines included in this document may not include or consider all regulations in the area of installation/operation. When installing and operating this product, the installer must review and consider applicable state and local laws and regulations in accordance with the product's industry standards.

Never install the battery within 40 m from gas pipes, fuels, flammables materials and near to the fire escape routes.

Always follow the safety inspector instruction for the design and safety precautions.

## 2.5 Battery Handling and Moving

The weight of a single WeCo 5K3-EVO battery module is 55 kg. Use the original packaging and follow all safety instructions if the battery module needs to be moved, to avoid damage to the product and personal injury.

• It is not recommended to move a battery to another system as aging and differences in usage may affect the safety of the system when connected.

- Always use new batteries from the same production batch when used in series connection
- Expansion of existing systems is allowed within 300 cycles or 1 year.
- The battery module and its accessories must be protected from damage before and during transport and handling.

- Do not pull, drag, or impact the battery module.
- Before handling and moving the battery module, measure the voltage at the point of the terminal before coming into contact with any terminal surface, to verify that there is no risk of electric shock.
  - Non influenzare i terminali durante lo spostamento dei moduli batteria ed è severamente vietato sollevare i moduli batteria attraverso i bulloni laterali.

## 2.6 Hazardous material

The materials contained in this product may pose a hazard only if the integrity of the cell or battery is compromised, physically, thermally, or electrically abused.

The following are the expected risks in such conditions: Causes skin irritation. It causes severe eye irritation. It can cause an allergic skin reaction. It causes damage to organs (bones, teeth) in the event of prolonged or repeated exposure. Very toxic to aquatic life. Harmful to aquatic life with long-lasting effects.

### Protection

Do not eat, drink, or smoke when using this product.

Wear gloves/protective clothing/eye protection/face protection.

Wash thoroughly after handling.

Work clothes contaminated during processing should be cleaned before the next use.

Do not disperse any washing residue and/or the battery itself into the environment, read the safety data sheet of the model 5K3-EVO before installation.

This product is a "hazardous chemical" as defined by the OSHA hazard communication standard, in any case it is classified as DG9 and UN 3480, so precautions are necessary in its processing, storage, transport and disposal, Read the regulations in force in your country.

Additional information is provided in the MSDS SDS Safety Data Sheet and UN 38.3 Report



### WARNING

Additional notes: Do not open or disassemble the battery. Do not dispose of in fire, mix with other types of batteries, charge beyond the specified speed, improperly connect, or short circuit, which may cause overheating, explosion, or loss of cell contents. Do not open or disassemble. Keep away from heat sources/sparks/open flames/hot surfaces.

Do not wear metal ornaments. Always use personal protective equipment and personal protection against electric shock, shock, and ejection.

### Action in case of exposure

Under normal conditions of processing and use, exposure to the chemical constituents of this product is unlikely but not impossible.

The chemicals are contained in a sealed aluminum housing, while the cells are fixed in a steel casing. The risk of exposure occurs only if the battery is used mechanically, thermally or electrically abnormally or as a result of an accident.



### INFORMATION

If battery modules leak electrolytes, exposure to the leaking chemicals should be avoided. Contact may cause skin irritation and chemical burns. If someone is exposed to the spilled chemicals, follow these steps:

Inhalation or ingestion: Induce vomiting if swallowed, evacuate the contaminated area, and seek immediate medical attention.

Skin contact: Wash thoroughly with water. If irritation or rash occurs, seek medical attention. Remove contaminated clothing and wash it before using it again.

Eye contact: Rinse thoroughly with water for several minutes and seek medical attention immediately.

Provide the SDS/MSDS document of the batteries to the clinicians

## 2.7 Battery Storage

Store as instructed in the Storage section of this manual, do not exceed six months without an inspection via Bluetooth debugging APP or via PC software to monitor the charging status. The storage temperature affects the SOC retention, if the storage temperature is not between 15 and 30 °C, the self-discharge may be 1-2% faster per month. Consider these factors in your storage strategies.

- Do not expose to strong oxidants.
- Do not short-circuit the battery module.
- The battery module cannot be stored in a high humidity environment.
- The battery module cannot be stored at high temperatures
- The battery module cannot be stored directly under the sun.
- Do not open or damage the battery. Leaked electrolyte is harmful, so contact should be avoided.
- Batteries should be stored separately in the package. Do not store batteries in the open air and stack them too high.
- Damaged batteries should be monitored during storage to avoid signs of smoke, flame, electrolyte leakage, or heat.

## 2.8 Battery Disposal

Dispose of the contents/container in accordance with local/regional/national/international regulations.

Always contact a professional company to disassemble and dispose of the battery.

Transport to an affiliated batterie collection center must be carried out by and at the expense of the customer, by means of qualified companies by and at the expense of the owner of the good.

# 3. Product Overview

## 3.1 Product Introduction

### FUNCTION

The WECO 5K3-EVO is a dual-voltage lithium iron phosphate battery module that can be used in low-voltage and high-voltage configurations. It could be used in on-grid, backup, and off-grid modes with compatible inverters.

For high-voltage use, the 5K3-EVO battery module must be used together with an HV box module, high-voltage use requires at least 2 battery modules and a maximum of 17 battery modules to form a cluster. A maximum of 10 clusters with a high-voltage configuration can be connected in parallel.

Refer to Chapter 5 for High Voltage Configuration

For low-voltage use, at most 15 battery modules can be connected in parallel with the bus bars supplied by WeCo or by means of duly designed and manufactured cables to form a cluster.

A maximum of 7 clusters with a low-voltage configuration can be connected in parallel via the LV HUB module. Refer to chapter 4 for the low voltage configuration.

Battery modules support wall and floor installation.

The battery modules can be monitored and configured via the Phone app through the built-in WiFi module.

### RULES FOR MODEL NAMES

Model Description: 5K3-EVO

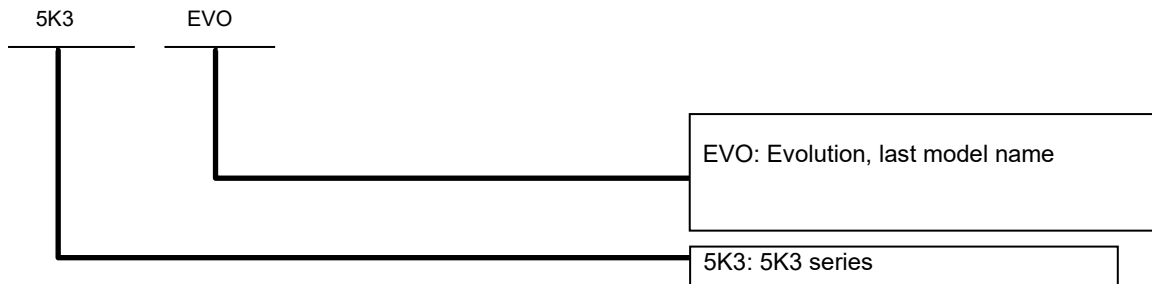

## 3.2 Battery Module Introduction

### OVERVIEW

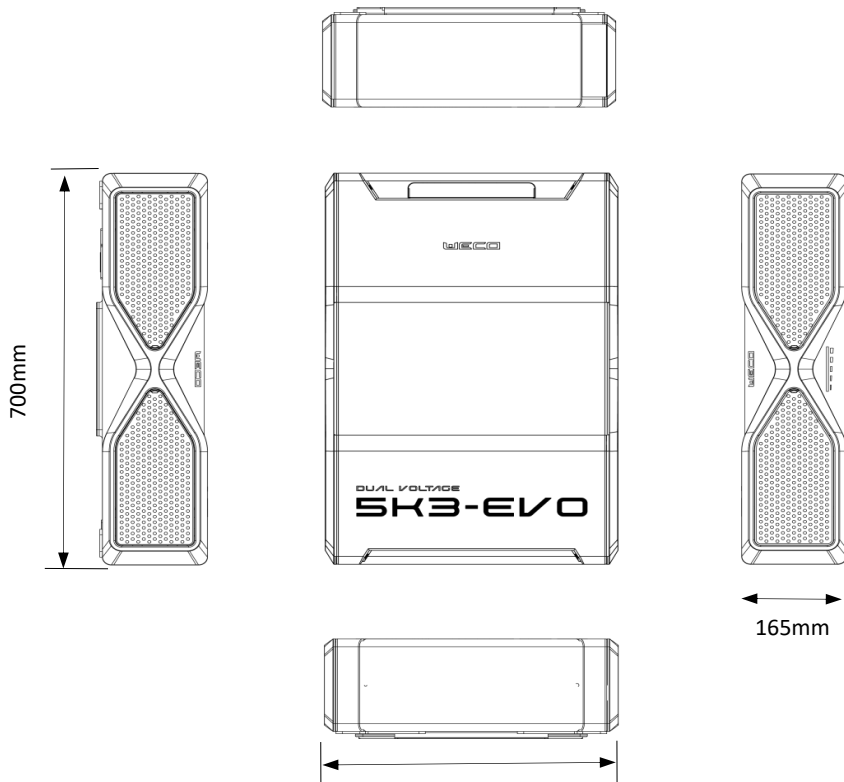

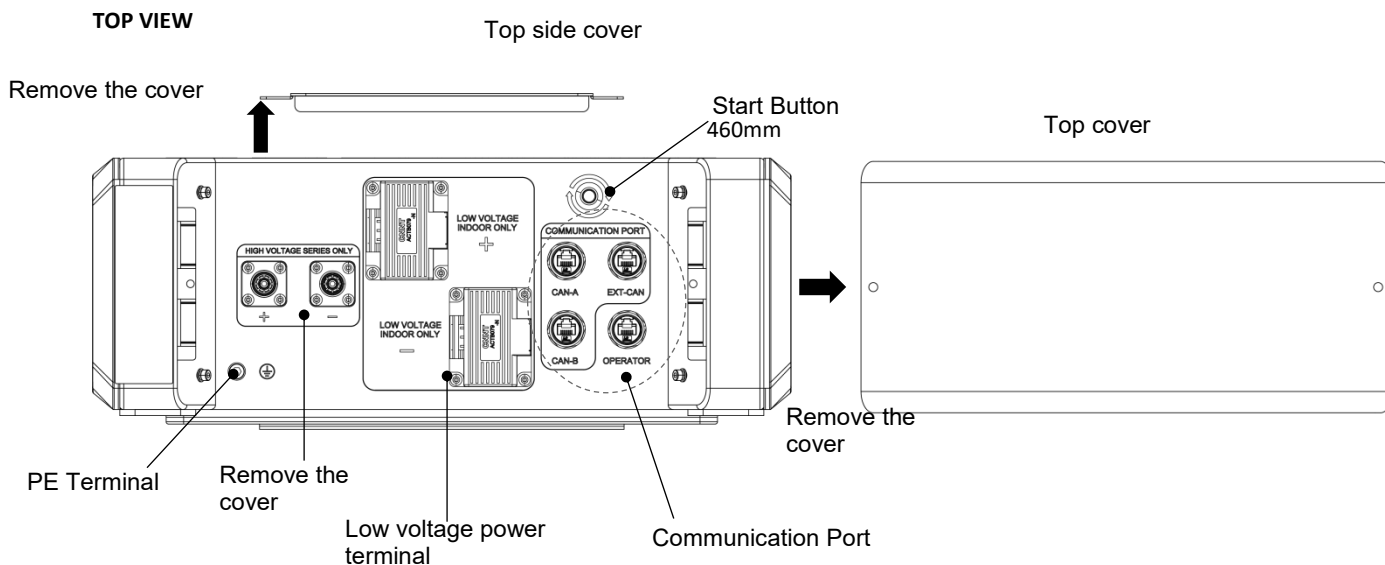

**Top view: Communication port**

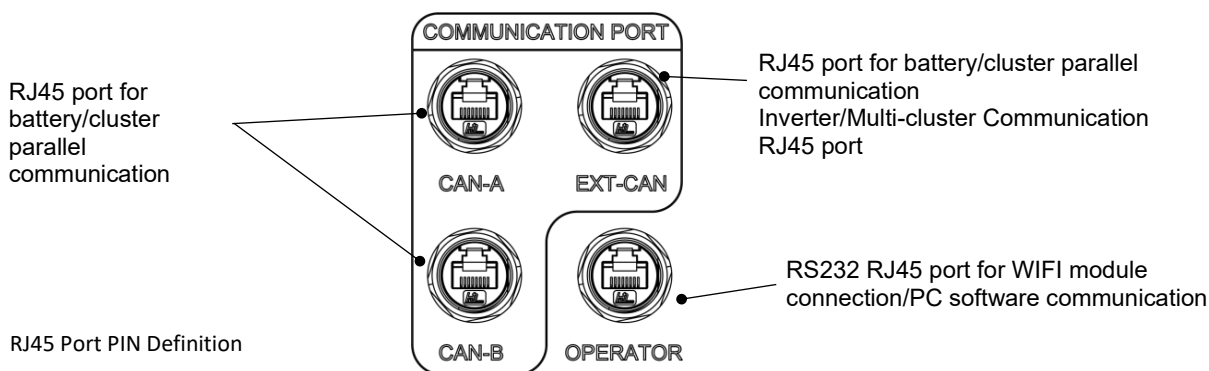

**RJ45 Port PIN Definition**

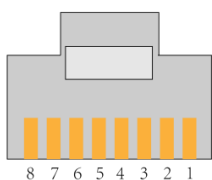

EXT-CAN: Inverter Communication/Multi-cluster								
PIN	1	2	3	4	5	6	7	8
	CAN1H	CAN1L	N/C	N/C	N/C	N/C	N/C	N/C
	Comunicazione inverter/multi-cluster							
CAN A: Single Cluster Wake Up Input/Multi-Cluster Communication								
PIN	1	2	3	4	5	6	7	8
	CAN1H	CAN1L	N/C	CAN2H	CAN2L	N/C	WIN+	WIN-
	Comunicazione multi-cluster			Single-cluster communication			BMS wake-up input	

CAN B: Internal Battery Communication								
PIN	1	2	3	4	5	6	7	8
	N/C	N/C	N/C	CAN2H	CAN2L	N/C	WDO+	WDO-
				Single-cluster communication			BMS wake-up output	
RS232-Operator Port: PC software communication								
PIN	1	2	3	4	5	6	7	8
	TX	RX	GND	5V+	N/C	5V_IN+	N/C	N/C
	RS232 PC Software Communication					Power Supply 5V+		

SIDE

**BATTERY MODULE SIDE VIEW**

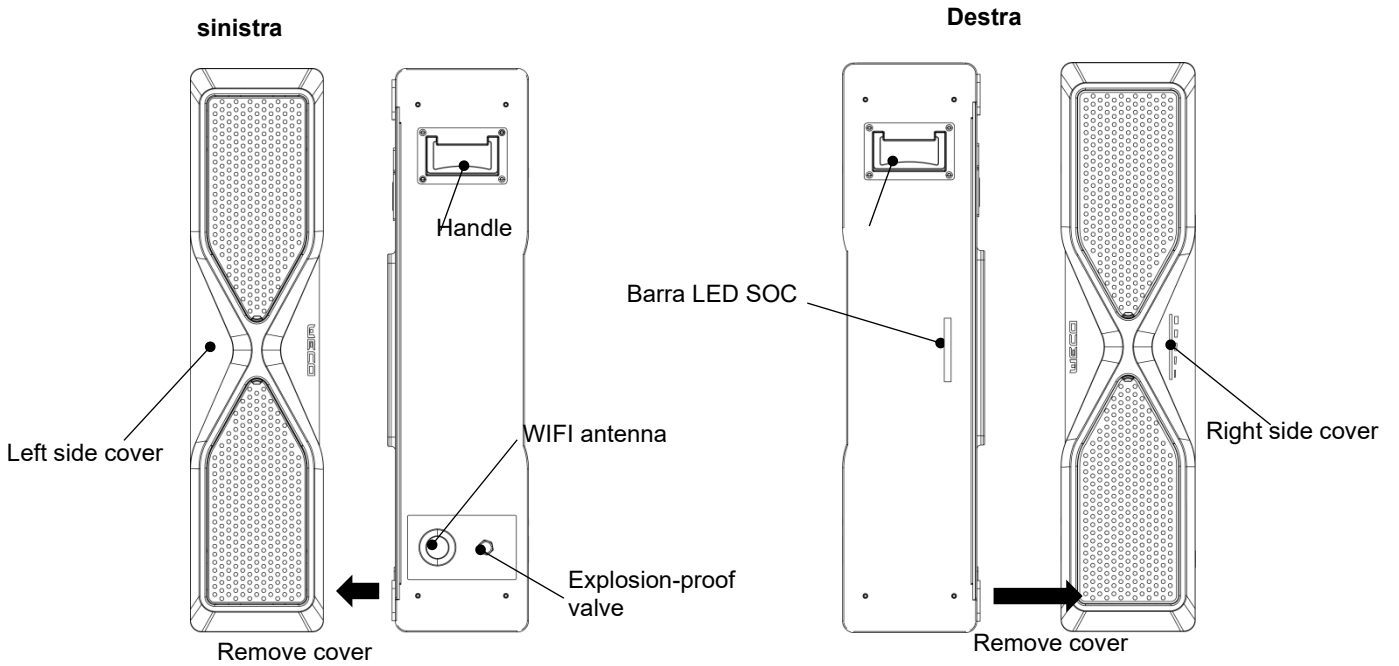

**BOTTOM VIEW (BMS SIDE)**

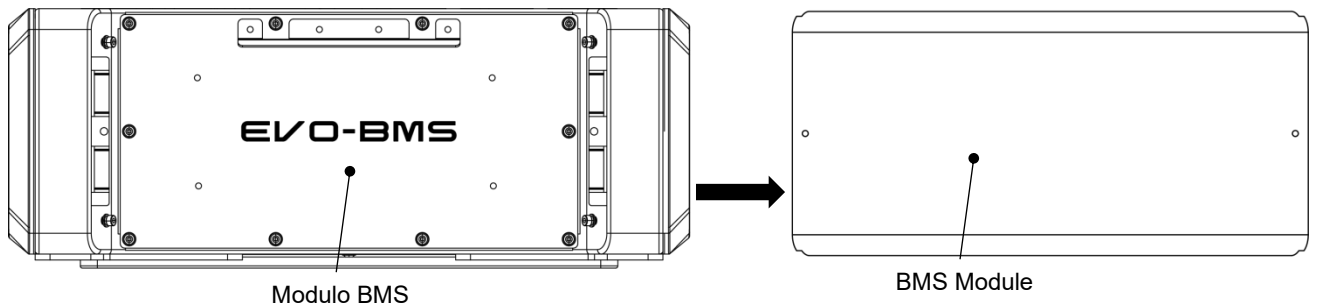

### 3.3 HV BOX Module Introduction (Mandatory for High voltage configuration, not needed for low voltage)

#### OVERVIEW

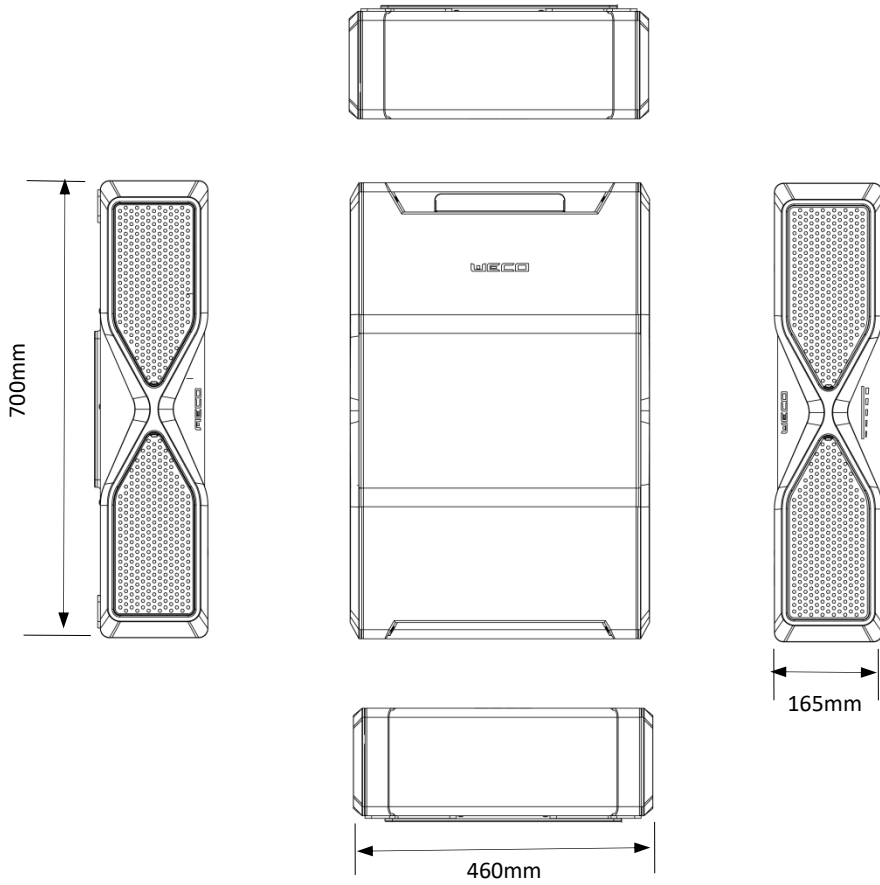

#### TOP VIEW – Single Channel

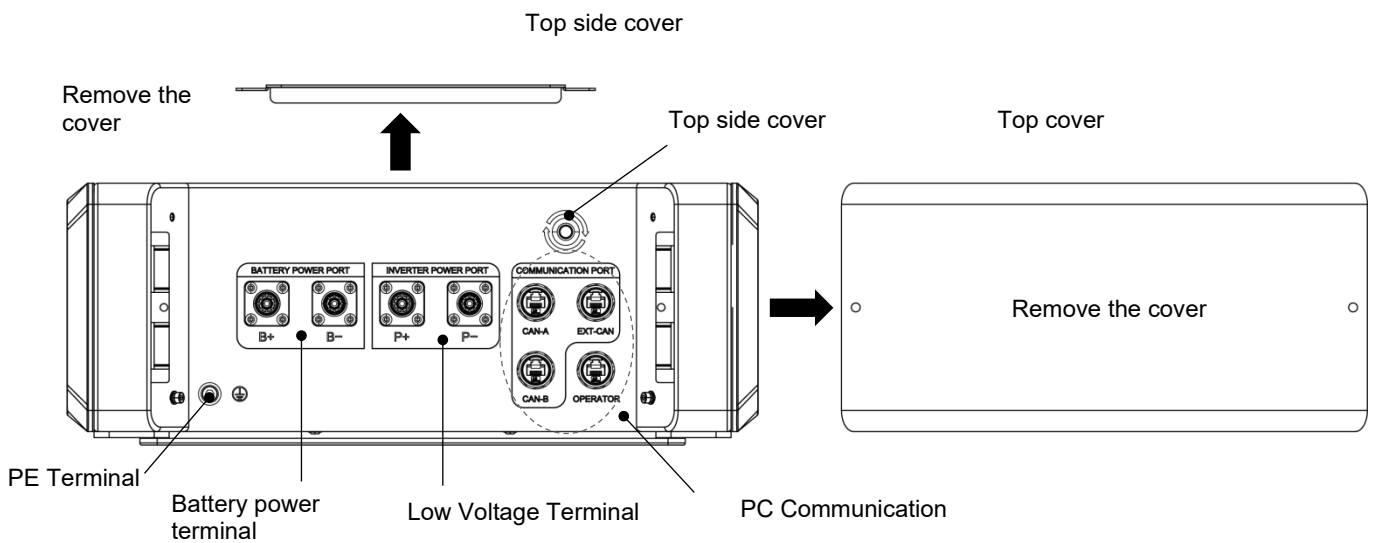

**TOP VIEW – Dual Channel**

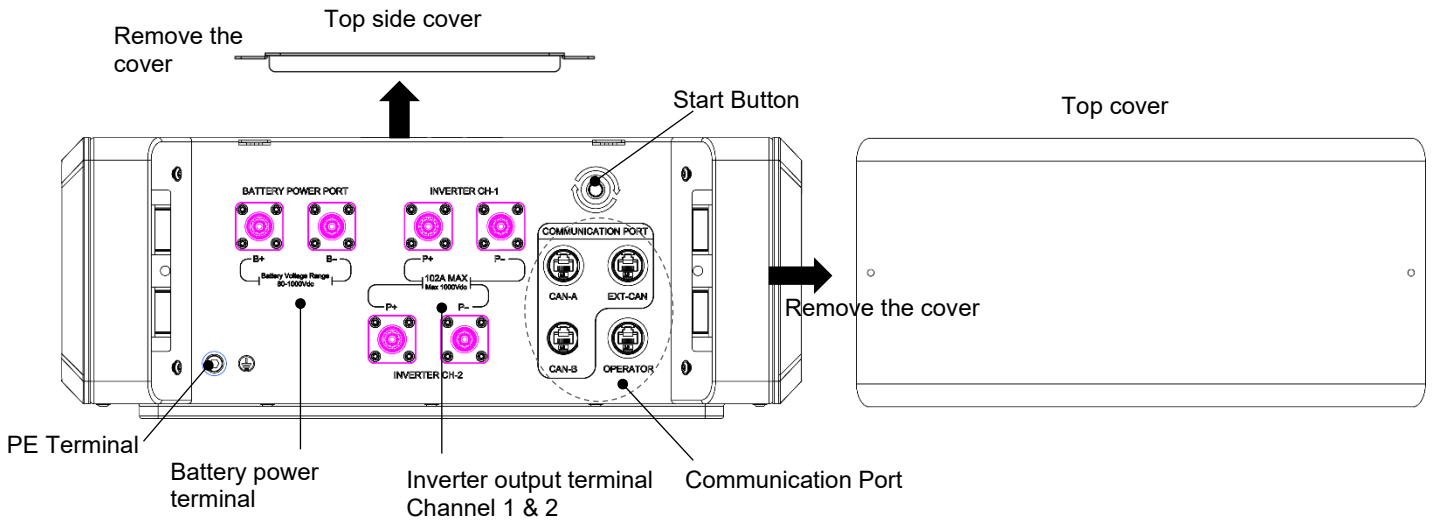

**TopView: Communication Port**

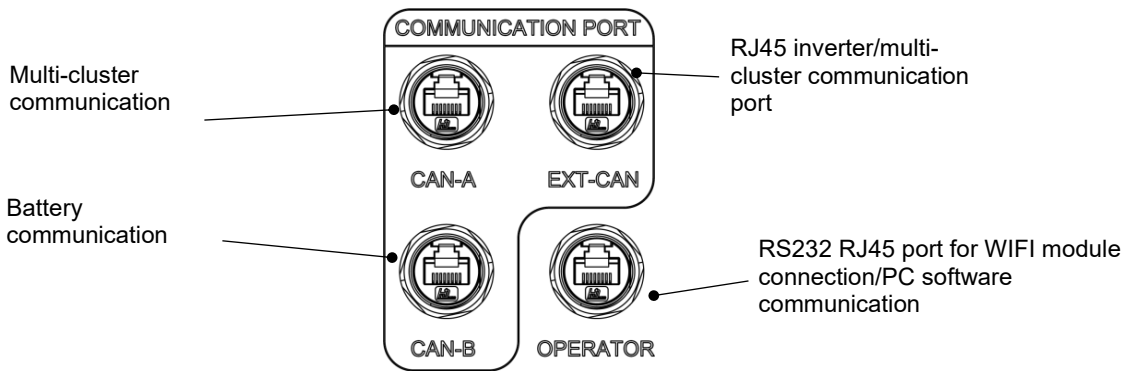

**RJ45 Port PIN Definition**

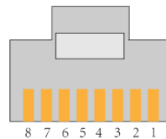

EXT-CAN: Inverter Communication/Multi-cluster								
PIN	1	2	3	4	5	6	7	8
	CAN3H	CAN3L	HIN_P	CAN2H	CAN2L	HIN_N	WIN+	WIN-
	Inverter Communication		Master and slave cluster identification: positive input	Multi-cluster communication		Master and slave cluster identification: Negative input	Cluster activation input	
CAN A: multi-cluster								
PIN	1	2	3	4	5	6	7	8
	N/C	N/C	HDO_P	CAN2H	CAN2L	HDO_N	C2_ID_WAKE U P_O+	C2_ID_WAKE U P_O-
			Master and slave cluster identification: positive input	Multi-cluster communication		Master and slave cluster identification: Negative input	Cluster wake up line	

CAN B: Battery communication								
PIN	1	2	3	4	5	6	7	8
	N/C	N/C	N/C	CAN1H	CAN1L	N/C	C1_ID_WAKE U P_O+	C1_ID_WAKE U P_O-
				Comunicazione con batteria di un cluster			Wakeup out inside a cluster	
OPERATOR: RS232 RJ45 port for WIFI module connection/PC software communication								
PIN	1	2	3	4	5	6	7	8
	TX	RX	GND	5V+	N/C	N/C	N/C	N/C
	RS232 PC software communication							

**SIDE VIEW HV BOX**

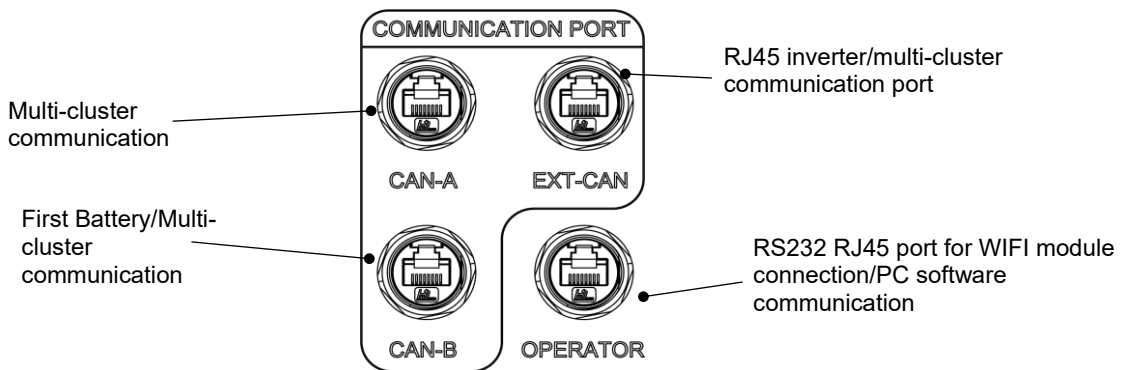
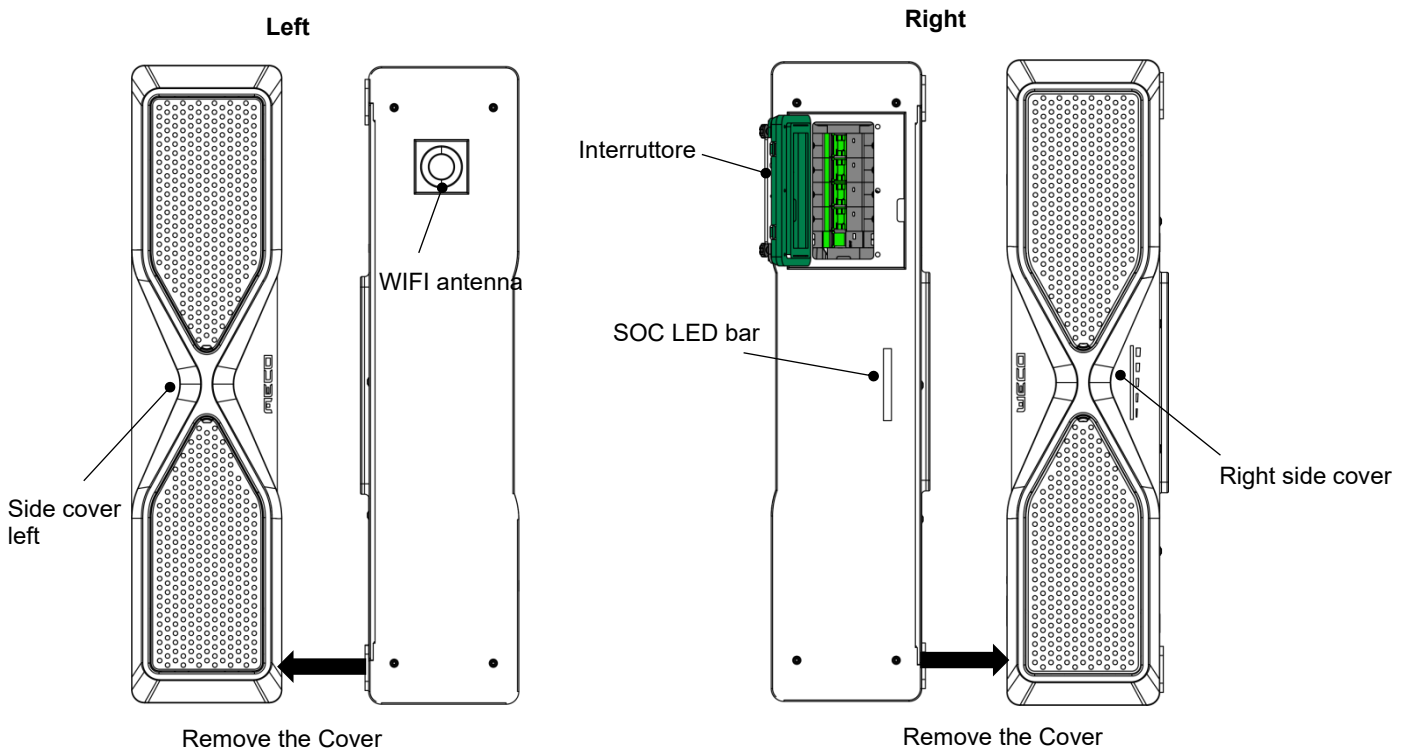

## SECTION 2 – LOW VOLTAGE CONFIGURATION

### 4. Low Voltage (LV) Configuration

#### 4.1 LV Setup Introduction

The low voltage (LV) configuration is designed for modular and scalable applications, allowing the construction of energy storage systems of different capacities and power according to the needs of the plant.

A single LV cluster can consist of up to 15 battery modules connected in parallel, managed as a single unit by the control system.

Up to 7 clusters can be connected in parallel to form large-capacity systems, resulting in a maximum of 105 modules in a single installation.

The operating voltage range of the system is 44.8 VDC to 56.8 VDC, while the maximum output current reaches 300 A. For multi-cluster configurations, the use of the LV Hub module, which manages communication and synchronization between clusters, is mandatory.

There are three ways to install the battery modules:

- **Wall mounting**, Ideal for installations in small spaces or when it is necessary to optimize the vertical arrangement of the modules. The wall mount kit is included in the standard LV battery kit (LV battery specific code) or available as a dedicated accessory.



- **Vertical ground mounting**, using the rubber pad supplied as standard inside the package. Dedicated bus bars can be used for power connections between the modules, which are available as accessories.



- **Stacked Installation**, che consente l'installazione dei moduli uno sopra l'altro per ottimizzare l'utilizzo dello spazio in altezza. Il kit per il montaggio a pila è disponibile come accessorio opzionale.



The choice of installation method must be made taking into account the load-bearing structure, the characteristics of the site and the environmental conditions. Proper installation not only ensures optimal system performance, but also contributes to its durability and overall plant safety.

#### Summary Table:

Configuration	LV	Required Accessories	Note
Wall mounting	Sì	Battery Code: B00115 or C00545	Installazione consentita solo in LV. Il kit include staffa da parete, cavi LV da 25 mm <sup>2</sup> e cavi RJ45.
Vertical ground mounting	Sì	LV: C00544	BUS BARS to be used in LV.
Stacked installation on the Base	Sì	LV: C00564 + C00544	

The choice of installation method must be made taking into account the load-bearing structure, the characteristics of the site and the environmental conditions. Proper installation not only ensures optimal system performance, but also contributes to its durability and overall system safety.

#### 4.2 Checking the Pre-Installation Accessory Set List

The battery module is packed in boxes with accessories.

Upon receipt, carefully check the list and contents of the box to ensure that the battery module and accessories have been received in the correct quantities and type, and visually inspect to ensure that they are not damaged.

If the battery is damaged and/or components are missing, contact your local WECO representative and do not proceed with the installation, photograph the product and store the battery in a safe place as prescribed.



#### ATTENTION!

Use of this product that does not follow the instructions in this document will void the product warranty. Replacement of any component of this battery module will void the product warranty. Use of any component contained in or connected to this battery module other than products sold as part of this product or recommended by the manufacturer will void the product warranty.

## 4.2.1 LV Accessories List

### 4.2.1.1 LV Battery Standard kit (specific batteri code – B00115)

Available as separate accessory kit – C00545

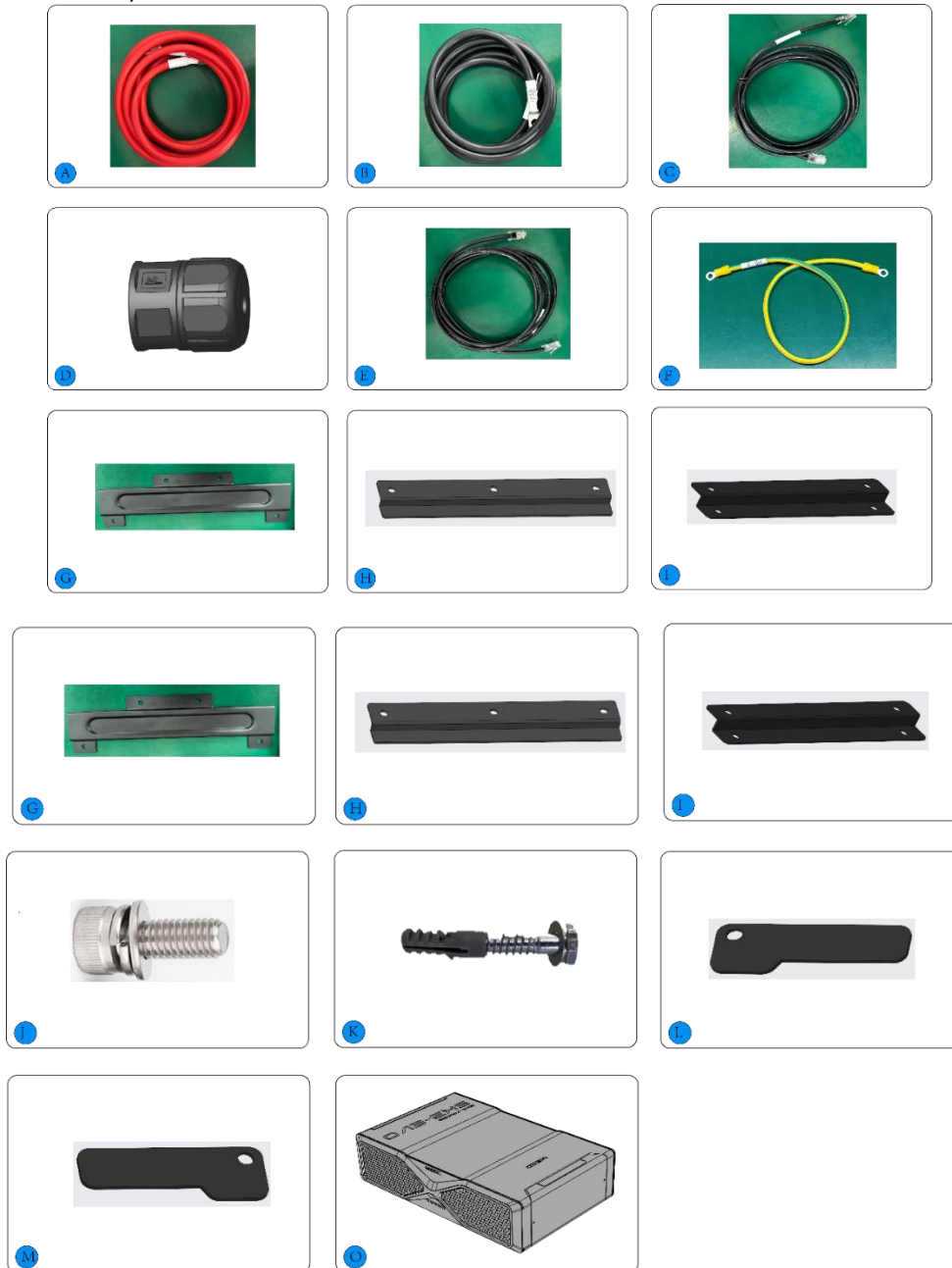

Item	Function & Description	Function &Description	QTY
A	Positive cable, battery output	Red UL10269 4AWG cable with a length of 2.5 meters, crimped with an OT terminal (SC25-8) on one end and an OT terminal (SC25-10) on the other end.	1
B	Negative Cable, Battery Output	Black UL10269 4AWG cable with a length of 2.5 meters, crimped with an OT terminal (SC25-8) on one end and an OT terminal (SC25-10) on the other end.	1
C	Inverter communication network cable	2-core communication network cable with PIN 1/2 to PIN 4/5, 2.5 meters, black	1
D	RJ45 Waterproof Plug	2-core communication network cable with 1/2 PIN to 4/5 PIN, 2.5 metres, black	2

E	Battery Communication Network Cable (Wall Type)	8-core communication network cable, 2.5 meters black	1
F	Cavo di messa a terra di uscita della batteria	2.5meter/8AWG yellow-green cable with OT terminals (HRV8-6) crimped at both ends	1
G	Wall-mounted bracket-1	2.5 meter/8AWG yellow-green wire with OT (HRV8-6) terminals crimped on both ends	1
H	Wall Bracket-2	Wall-mounted bracket-2	1
I	Staffa 2Wall Bracket Screws 1 (Box)	Bracket 2	1
J	Wall Bracket Screws 1 (Box)	Stainless Steel M6*16/304/Natural Color Passivation/72H	5
K	Wall Bracket Screws 2 (Wall)	M6×60 hex head expansion bolt	4
L	damper	Rubber Pad 140*50*4mm A	1
M	damper	Rubber Pad 140*50*4mm B	1
O	Battery Body	Battery Body	1

**4.2.1.2 LV Optional Accessory Kit – C00564**

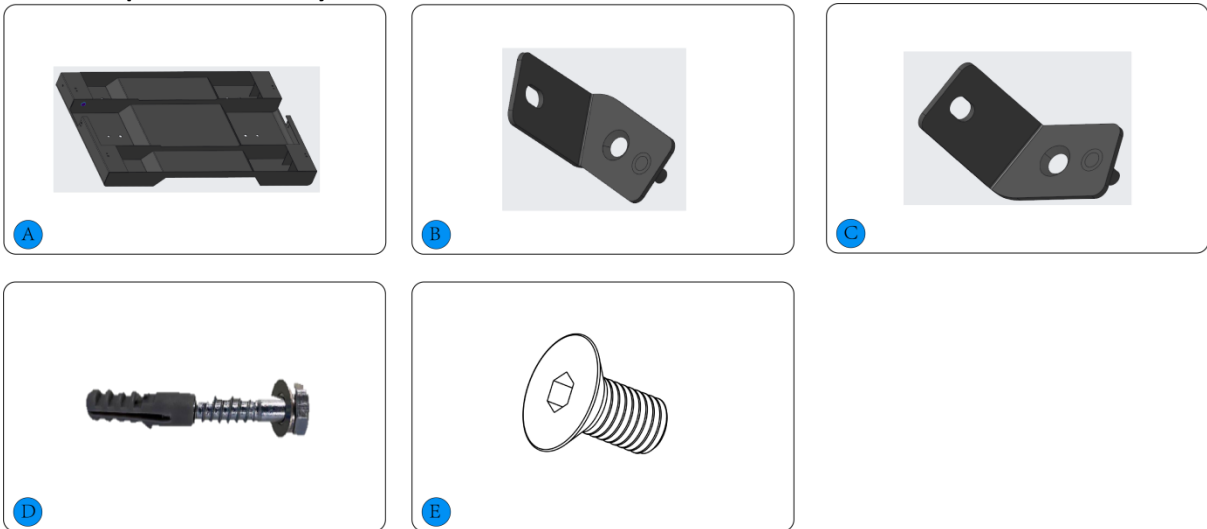

Item	Name	Function &Description	QTY
A	Base	Base	1
B	Base fixing bracket 1	Base Fixing Bracket 1, attached to the base by countersunk screws, used to secure stacked batteries, this item is installed on site by the customer as an accessory (used with the base)	2
C	Base Fixing Bracket 2	Base Fixing Bracket 2, fixed on the base with a pressure grub screw, used for fixing the stacked battery, this item is installed on site as an accessory (used with the base)	2
D	Hex Self Tapping Expansion Screw M6*60	The entire base is secured and used, and this item is installed on-site as an accessory (used with the base)	4
E	Hex countersunk screws M4*8	Fixing bracket and baffle for fixing the base ((used with the base fixing bracket 1, the base fixing bracket 2 and the baffle))	6

### 4.3 General preparation

#### 4.3.1 Installation Location

For the low-voltage configuration, the battery module must be installed in a suitable location in accordance with the instructions in this manual. Installation in a plant room is the optimal solution, as it ensures controlled environmental conditions, with minimal temperature fluctuations, adequate ventilation and the absence of humidity and condensation.

However, outdoor installation is possible, provided it is in a covered area not exposed to direct sunlight, in a well-ventilated location that ensures environmental conditions that are as stable as possible, with limited temperature fluctuations.

In all cases, the batteries must be installed in dry, well-ventilated environments, maintaining the temperature within the limits specified in the warranty conditions. The installation and operating conditions must also comply with local regulations and the international, national and regional standards applicable to lithium-ion batteries.

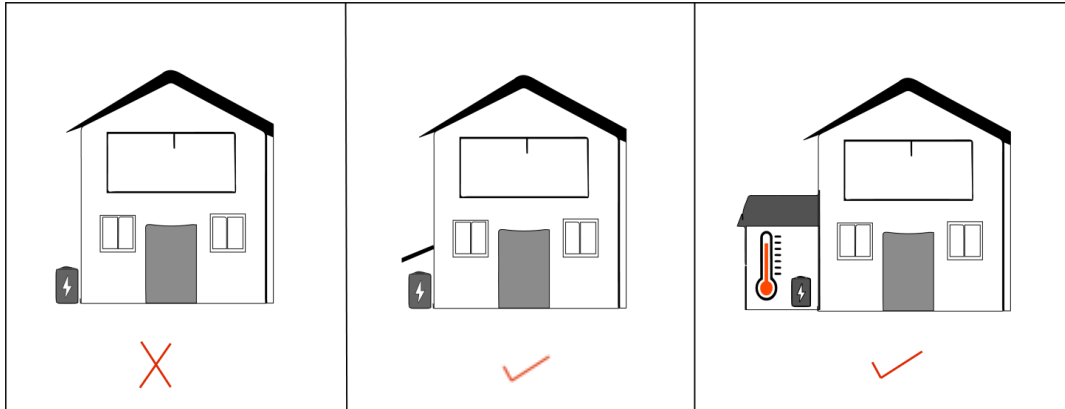

The distance between the system and surrounding objects must meet the following conditions: left and right distance  $\geq 500$  mm; Upper distance  $\geq 300$  mm; Distance less  $\geq 500$  mm; The distance should be  $\geq 500$  mm to ensure sufficient space for installation and heat dissipation.

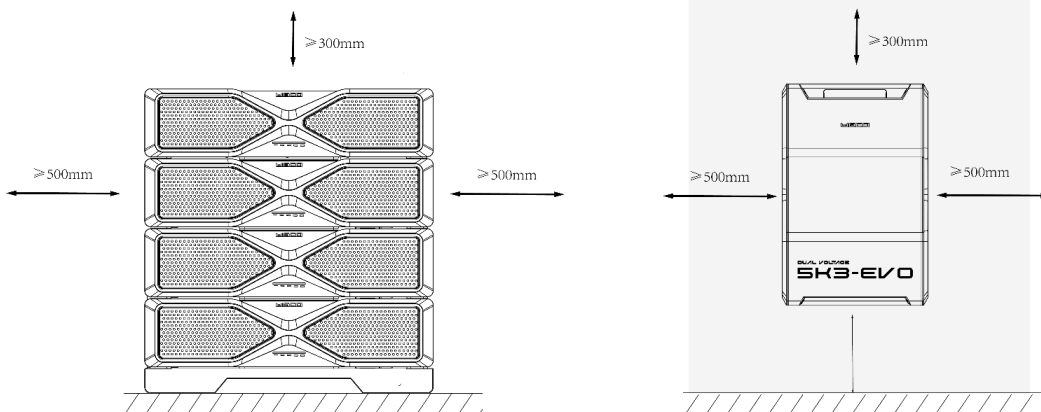

\*When using accessory covers, LV terminals have an IP64 protection rating and can therefore be installed in environments that comply with this standard.

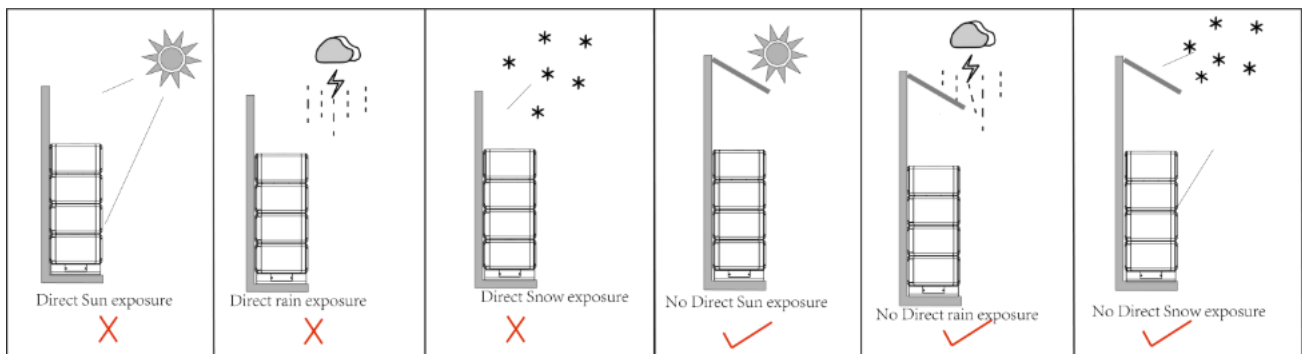



**Warning!**

Make sure all modules are turned off. Make sure the environment is clean, keep away from water sources such as faucets, sewers, sprinklers, etc., to avoid water infiltration.

Make sure the enclosure is free of damage, dents, or deformation caused by impact.

The place where the battery is installed should be away from heat sources, protected from any source of fire, open flames and any other source of extreme temperature.

The battery connection cables should be as short as possible to prevent excessive voltage drops.



Battery installation should be away from gas, fuel, or flammable gases or liquids. Internal electronic devices may cause internal sparks during normal use.

Before connecting the battery, you should check the positive and negative terminals of the battery to ensure proper installation.

The installation location must be suitable for the weight and size of the battery system.

**4.3.2 Installation Tools**

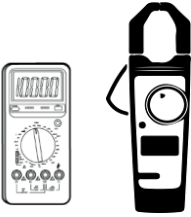
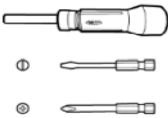
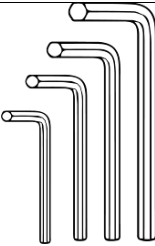
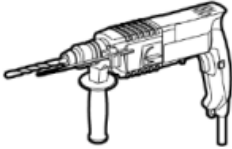
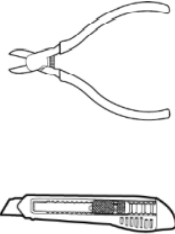
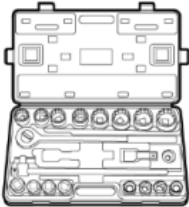
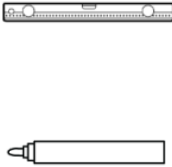
Based on the different installation methods, installing this battery system will require the use of all or part of the following tools:

 <p>Multimeter + Clamp Meter</p>	 <p>Insulated screwdriver set</p>	 <p>Set of insulated Allen keys from 2 mm to 8 mm</p>	 <p>Drill + Hammer</p>
 <p>Electricians' scissors and knife</p>	 <p>Insulated torque wrench set</p>	 <p>Horizontal ruler + markers</p>	 <p>Equipment for security personnel</p>

**Torque requirements**

When using screw tightening (bolt), all connecting fasteners must meet the torque or clamping force and must not experience plastic deformation, cracks or breakage.

**Screw tightening torque table**

Screw type	M3	M4	M5	M6	M8	M10	M12	M16
(N*m)	0.7-1	1.8-2.4	4-4.8	7-8	17-20	34-40	60-70	119-140

#### 4.4 Install the battery module



ATTENTION!

There is a risk of injury due to the weight of the battery module if the battery module is lifted incorrectly or dropped during transport or installation.

- Carefully lift and install the battery module.
- Wear appropriate personal protective equipment for all work on the battery module.

The installation operation must be carried out by a qualified personnel

The battery is always delivered in wall mode, so it is necessary for the installer to make it simple. Changes to the installation of modules. Below are the installation steps.



ATTENTION!

The battery has two square-shaped handles, which can be moved by two people.

Before starting any operation on the battery, be sure to place the modules in their final position and structurally fix all the modules that make up the system on a previously verified surface.

##### 4.4.1 Wall Installation

###### Procedure

###### Step 1: Install the wall bracket.

Check and make sure the wall is appropriate.

Place the bracket on the wall and use the level indicator to make sure the levelness of the bracket.

Use a marker to mark the location of the holes.

Drill holes with a  $\Phi 8$  mm drill.

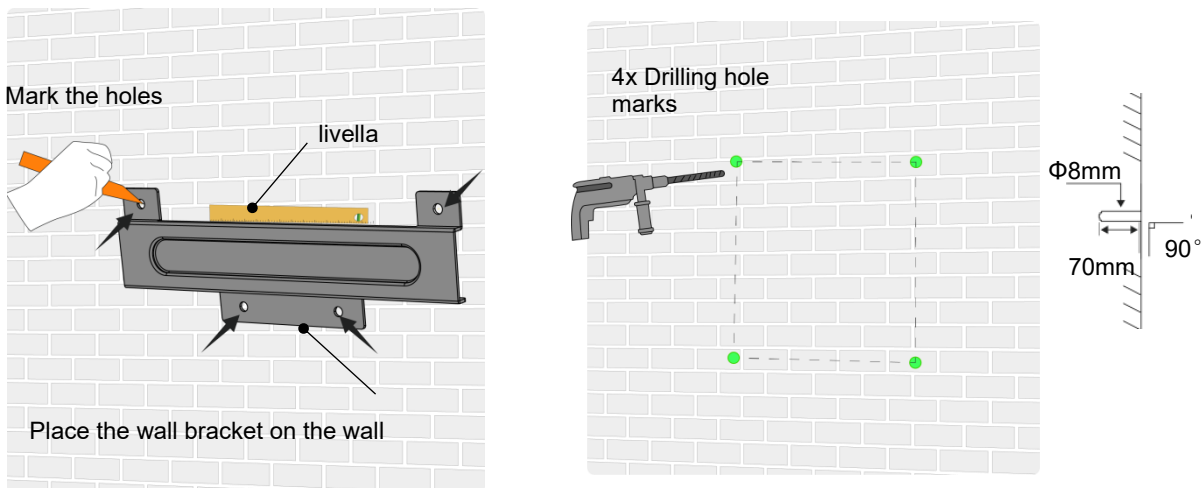

Install the bracket.

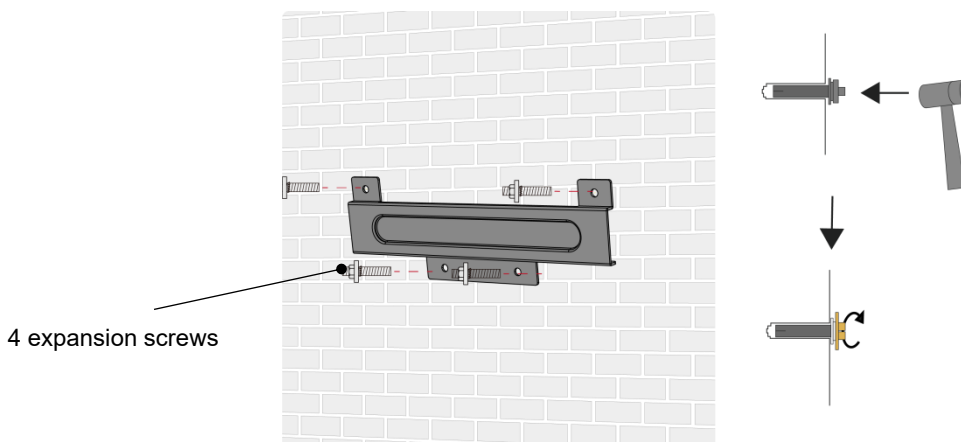

**Step 2: Attach the battery bracket 1 and bracket 2 to the back side of the battery module.**

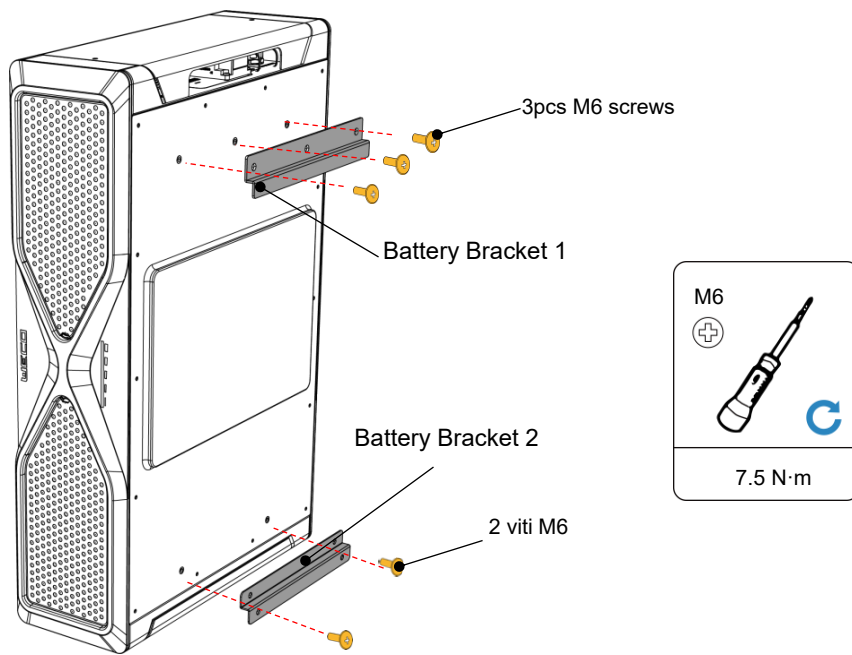

**Step 3: Remove the side grates to better lift the batteries to hang on the wall.**

Use a flat screwdriver to open the grates as follows.

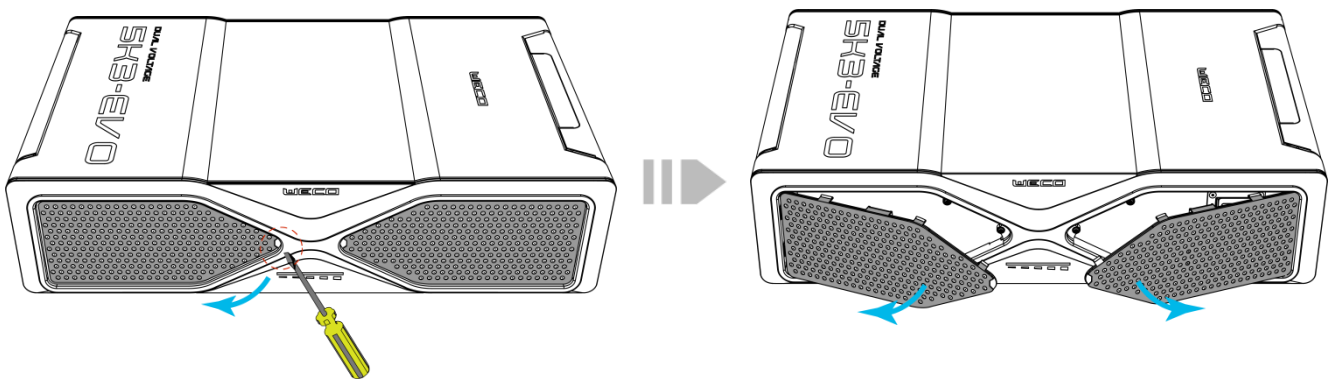

After removing the grilles, find the handle on the left side of the battery.

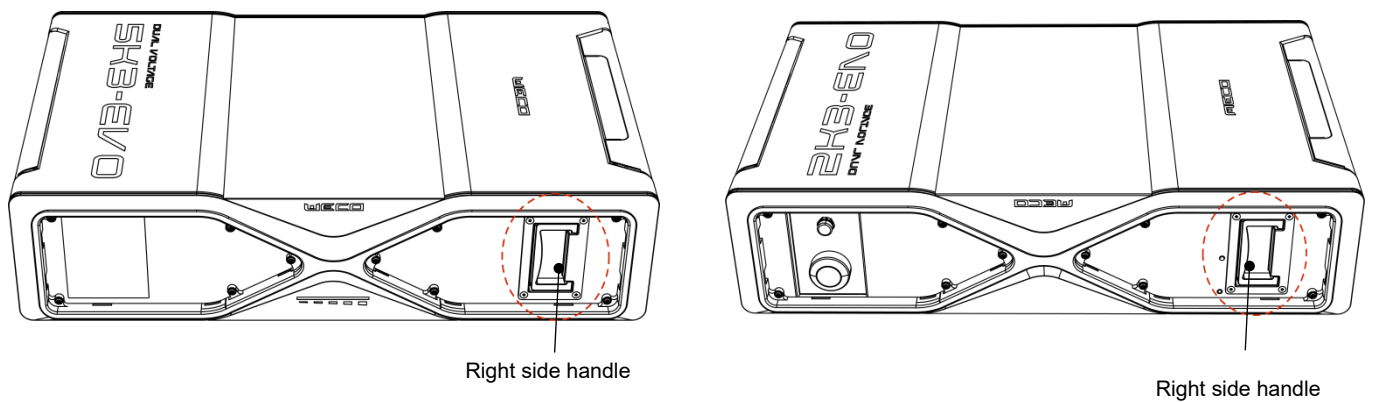

**Step 4: Hang the battery on the wall bracket attached to the wall.**

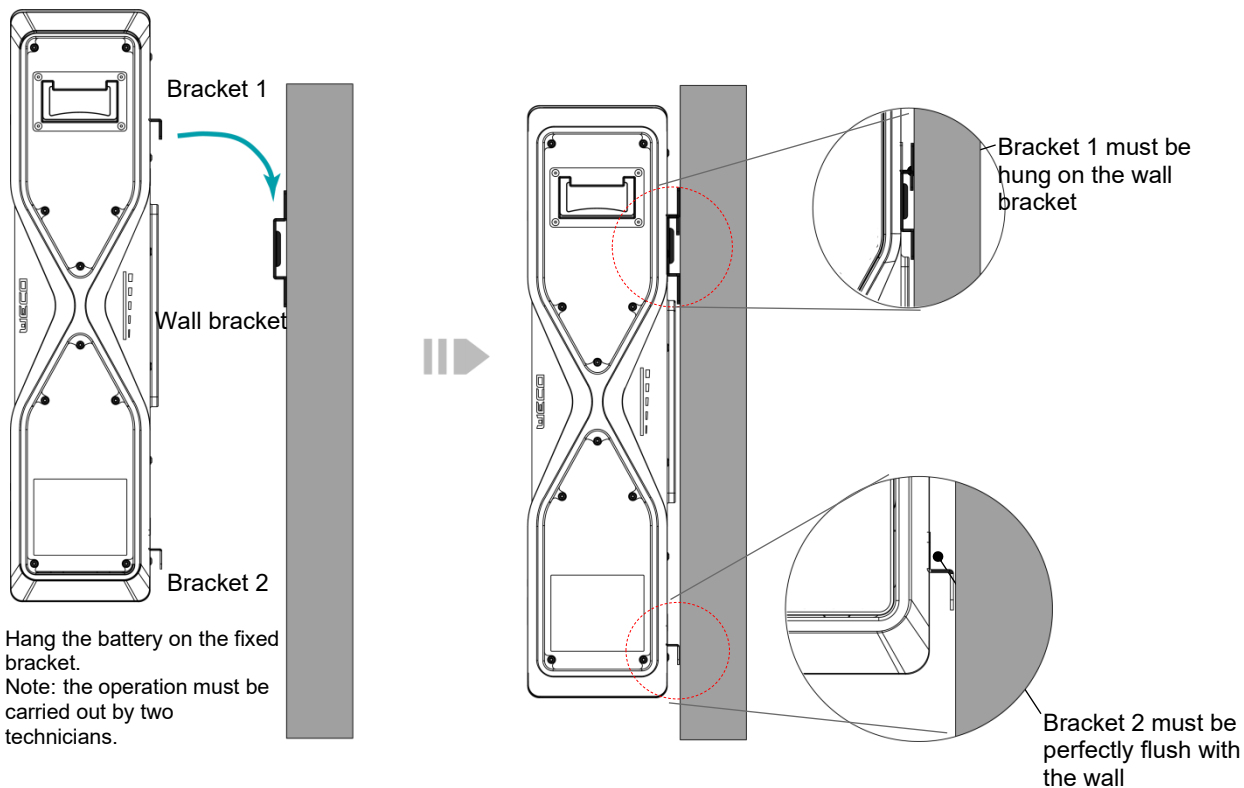

**4.4.2 Stacked installation**

**Step 1: If the batteries need to be stacked, you don't need to install the rear brackets, remove the brackets if pre-installed.**

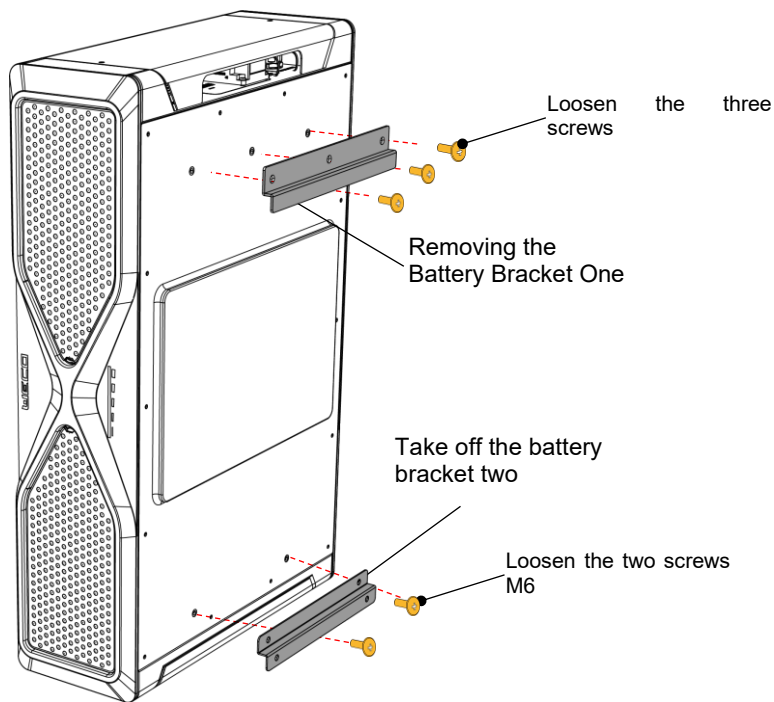

### Step 2: Install the base.

Place the base on a solid support and verified by a qualified civil engineer, the weight of one or more batteries could modify the statics of the supports and cause damage to structures and / or people.

Use a level to ensure the flatness of the base on the stand.

Mark the base mounting holes with a marker and drill with a hammer drill.

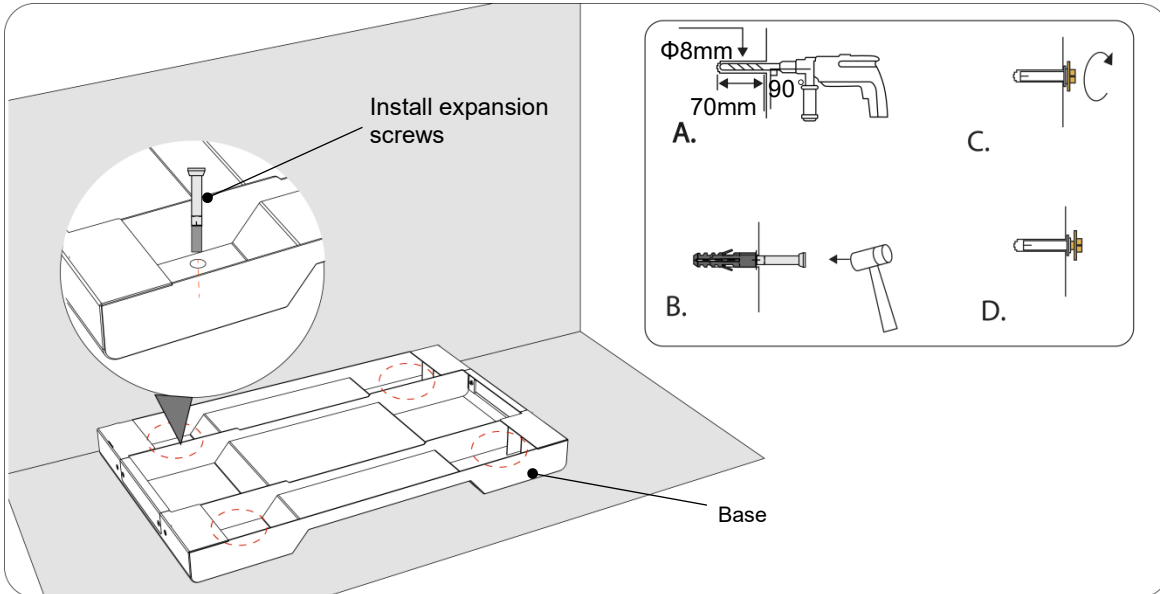

### Step 3: Remove the battery covers as follows.

Remove the top cover.

Remove the top side cover.

Remove the bottom cover/BMS.

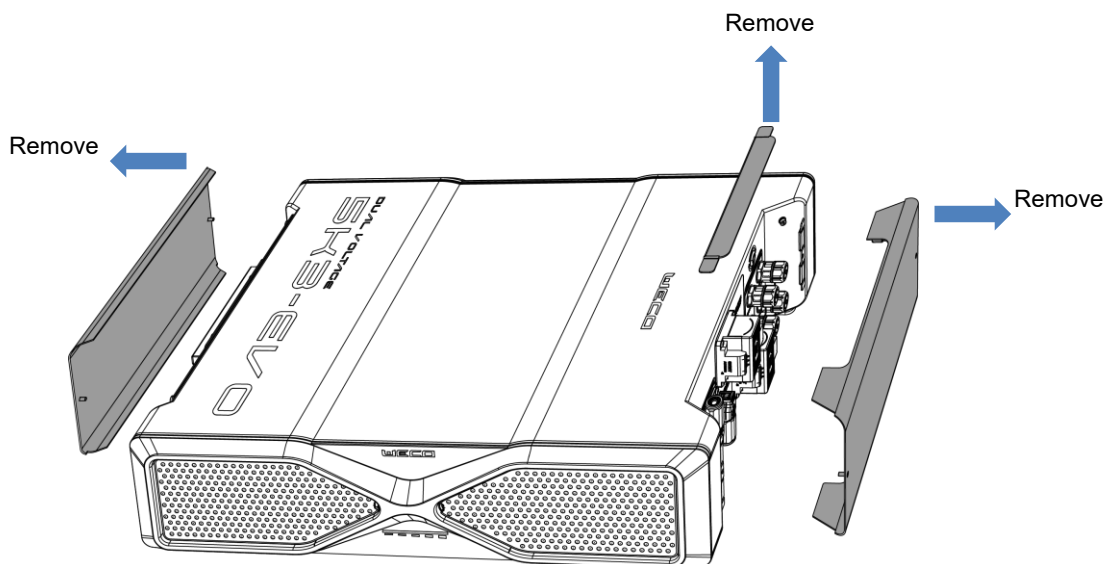

#### Step 4: Attach the pads to the back side of the battery.

If not already installed, place the insulating pads on the base of the battery.

Attach the pads to the four corners of the back side of the battery (pay attention to the different shape and position of the rubber pads)

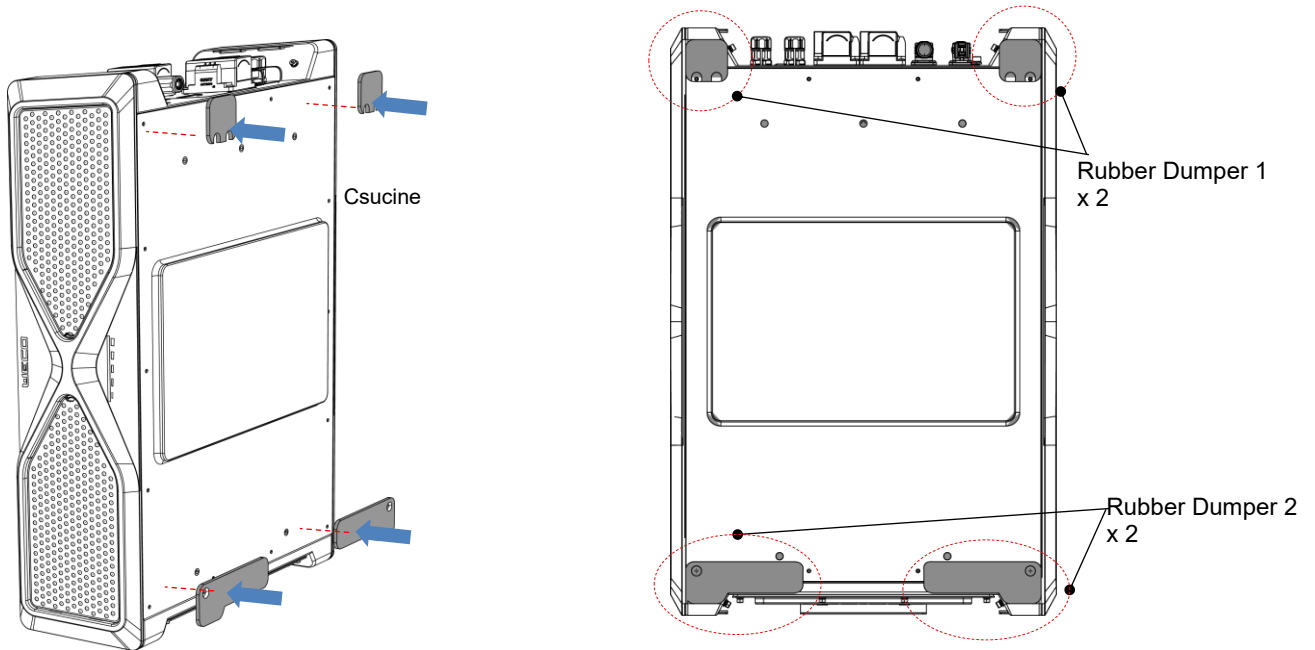

#### Step 5: Stack the battery modules.

Stack the first battery module on the base.

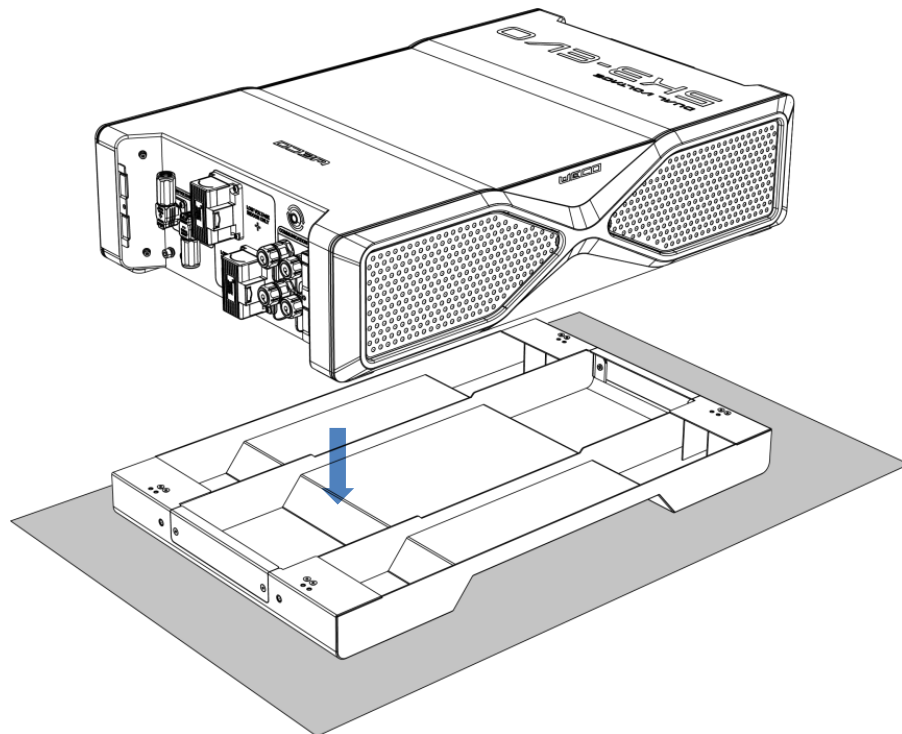

Tighten the stacked modules between the first battery module and the base with the appropriate brackets

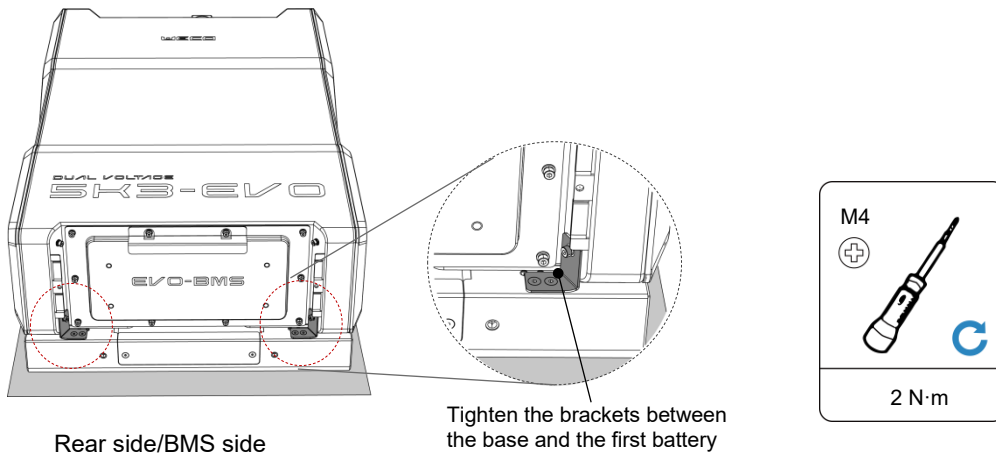
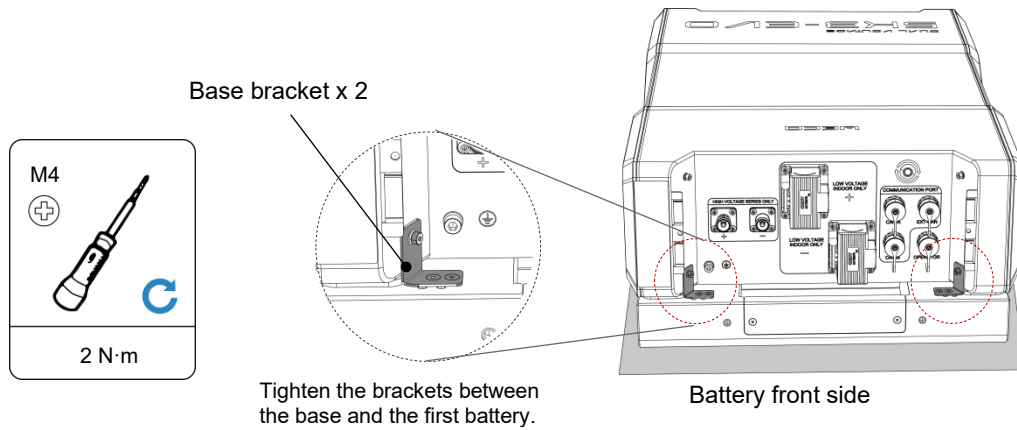

Stack the second battery module on the first battery module and tighten the 4 stacked pieces between the first and second battery modules as follows.

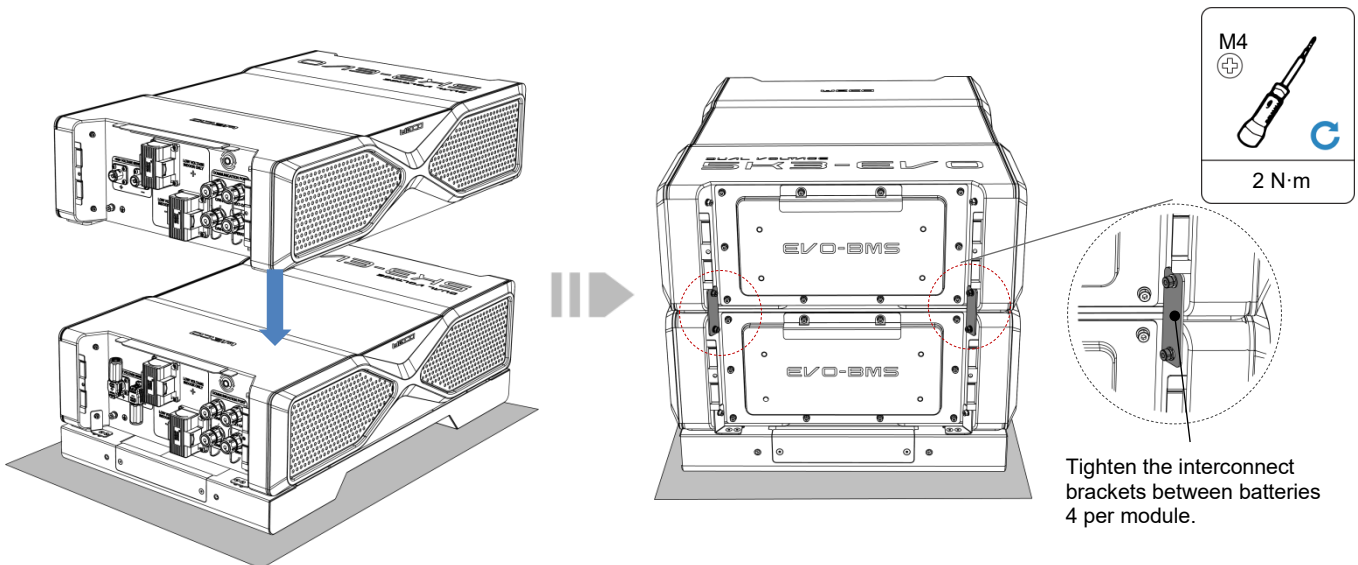

Repeat the above steps and stack the rest of the battery modules (max. 9 batteries physically stacked per base).

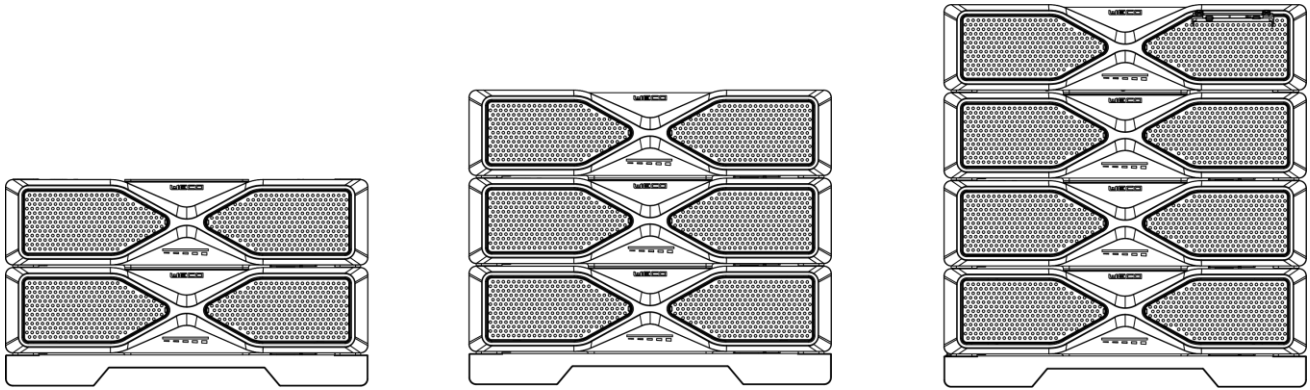

A cluster can consist of up to 15 batteries, it is important not to exceed 15 batteries for a LV cluster.

**ATTENTION**  
**Important Notice**



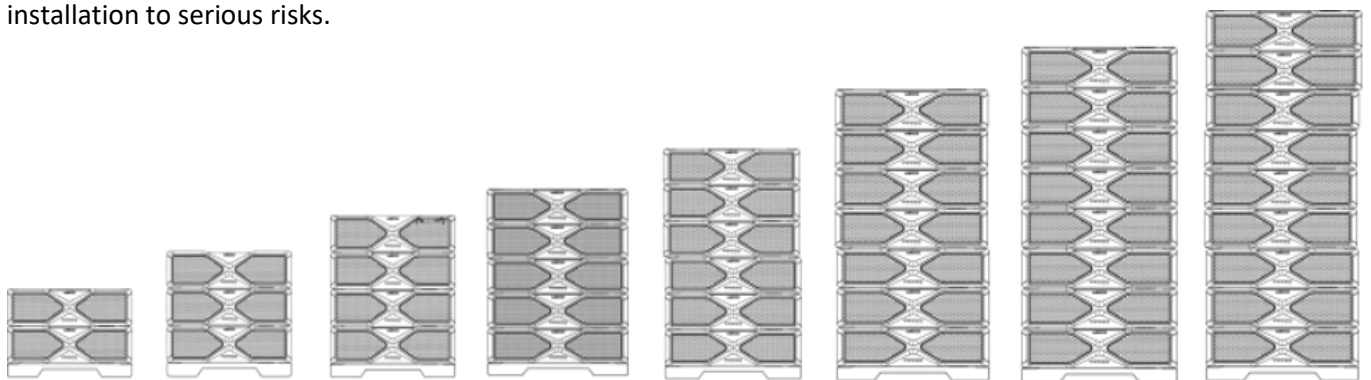

Installation of stacked battery modules must be carried out accurately and in full compliance with safety procedures. Each module must be carefully placed on top of the previous one, and the fixing brackets between the modules must be properly tightened to ensure structural integrity. Once the stack is complete, the cluster must be firmly attached to the wall to avoid any risk of tipping over or moving caused by accidental vibration or shock.

Before the system is declared safe, the support floor must be checked again by a technician to confirm that it can withstand the full load of the stacked modules, taking into account the necessary safety margins. If reinforcement is needed, it must be applied before the operation. Equally important, the installation room must be protected from the risk of flooding, ensuring that water cannot reach the base of the battery modules under any circumstances.

Only when the modules are correctly stacked, the cluster anchored to the wall, the floor capacity verified and adequate protection against water ingress is ensured, can the system be considered safe for use. Failure to comply with these conditions can compromise structural stability and electrical safety, putting a strain on the installation to serious risks.



## 4.5 Electrical connection

 Danger	The voltage at the conductive end of the battery is dangerous. When installing the battery module, it is forbidden to touch the positive and negative poles directly with your hands Before performing electrical operations, make sure everything is in order and free of damage
 Notice	Static electricity can damage the battery's electronic components. Anti-static measures must be taken during installation and maintenance. Ground the base and each battery during installation
 ATTENTION!	Do not use terminals or connectors of other brands or types other than those found in the accessory package.
 ATTENTION!	Moisture and dust can damage the battery, please make sure the cable connectors are clean and tightened securely during installation.

### 4.5.1 Instructions for Electrical Connection of a Low Voltage Battery

#### Instructions for Electrical Connection of a Single Battery (Low Voltage Mode, 48/51.2 V)

##### 1) Preliminary safety (mandatory)

Qualified and authorized personnel only.

- PPE: insulating gloves, goggles/visor, safety footwear; DPI arc-flash where applicable.
- LOTO: Apply Lock-Out/Tag-Out on AC, PV/DC network, and any auxiliary source.
- No voltage: With CAT III/IV multimeter, check  $\approx 0$  V at the battery and inverter terminals before touching conductors or connectors.
- Prohibitions: DC hot-plug prohibited, use of non-approved components, work on live parts.

##### 2) Wiring requirements (before connections)

- DC cable cross-section: size for nominal current + thermal margin, voltage drop  $< 2\%$  on the inverter battery  $\leftrightarrow$  section.
- Bend radius:  $\geq 8 \times$  cable diameter (unless further specifications are specified).
- Cable lugs/lugs: crimping with certified tool; no exposed braid; any compliant ironwork.
- Tightening torques: Only follow the official table in the 5K3 EVO manual.
- Paths: Separate power and signal; strain-relief fixings; anti-abrasion cable glands/sheaths.
- Terminal protection: provide terminal covers and rubber/silicone protections (if supplied).
- EMC: Single-sided earthed shields (typically inverter side).

##### 3) Link (binding order)

1. **PE / Equipotential**
  - a. Connect the **protective conductor (PE)** inverter battery  $\leftrightarrow$ .
  - b. Measurement of PE continuity ( $< 0.1 \Omega$  typical short section; acceptance according to standard/instrument).
2. **Battery inverter  $\leftrightarrow$  communication (EXT-CAN)**
  - a. Connect **EXT-CAN** between inverter BMS port and battery CAN port.
  - b. **Terminations**: if provided, ensure **120  $\Omega$**  at the ends of the backbone (measurement between CAN-H/CAN-L when the system is disconnected  $\approx 120 \Omega$  or **60  $\Omega$**  if double internal termination).
3. **Battery-to-battery communications (if required)**
  - a. Connect **CAN A/CAN B** according to the manufacturer's diagram; avoid rings; length within limits.
  - b. **Screen**: Ground on one side; no flying leads.

#### DC Power Connections

- Check **polarity** with multimeter before pairing: red (+), black (-).
- Connect **the negative (-)** battery → inverter; tighten to the **prescribed torque**.
- Connect **positive (+)** battery → inverter; torque tighten.
- Install (if provided) **DC disconnectors/switches/fuses** between the battery and the inverter and **leave them CLOSED** before starting (see pre-charging).
- Apply **rubber/silicone terminal covers and protections (dust/oxide/water reduction)**.

#### Connection to the inverter (inverter off)

- Connect to the terminals according to **the manufacturer's instructions** (stripping lengths, plates, washers).
- **Configuration:** Select correct **battery profile/protocol**; intended addresses, baud-rate, and logic.

#### 4) Pre-ignition verification (instrumental checks)

- Tightening: check with a torque wrench (record values).
- Cable integrity: no cuts, crushing or lower radii; absence of chips/foreign bodies.
- Insulation (if required by the system procedure): low voltage megger test suitable for the system (avoid excessive stress on electronics) or IR test according to the system test chapter.
- CAN: Measures termination resistance ( $\approx 120/60 \Omega$  as above), continuity and RJ45 pinout.
- Voltages: confirm 0 V at the operating points before starting; Check that the battery is in the expected no-load range.

#### 5) Commissioning (mandatory pre-charging)

- Close any DC disconnectors/switches between the battery and the inverter.
- Turn on the battery → enables the inverter's DC-link pre-charging.
- Turn on the inverter.
- Check on HMI/APP: OK communication, SOC, voltage/current, temperatures, no alarms.

#### Warning

**Pre-charge:** If the switches between the battery and the inverter **are not closed** before the battery starts, the **pre-charge will not operate** and there is a risk of **damage** to the battery and/or inverter due to uncontrolled inrush currents.

#### 6) Acceptance criteria

- Measurement of continuous earth, resistance within limits; no active alarm; consistent V/I/SOC readings; no polarity reversal; specific torques; Stable CAN without errors; Intact and protected connectors.
- In case of non-compliance: stop, secure, correct, re-inspect and document before recommissioning.

#### 7) Traceability

- Record: date/time, operators, S/N battery/inverter, diagram used, applied torques, measurements (PE, CAN TERMINATION resistance, V/I), configured parameters, photos.
- Attach screenshots/logs of the APP and LOTO report.

#### Note

The connection diagram is shown in the following figure.

Follow the instructions carefully to ensure safe and correct connections.

The final verification and switching on of the system must be carried out exclusively by a qualified technician, following the testing procedure and the verification of electrical conformity of the system according to current standards.

#### Regulatory compliance clause

These instructions must be applied in compliance with the **laws, regulations and technical standards in force in the country of installation**, including (but not limited to) the standards for LV systems (**IEC/EN 60364** and national transpositions), safety/performance of batteries and storage systems (**IEC/EN 62619**, **IEC/EN 62933** where relevant), grid connection requirements (e.g. **CEI 0-21/0-16** or local equivalents), **IP/IK degrees of protection** and any prescription of the competent authority and the local distributor. In the event of a discrepancy, **local regulations shall prevail**; the installer must adapt the design, execution and documentation and **demonstrate compliance**.

## 4.5.2 Single battery connection in low voltage data/signals and checks

### Procedure:

#### Single low voltage battery connection (46/57.8 V)

##### Prerequisites

- Qualified personnel, PPE (insulating gloves, goggles/visor).
- Inverter switched off and isolated from grid/PV; battery off.
- Dimensioned cables (cross-section/insulation), crimped cable lugs, tightening torques according to datasheet.
- Procedure (
- Grounding (PE). Connect the PE protective conductor between the battery and the inverter; verify continuity of the equipotential bond.

##### CAN Communications.

- Connect the EXT-CAN cable between the inverter and the battery.
- If the system provides it, connect CAN A / CAN B between modules (not necessary for single battery if not required).
- Terminations: ensure 120  $\Omega$  resistors at both ends of the CAN backbone (only where provided).
- Shielding: Connect the shield to the ground of the CAN cable from one side only (typically inverter side).

##### DC – Power connections.

- Check polarity and tightening.
- Connect the negative (-) battery → inverter.
- Connect positive (+) battery → inverter.
- Insert DC disconnect switch/switch and fuses according to local code (if required).

##### Settings.

- Select the correct battery protocol (brand/model) in the inverter.
- For single battery: address = 01 (or expected default), CAN baud rate as per specification.

##### Messa in servizio

- Close any DC switches/disconnectors between the battery and the inverter.
- Turn on the battery (allows pre-charging of the inverter's DC capacitors).
- Turn on the inverter.
- Check OK communication (SOC, voltage, current) and no alarms.

#### **WARNING – Pre-Charge**

If there are switches/disconnectors between the battery and the inverter, they must be CLOSED before starting the battery. Otherwise, the inverter's pre-charge function will not operate and you may damage the battery and/or inverter due to uncontrolled inrush.

##### Prohibitions and Final Notes

- DC "hot-plug" with the system on is prohibited.
- Observe tightening torques and check again after 15–30 min.
- Cable routing: separate power and signal; avoid ground loops that can destroy the signal

**ATTENTION:**

DC breaker to be added in accordance with the local regulations, in case a DC breaker is added **do not turn the battery ON** if the breaker is open as **this will damage and make useless the pre-charge function** to the inverter

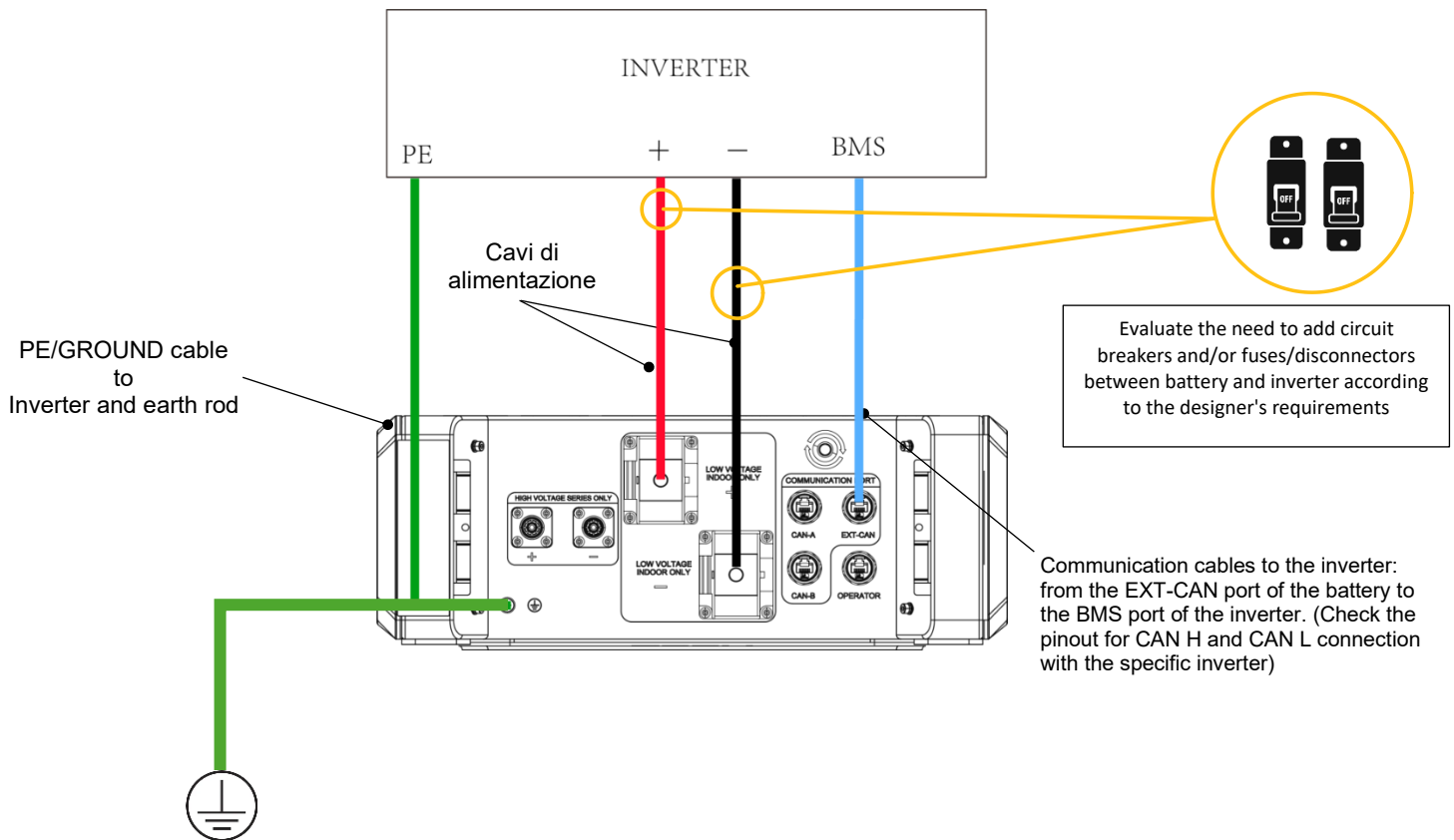

**BUS BAR (LV) Kit Requirements**

Field of application: low voltage battery/inverter connections (48/51.2 V).

**1) Supply and Compliance**

- If an LV BUS BAR is required, it must be ordered directly from WeCo: only the use of the approved WeCo BUS BAR and its accessories is permitted for installation.
- The WeCo LV BUS BAR Kit includes the bus bar and a set of rubber/silicone protectors designed to reduce the risk of dirt, oxidation, and water/dust deposit on the battery terminals and junction points.

**2) Installation and protections**

- Assemble the BUS BAR LV according to the tightening torques and instructions provided by WeCo.
- Fully apply the rubber/silicone protections (headphones/boots, joint covers, screw covers) ensuring:
  - Complete adhesion on terminals and surfaces at risk of deposit.
  - Absence of cracks that could favor the entry of dust or drops of water.
- Keep the power and signal paths separate; Avoid stagnation points and create, if possible, a cable drip to limit the migration of liquids to the terminals.
- Do not remove or modify guards, their integrity is part of the security requirement.

**3) Environmental restrictions (mandatory)**

- Rubber/silicone protectors are additional and are not a substitute for the requirement of a properly protected site.
- The system should be installed in a sheltered area, not exposed to direct rain, spray, suspended dust, corrosive atmosphere, or persistent condensation.

**⚠ Important:** even with the protections installed, the site must guarantee environmental levels that comply with the prescriptions of the manual as well as the conditions of ventilation and shielding from water, sun and temperatures beyond the permitted limits. The protections do not make the assembly suitable for outdoor installations, the battery must still be protected and shielded

**4) Maintenance/Inspections**

- Carry out periodic inspection: check the integrity of the protections, absence of dust/humidity, absence of oxidation on the terminals.

- In case of contamination: de-energize, remove the protections, clean and dry the surfaces, restore the protections by checking the adhesion.
- Record any anomalies (photos, serial numbers, date, intervention performed) as a report.

#### 5) Prohibitions

- It is forbidden to use BUS BAR or non-WeCo or non-compliant protections.
- It is forbidden to operate on live connections (no hot-work); Follow LOTO procedures.
- Do not work that punctures/cuts the protections or reduces their coverage.

#### CAUTION – LV BUS BAR KIT:

use only BUS BAR and approved WeCo protections. Rubber/silicone protectors reduce dirt/oxidation/splashing but are not a substitute for the requirement to install the battery in an area protected from precipitation, dust and splash water. Failure to comply with environmental conditions can shorten service life and increase operational risk.

### LV KIT Silicone Protector (ACCESSORY to be purchased separately) Installation Procedure

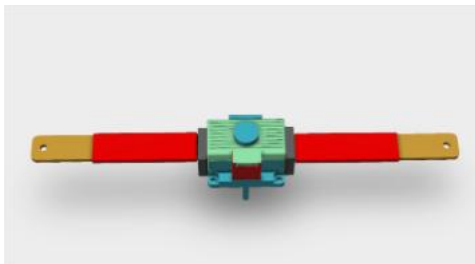

The silicone protector is necessary to ensure that water or dust does not infiltrate the battery terminals but does not guarantee the total waterproofing of the system.

Two **types of silicone protectors are available:**

**Busbar Type:** Designed for connections with flat busbars.

**Cable Type:** Designed with a pre-cut round routing for output cables.

Follow the correct procedure depending on the type of connection.

#### A. Busbar installation

**Identify the correct silicone guard** (busbar type).

**Place the silicone protector** on the terminal.

**Insert the first busbar** into place through the silicone protector.

**Add the second silicone protector** on the opposite side and slide the bar through it.

**Push both silicone protectors firmly** until they touch the dent/outer shoulder of the terminal.

**Secure the busbar** by tightening the screw provided.

**Adjust the protective tabs** to the correct position.

**Place the screw cover** over the remaining screw hole and press firmly until it locks.

**Close the terminal cover** with constant pressure.

**Press down on the silicone lid** to make sure all slots are sealed.

**Repeat for both** the positive and negative terminals.

#### B. Installation with output cable

**Identify the correct silicone protector** (cable type, pre-cut round routing).

**Insert the output cable** through the pre-cut opening of the silicone cover.

**Place the silicone protector firmly** on the terminal.

**Secure the cable lug** with the screw provided.

**Adjust the protective tabs** to the correct position.

**Place the screw cover** over the screw hole and press firmly until it locks.

**Close the terminal cover** with constant pressure.

**Press down on the silicone lid** to make sure all slots are sealed.

**Repeat for both** the positive and negative terminals.

**Important Note:**

Even with silicone guards and busbar/cable covers installed correctly, the **battery should be installed in a shaded area, protected from precipitation, water splashes, and dust.**

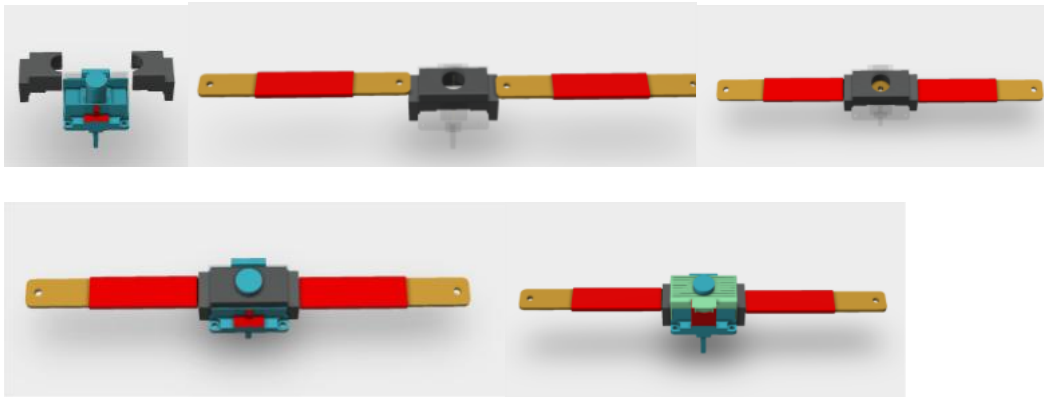

**4.5.3 Parallel Battery Connection Diagram**

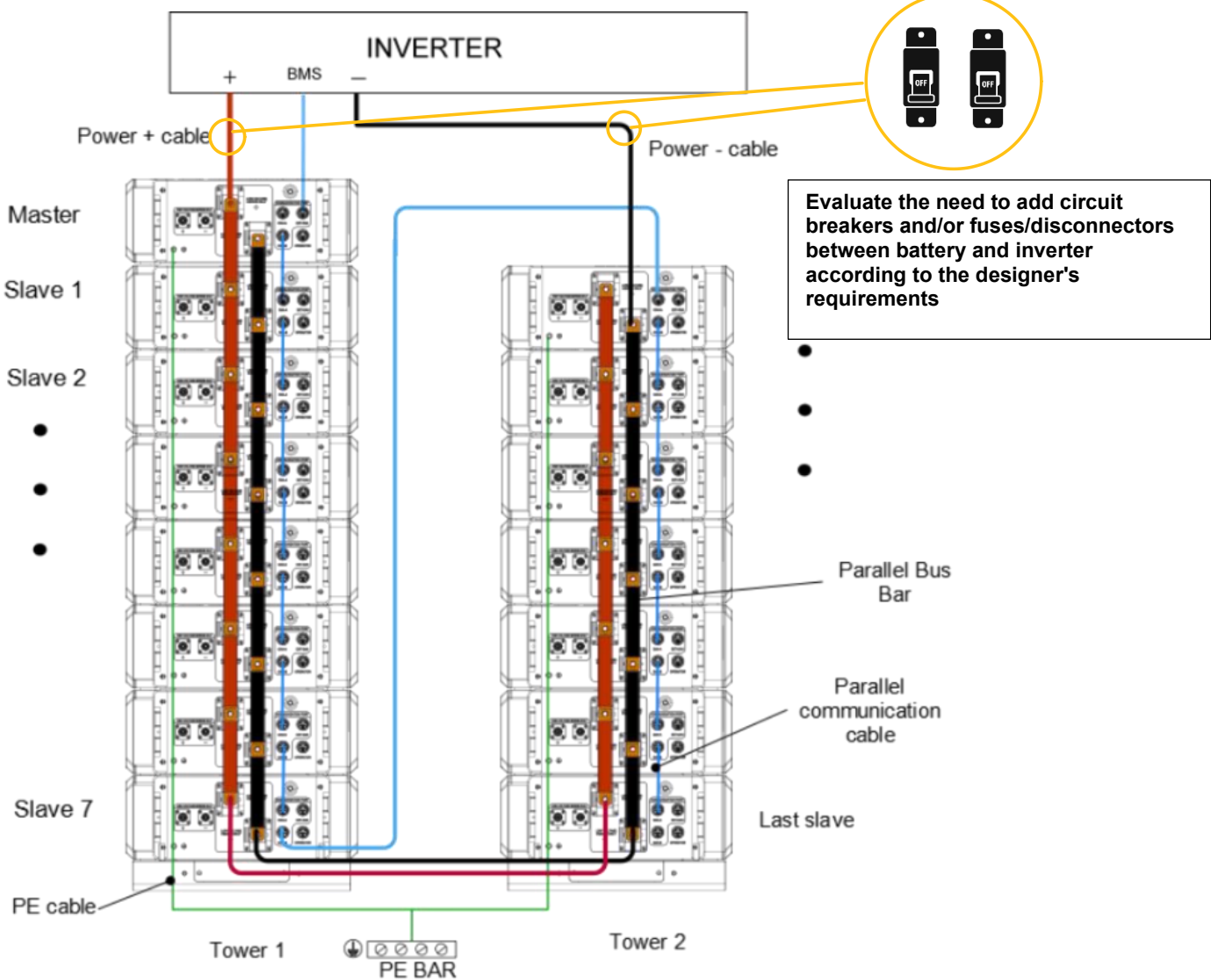

**Procedure:**

**Procedure for connecting batteries in parallel**

**⚠ Safety Warning:**

Before commencing any connections, ensure that all equipment is switched off and disconnected from the mains supply. Use a tester to verify that the voltage at the battery and inverter terminals is 0V to avoid the risk of electric shock or blown fuses.

**Step 1: Connecting the protective conductor (PE)**

- Connect the ground (PE) cable of each battery together.
- Connect the PE cable from the battery pack to the inverter.
- Connect the earth of the battery modules to the ground pole of the building, after measuring and validating the resistance
- This step ensures that all grounds are grounded and grounded, reducing the risk of accidental discharge or short circuit.

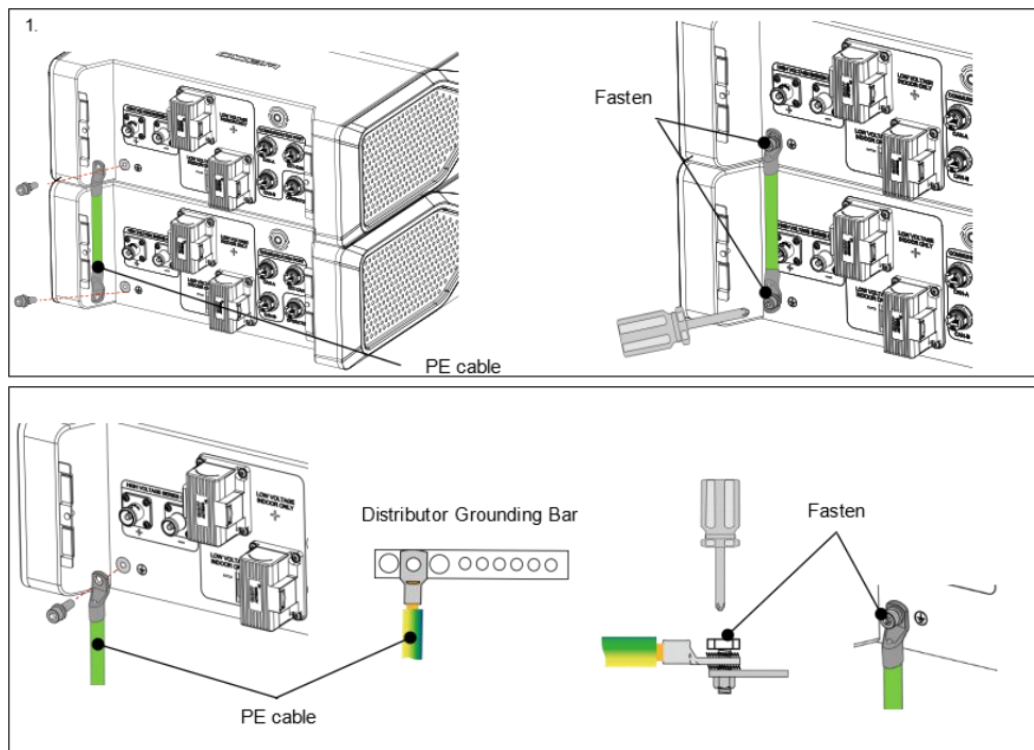

**Step 2: Connecting the communication cables between the batteries**

Connect the parallel communication cables following the sequence:

CAN B of the master battery → CAN A of the slave battery 1

CAN B of the Slave 1 battery → CAN A of the Slave 2 battery

Continue with the same logic for all connected batteries.

If provided by the system, terminate the communication line with the termination resistors according to the specifications in the manual.

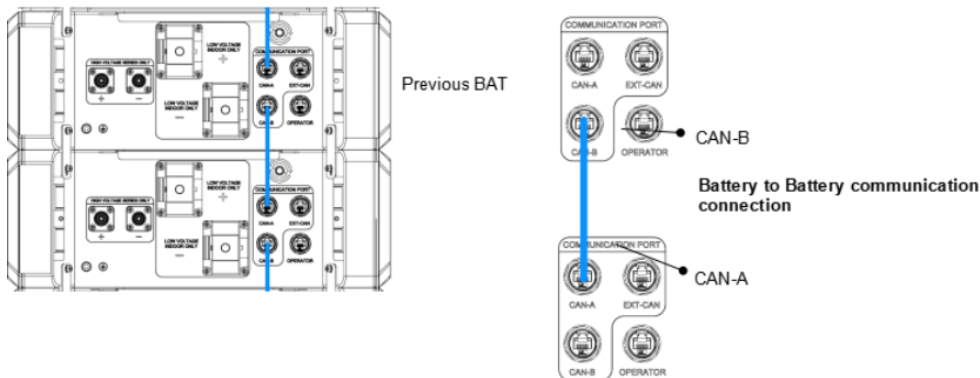

**Step 3: Connecting the communication cables between the battery and the inverter.**

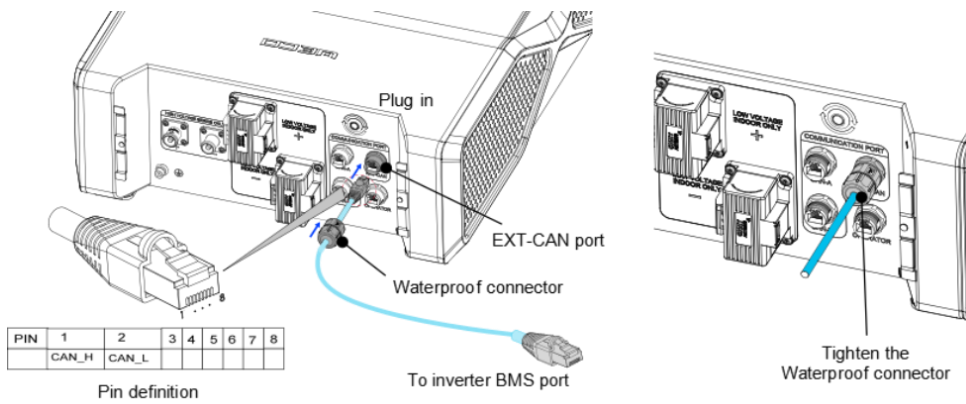

**Step 4 – Connecting the Parallel Bars (Busbars)**

Connect the parallel bars on the positive (+) and negative (-) terminals of the batteries. Tighten the connections according to the tightening torques specified in the technical manual. Make sure that the conductors and bars have no play and are free of oxidation.

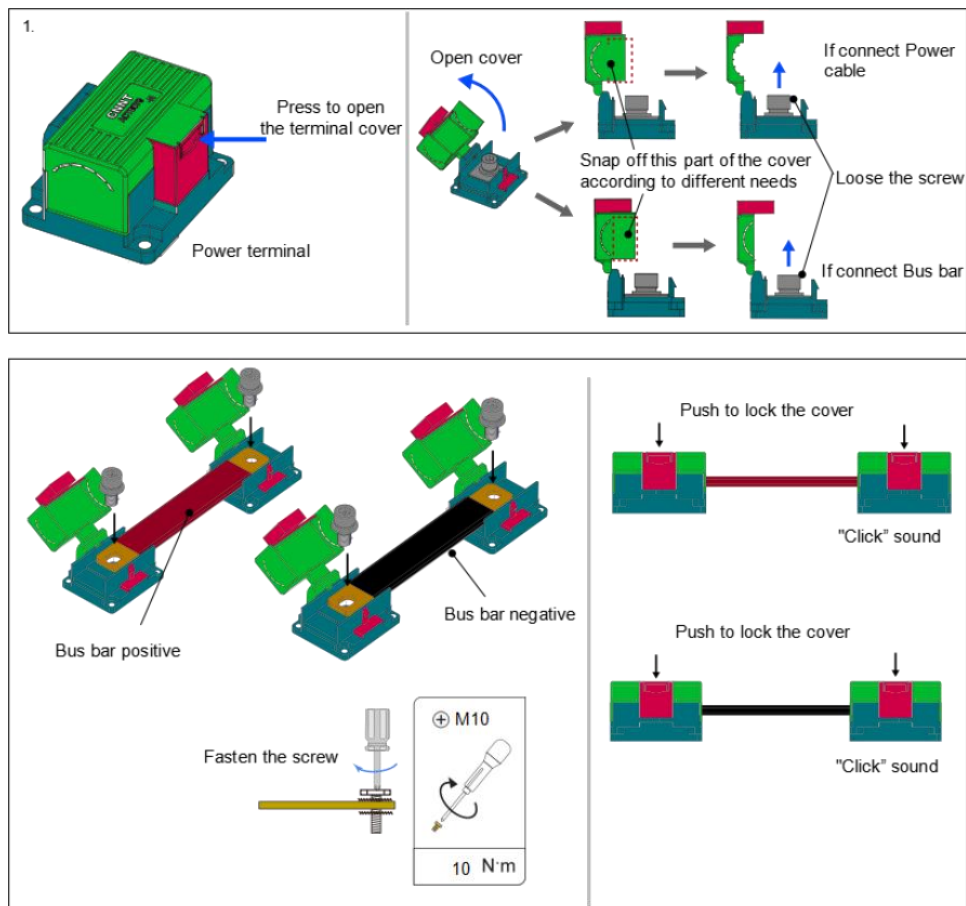

**Step 5: Connecting the Power Cables to the Inverter**

- Connect the positive (+) power cable from the Master battery to the positive (BUS +) terminal of the inverter.
- Connect the negative (-) power cable from the last battery in the chain to the negative (BUS -) terminal of the inverter.
- Connect the communication cable from the EXT-CAN port of the Master battery to the BMS port of the inverter.

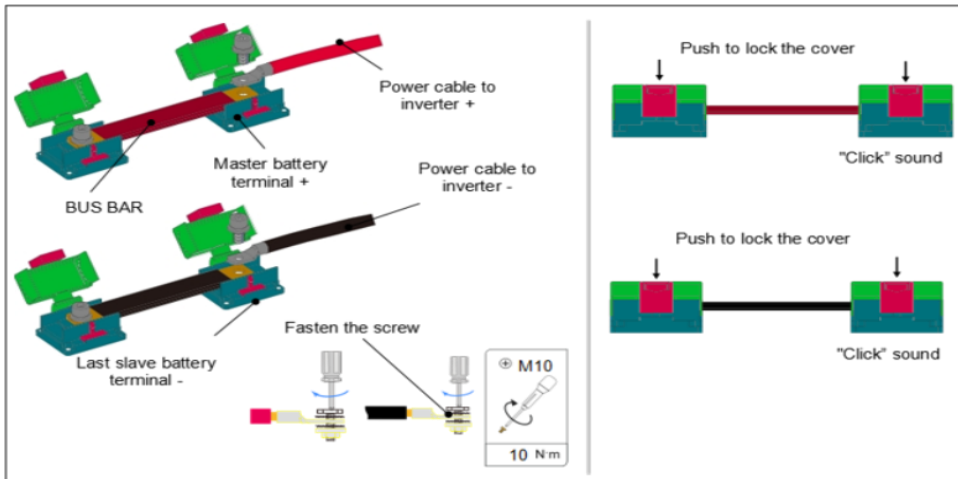

**Step 6 – Final Check Before Powering On**

- Check the earth continuity (PE) with the tester again.
- Check the connection of the inverter and the correct setting of the same
- Check all connections for tightness.
- Make sure there are no foreign objects, metal shavings, or crushed wires.

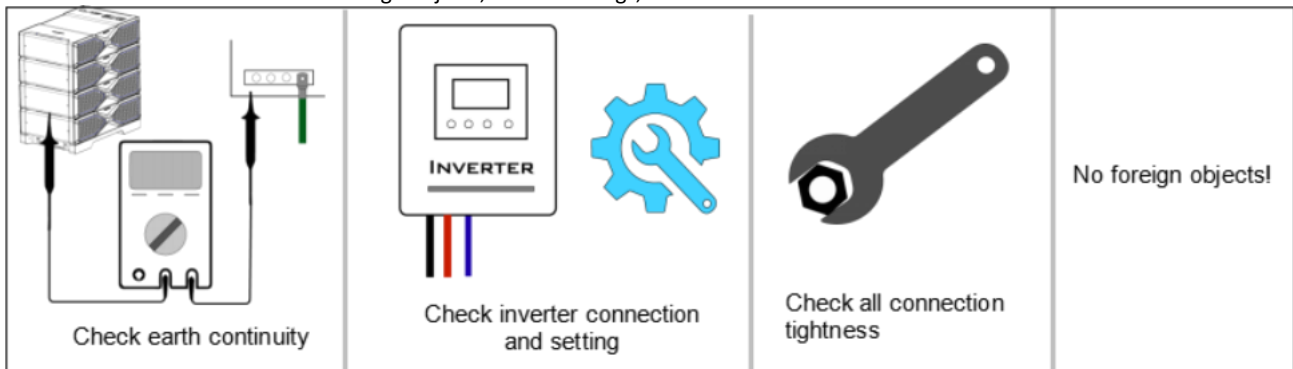

**⚠ Safety Notice**

Only after these checks is it possible to proceed with the system start up procedure



**Attention:** The CAN interface of the BMS is an RJ45 port with the EXT-CAN definition as shown below

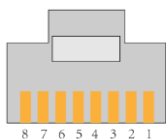

PIN	8	7	6	5	4	3	2	1
Definition							CAN_L	CAN_H

## 4.6 System commissioning and decommissioning

### 4.6.1 Check before activation

	Checking	Acceptance Criteria
1	The inverter used to connect to the battery module is installed in place	The inverter is installed correctly
2	WiFi antenna is in place	WiFi antennas are installed correctly and are robust and reliable.
3	The cables are well arranged	The correct cable arrangement according to current regulations
4	Cable fixing and protection	Cables are securely attached and protected
5	Reliable grounding	The earth connection is correct and complies with the reference values in the country of installation
6	Disconnect the switch	The control module's "Power Switch" and all switches connected to the battery modules are in the "OFF" state.
7	Cable connections in place	DC power cables, DC output cables, communication cables and are connected correctly and securely and reliably.
8	The DC power cables, DC output cables, and communication cables are connected correctly, securely, and reliably.	DC power cables, DC output cables, communication cables are connected correctly, safely and reliably.
9	The installation environment meets the requirements	The installation space is clean, healthy and easy to access, the environment is tidy and there are no residues

#### Before proceeding with the installation, check the following:

- All modules must be turned off.
- All modules must belong to the same production batch; Alternatively, the production date of each module must not differ by more than 6 months.
- The enclosure must not have damage, dents or deformation due to impact or transport.
- The installation site must comply with the requirements of this manual and the regulations in force.
- The battery should be installed at least 20 meters from heat sources, in an area protected from sparks or extreme temperatures.
- The support, slab or structure must be verified from a static and structural point of view.
- The connection cables between the inverter and the battery, and between the batteries, must be as short as possible to minimize voltage drop.
- The battery should be installed away from flammable gases, fuels, or liquids. Internal contactors and electronics can generate sparks during normal operation.
- Do not connect batteries of different capacities, different models, different designs or from other manufacturers in parallel.

### 4.6.2 System Commissioning

After the batteries have been installed and the inverter has been correctly installed and the electrical connection has been correctly completed:

#### STEP 1: System Boot and WiFi Set Up

- **Powering Up the Master Module**
  - Press the **power button on the main (Master) battery module**.
  - **Do not** manually turn on the other modules: they will be started in sequence by the Master, which will initialize the **auto-addressing process** of the Slave modules.
- **Initial Display Verification**
  - Check that the LED bar lights up and shows SOC status within 10 seconds.
- **Wi-Fi connection**
  - Wait for the Wi-Fi icon LED to remain solid.
- **Sequential power-up of slave modules**
  - All battery modules will be automatically switched on sequentially by the Master.
- **Verification of recognition by the inverter**
  - Once the start-up sequence is complete, verify that the inverter recognizes all batteries and the total installed capacity.

- Connect via Wi-Fi or Bluetooth to the Master to verify that all batteries are connected and activated correctly.
- **Connecting to the WECO App**
  - Use your smartphone and open the WECO Bluetooth app.
  - Connect to the Master battery and then repeat the operation for all Slave batteries.
- **Accessing the home page**
  - Within the app, select < battery module> to access the home page.
- **CAN Protocol Verification**
  - Check the battery data and CAN protocol.
  - If the protocol is incorrect, set the appropriate one.
- **Firmware update (if necessary)**
  - Update the battery module via the app if a new firmware version is available.
- **Repeat procedures for each module**
  - Repeat the check and update steps for each battery in your system.
- **Reference to detailed information**
  - For more details on using the app and the available functions, please refer to **Chapter 7** of this manual.

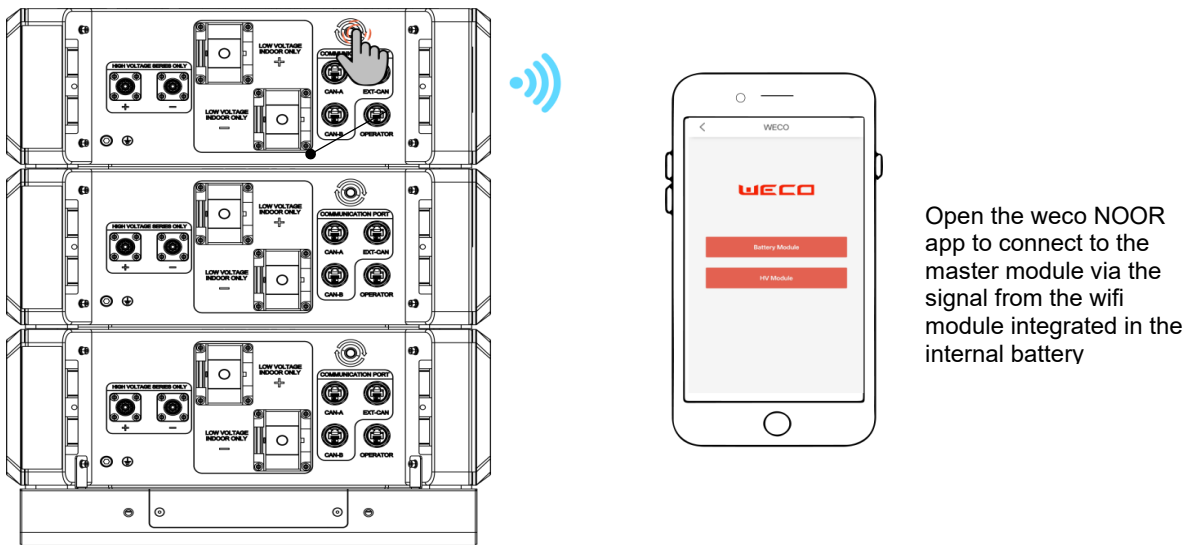

The battery LED bar can indicate the battery SOC status and alarm states by showing a different color scheme. The LED bar consists of LED 1 to LED 5 as shown in the figure below.

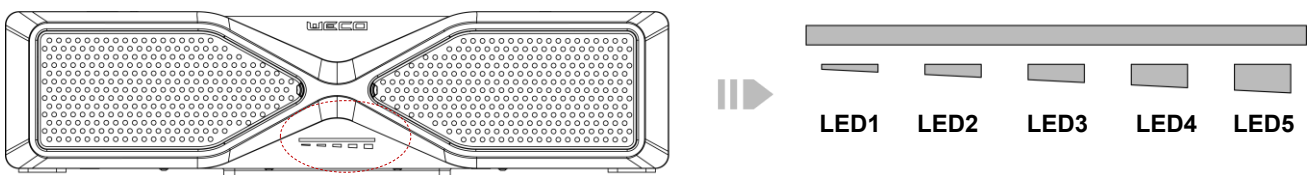

LED STATUS	DESCRIZIONE	SIGNIFICATO
	Led1~Led5 are green, not flashing.	SOC status indication: 98%≤SOC ≤100%
	Led1~Led4 are green, not flashing.	SOC status indication: 80%≤SOC <98%
	Led1 ~ Led3 are green, not flashing.	SOC status indication: 60%≤SOC <80%
	Led1~Led2 are green, not flashing.	SOC status indication: 40%≤SOC <60%

	LEDs1 are green, not flashing.	SOC status indication: 20%≤SOC <40%
	The LEDs1 are yellow, not flashing	SOC status indication: 5%≤SOC <20%
	The LEDs1 are red, not flashing.	SOC status indication: 0%≤SOC <5%
	All LEDs are constantly blue, not flashing.	Starting the system on
	All LEDs flash red every 1 second. (call for service do not restart, disconnect inverter from battery system)	Critical Faults: (System Locked - Requires Intervention to Unlock): Charge/discharge overcurrent Charge/discharge overvoltage Charge/discharge overtemperature
	All LEDs are constantly red. (call for service do not restart, disconnect inverter from battery system)	System faults (contactor disconnect system failure caused by over-temperature/over-current/over-voltage/under-voltage/under-temperature, etc.): Level 3 Charge/discharge overcurrent Level 3 Cell/Total Voltage Charge/Discharge Overvoltage/Undervoltage Level 2 Over-temperature/Low charge/discharge temperature Heating element failure Contactor failure
	All LEDs are constantly yellow.	System Errors (System Failure Due to Communication Issues): External inverter communication error 1. Internal communication error
	Led5 is constantly blue.	During the firmware update

**STEP 2:** After entering the WECO Bluetooth app home page, click  to set the configuration of WIFI networks:  
Make sure the wifi frequency band is 2.4G and enter the SSID and password as follows:

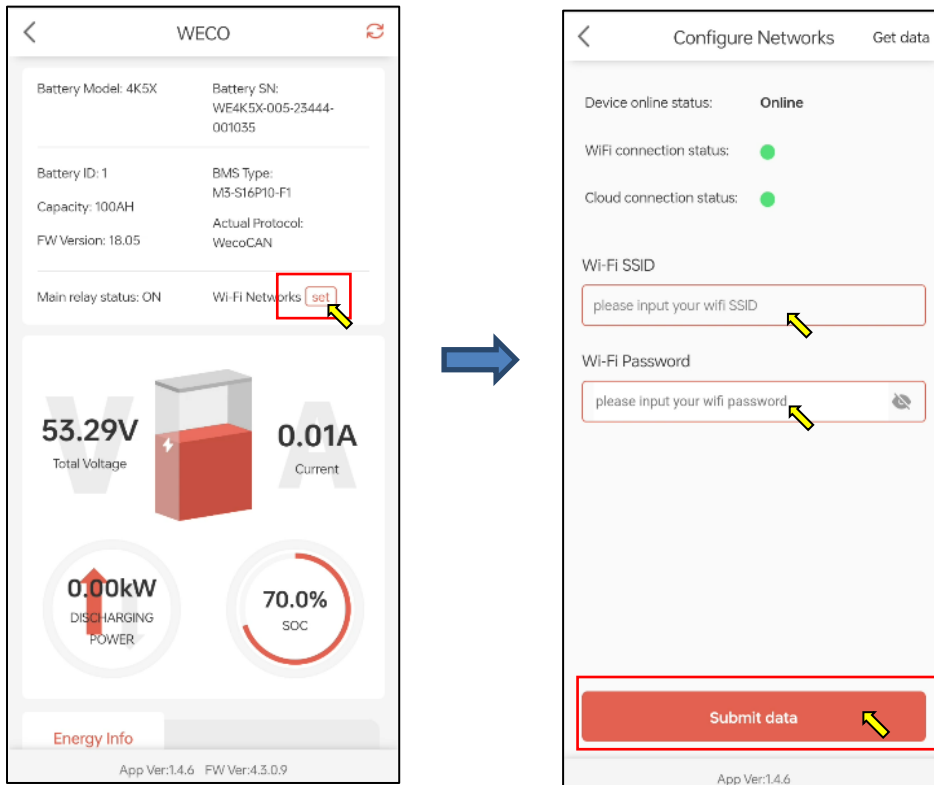

**STEP 3:** Set the protocol according to the inverter brand used for connecting with the 5K3-EVO (Refer to *Appendix C* for reference of compatible inverters and selection of protocol) as follows:

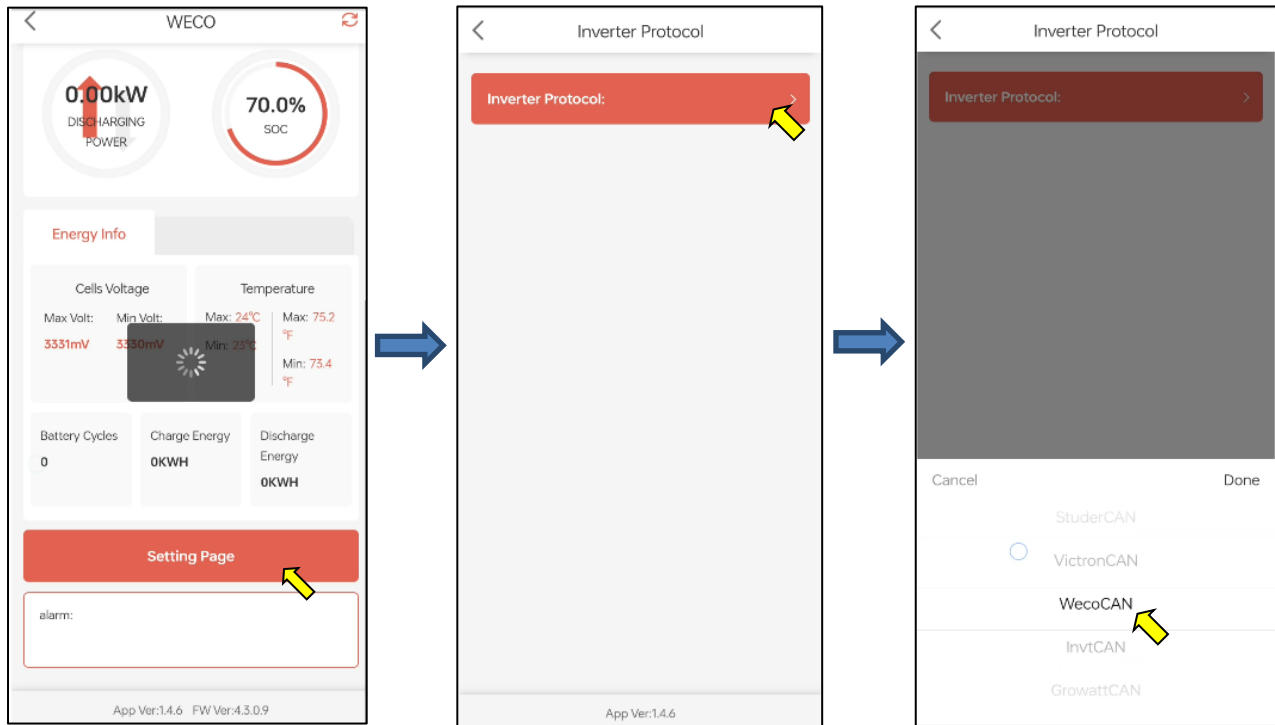

**STEP 4:** After finishing the battery setup, configure the inverter according to the manufacturer's instructions dell'inverter.



Warning

Make sure that the inverter to be connected is compatible with the 5K3-EVO battery module, make sure that the DC voltage of the 5K3-EVO is within the allowed range of the inverter, make sure that the protocol setting of the inverter and the battery is selected correctly, make sure that the FW of the battery is the last, if not, it is imperative to update all batteries to the latest version before proceeding

**Recap Power-On Sequence**

After completing the installation and proper configuration of batteries and inverters, proceed as follows:

**Preparing the Battery**

- Check that the battery is properly connected to the inverter and the grounding system.
- Make sure that the speaker and communication cables are secured and free from damage.
- With a **tester**, check for abnormal voltages between the terminals before activation.

**Powering Up the Main Control Module (Master)**

- Press the ON switch on the Master module.
- Wait for the Slave modules to start in automatic sequence.
- Check that the status LEDs indicate successful initialization.

**Switching on the inverter**

- Turn on the inverter according to the manufacturer's procedures.
- Check the inverter display for recognition of the battery and the installed capacity.
- Connect via APP or PC to confirm that CAN communication is on.

### 4.6.3 System Decommissioning



WARNING

Risk of injury due to the heavy weight of the battery modules.  
At least more than two operators to work and use the lifting machine for moving the stacking tower modules.

Procedure:

STEP 1: Turn off the inverter according to the inverter manufacturer's instructions.

STEP 2: Turn off all battery modules.

STEP 3: Turn off the DC circuit breaker box or circuit breaker (if present) between the inverter and the battery module.

STEP 4: Disconnect the DC cables between the inverter and the batteries, communication cables.

STEP 5: Remove the battery modules from the top of the stackable tower one by one.

STEP 6: If the battery modules need to be stored, please refer to chapter 8 for more details.

STEP 7: If the battery modules are to be disposed of, refer to chapter 10 for more details.

#### Recap Shutdown sequence

⚠ **Caution** Do not change the shutdown order: An incorrect sequence can cause damage to components or damage the BMS.

##### Switching off the inverter

- Stop the production and/or operation of the inverter according to the manufacturer's procedure.
- Wait for the LEDs and display to come to a complete stop.

##### Turning off the battery

- If provided, set the battery to OFF mode via app

##### Switching off the main control module (Master)

- Press the Master's OFF switch.
- Wait for all Slave modules to be completely disconnected.

#### Additional Notes

- After switching off, wait **at least 15 minutes** before servicing or disconnecting cables.
- Before working on the cables, measure the voltage with a tester and make sure that there are 0Vdc, otherwise do not intervene and contact the manufacturer's after-sales service immediately
- In the event of an emergency, use the **emergency stop button** (if present and if provided for by the technical design) to immediately cut off the power supply.
- Any anomalies detected during switching on or off must be reported and resolved before using the system again, contact customer service immediately after securing the system and turning off the inverter to avoid charging or discharging the batteries in abnormal conditions

## SECTION 3 – HIGH VOLTAGE CONFIGURATION

### 5. High Voltage (HV) Configuration

#### 5.1 HV Configuration

##### Introduction to HV Configuration

The **high voltage (HV)** configuration requires the use of the **5K3-EVO HV BOX module**. The HV BOX is an indispensable protection and communication device and must be installed in any high-voltage configuration, without exception.

In an HV configuration:

A minimum of 2 up to a maximum of 17 battery modules can be connected in series to form a single cluster (always check the voltage range of the inverter).

Up to 10 clusters can be connected in parallel.

The operating voltage range is 80 VDC to 1000 VDC.

For multi-cluster systems, a HV Hub module must be used, which allows for coordinated connection and management between clusters.

The HV configuration supports 1. vertical ground installation, 2. Stacked installation – single tower, 3. Stacked installation, multiple towers. Wall installation is not permitted.



##### Summary Table

Configuration	HV	Required Accessories	Note
Wall mounting	NO	Not Possible	Wall mounting installation is not possible in HV
Vertical ground installation	Yes	HV BOX: H00089 - Mandatory	Rubber pad included in the battery kit
Stacked on the base, single tower	Si	HV BOX: H00089 - Mandatory	The base for the single tower it's included in the HV BOX kit
Stacked on the base, multiple tower	Si	HV BOX: H00089 - Mandatory HV Base: C00637	HV Base Kit C00637 required for the additional tower

#### 5.2 Pre-Installation check

The battery module is packed in boxes with accessories.

Upon receipt, carefully check the delivery slip and the contents of the boxes.

Make sure the battery module and accessories are as ordered and visually inspect to ensure they are not damaged.

If the battery is damaged and/or components are missing, contact your local WECO representative, store the battery in its box in a sheltered, safe place away from flammables, affix a hazard sign and preach the necessary safety operations in accordance with the safety plans prepared by the person in charge and/or the construction manager.



**ATTENTION!**

Use of this product in a manner not in accordance with the **instructions** in this manual will void the **warranty**. Any **replacement, modification, or alteration** of components of this battery module not authorized by the manufacturer will void the warranty.  
The use of components internal to or connected to this battery module **that are not supplied as part of the product or not expressly recommended by the manufacturer** will void the warranty

### Packaging list

For the number and type of items supplied with the product, please refer to the **Packing List** included inside the package. The list below is provided **for reference only**. Actual delivery is based solely on the **Packing List** in the package. If you have any concerns or discrepancies regarding your supply, please contact your dealer.



### ATTENTION!

LV KIT cables cannot be used for connection in high voltage configuration, as LV cables are not designed for high voltage. HV Box is mandatory for HV configuration.

## 5.2.1 List of Accessories Included with Battery

### 5.2.1.1 HV Battery Standard Accessory Pack (codice batteria HV – B00110)

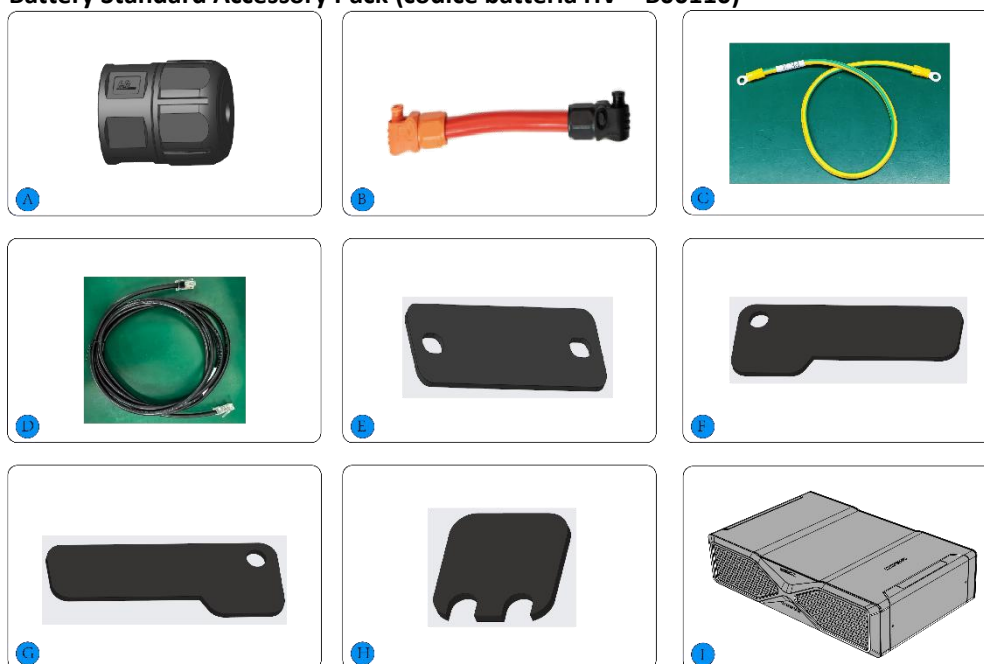

Item	Nome	Function &Description	QTY
A	RJ45 Waterproof Plug	Waterproof short plug at the end of the RJ45 cable, (IP67 after tightening)	2
B	High-voltage series cable	Power cable with plug Red/Black HV 190 mm/4 AWG.	1
C	Ground cable	230 mm/8 AWG yellow-green wire with OT (HRV8-6) terminals crimped on both ends	1
D	Battery CAN communication cable	8-core communication network cable, 200 mm black	1
E	Fixing bracket	64*20*1.5mm	4
F	Anti-vibration bearing A	140*50*4mm	1
G	Anti-vibration bearing B	140*50*4mm	1
H	Anti-vibration bearing C	50*50*4mm	2
I	Battery	Battery	1

### 5.2.1.2 HV BOX Standard Accessories Package (H00089)



Item	Name	Function &Description	QTY
A	HV Positive Output Cable	One end of the cable is equipped with an <b>energy storage connector plug</b> , while the other end is terminated with <b>OT lug (SC25-8)</b> . The cable is <b>red</b> , with a <b>length of 2.5 meters</b> and a <b>section of 4 AWG</b> .	1
B	HV Positive Output Cable	One end of the cable is equipped with an <b>energy storage connector plug</b> , while the other end is terminated with <b>OT lug (SC25-8)</b> . The cable is <b>black</b> in color, with a <b>length of 2.5 meters</b> and a <b>section of 4 AWG</b> .	1
C	Inverter Communication Cable	PIN1/2 to PIN4/5, 2.5meter black	1
D	RJ45 Waterproof Plug	IP67 RJ45 waterproof plug after tightening	3
E	Positive cable from HV box to battery	Both ends have orange HV quick connectors, 190 mm/4 AWG red wire	1
F	Cable from HV box to negative battery	Both ends have black HV quick connectors, black 1.5 meter/4 AWG wire	1
G	HV Box Grounding Cable	2.5meter/8AWG yellow-green cable with OT terminals (HRV8-6) crimped at both ends	1
H	Base	Base	1
I	Base fixing bracket 1	Attached to the base using countersunk screws, used to secure the stacked batteries, this item is installed on-site by the customer as an accessory (used with the base)	2
J	Base Fixing Bracket 2	Base Fixing Bracket 2, fixed on the base with a pressure grub screw, used for fixing the stacked battery, this item is installed on site as an accessory (used with the base)	2
K	Hex Self Tapping Expansion Screw M6*60	The entire base is secured and used, and this item is installed on-site as an accessory (used with the base)	4
L	Hex countersunk screws M4*8	Fixing bracket and baffle for fixing the base ((used with the base fixing bracket 1, the base fixing bracket 2 and the baffle)	6
M	HV BOX body	HV BOX body	1

### 5.2.1.3 5HV Optional Accessory Kit (for use with two towers – C00637)



Item	Name	Function & Description	QTY
A	Battery communication cable	Red 1.5 m (4 AWG) cable with an orange plug energy storage connector on one end and a black plug energy storage connector on the other.	1
B	Extension cable for battery communication	1.5 m (8 AWG) yellow-green cable with OT (HRV8-6) cable lugs crimped on both ends.	1
C	Extension cable for battery communication	8-Wire Communication Network Cable, 1.5 m Black	1
D	Base	Base	1
E	Base Fixing Bracket 2	Base Fixing Bracket 1, attached to the base by countersunk screws, used to secure stacked batteries, this item is installed on site by the customer as an accessory (used with the base)	2
F	Base fixing bracket 2	Base Fixing Bracket 2, fixed on the base with a pressure grub screw, used for fixing the stacked battery, this item is installed on site as an accessory (used with the base)	2
G	Hex Self Tapping Expansion Screw M6*60	The entire base is secured and used, and this item is installed on-site as an accessory (used with the base)	4
H	Hex countersunk screws M4*8	Base Fixing Bracket (used with Base Fixing Bracket 1, Base Fixing Bracket 2 and Baffle)	6
I	Pass-through box	Used in the center of two base groups for protection in cables between clusters	1
J	Pass-through box cover	On-site installation and customer use (Used with feed-through box)	1
K	M4*6 Flat Hexagon Carriage Head with Plug Screws	Screws for fixing the pass-through box	8

## 5.3 General Preparation

### 5.3.1 Installation Location

The battery module, HV box, and accessories must be installed in a suitable location and in accordance with the instructions in the manual. The degree of protection of the battery should not be interpreted as an implied authorization to install it outside without any protection. The battery must be placed in an area protected from the sun, water and frost, protected from atmospheric agents and possible contamination or aggression of a liquid, solid or gaseous type.

The installation process must take into account future maintenance needs. Operation must comply with local regulations, as well as international, national, and regional standards applicable to lithium-ion batteries.

During installation and use, avoid direct exposure to sunlight, rain, and snow accumulation. It is recommended to choose a protected site and install the module under a cover or canopy.

#### ATTENTION

The roof must cover the battery from the sun and precipitation

As a general rule, in order to protect the product from water or radiation, it is necessary to adopt an adequate coverage ratio between the height of the roof (h) and the distance from the product from its projection to the ground.

The communication must ensure protection against splashes and condensation

Refer to the figure below for the recommended location.

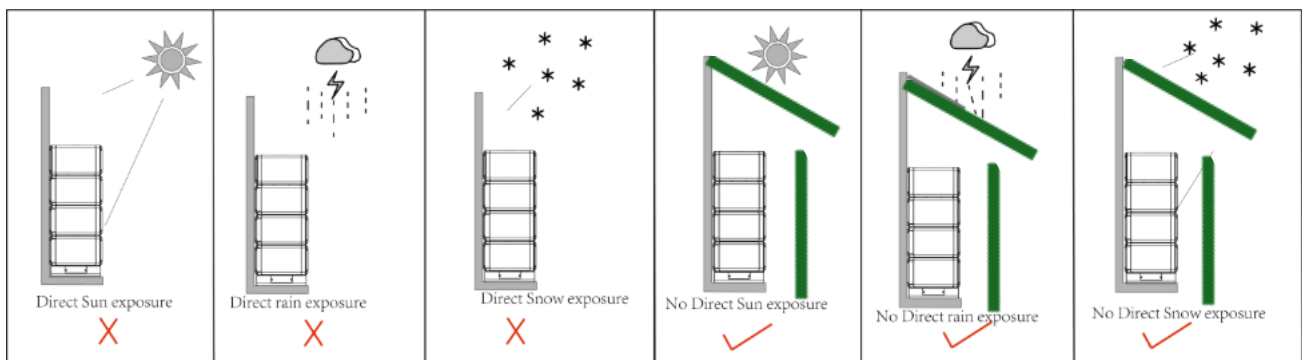

The distance between the system and surrounding objects must comply with the following conditions:

Side distance (left and right)  $\geq 500$  mm

Distance  $\geq 300$  mm

Front distance  $\geq 500$  mm

These clearances must be ensured to allow for proper installation and proper heat dissipation space.



**Warning!**

#### Battery Installation Warnings

Make sure **all modules are turned off** before beginning installation.

The work area must be **clean** and away from any water sources (taps, drains, sprinklers, etc.) to prevent infiltration.

Check that the battery casing is **free of damage**, dents, or deformation caused by impact.

The installation site must be **away from heat sources**, protected from any source of fire, open flames or other sources of extreme temperatures.

The **connection cables** between the batteries and the inverter should be **as short as possible** to avoid excessive voltage drops.

Installation should be made **away from flammable gases, combustibles, or liquids/gases**. Internal electronic devices may generate **sparks during** normal operation.

Before connecting the battery, carefully check the **polarity** of the positive and negative poles to ensure proper installation.

The installation location must be **appropriate for the weight and size** of the battery system, with a suitable load-bearing structure

## Safety Statement for LV and HV Systems

The battery system should always be installed in a shaded area, fully protected from precipitation, splashing water and dust ingress.

The LV kit is supplied on request with busbars and special rubber protections that improve water and dust resistance.

However, despite the IP protection of the system, the battery is not suitable for direct outdoor installations without protection

The product must be placed under a properly designed cover or roof that protects it from sunlight, rain and snow, the battery must remain dry and condensation-free.

The protective roof must cover the entire footprint of the product and must have an additional coverage area all around it to prevent water, rain, snow, and sun from having a direct impact on it.

As a general guideline, the height of the cover (h) should not exceed 2.5-2.8 m, and the overhang (d) on each side should be at least equal to h by 2, ensuring that water and solar radiation cannot directly affect the equipment.

The project must prevent the flow of water at the installation site under all conditions, including flooding scenarios.

The battery must be installed on a pedestal higher than in a possible water flooding event

**For BT clusters**, the modules must be carefully stacked with the fixing brackets properly tightened, then attached to the wall. The capacity of the floor must be checked by a technician before the operation and, if necessary, additional reinforcement must be applied. The rubber guards on the busbars must be installed correctly.

**For HV clusters**, the system must be installed in a dedicated room or enclosure with controlled environmental conditions and the HIGH VOLTAGE marking must be added to name the user of the hazard.

Busbar connections, contactors and HV switches must remain protected from moisture and contamination.



### IMPORTANT NOTICE DANGER



As a general rule, batteries should be installed in a segregated and controlled area, where access is strictly restricted to authorized personnel only. This measure prevents accidental interference and ensures that safety procedures are adhered to at all times.

In addition to access control, the installation site must be designed with environmental protection measures to avoid contamination by dust, moisture or chemicals, as already explained in relation to shading, covering and water protection. Proper segregation and environmental protection are essential to preserve both the safety and longevity of the product.

The Director Engineer or the responsible authority has a duty to review, approve and, if necessary, request additional protective measures to ensure that the installation complies with best practices, safety standards and long-term reliability requirements.

### 5.3.2 Installation Tools

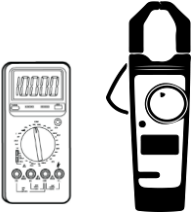
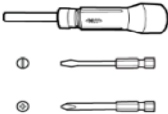
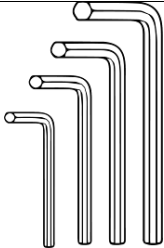
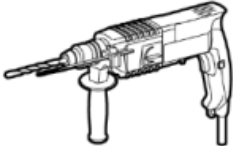
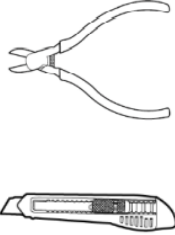
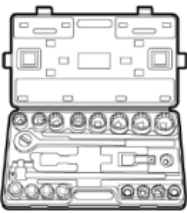
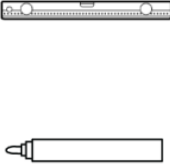
Based on the different installation methods, installing this battery system will require the use of all or part of the following tools:

 <p>Multimeter + Clamp Meter</p>	 <p>Insulated screwdriver set</p>	 <p>Set of insulated Allen keys from 2 mm to 8 mm</p>	 <p>Drill + Hammer</p>
 <p>Scissors &amp; Cutters for Electricians</p>	 <p>Insulated torque wrench set</p>	 <p>Horizontal ruler + markers</p>	 <p>Equipment for security personnel</p>

## Tightening torque requirements

When using screw tightening (bolt), all connecting fasteners must meet the torque or clamping force and must not experience plastic deformation, cracks or breakage.

### Screw tightening torque table

Screw type	M3	M4	M5	M6	M8	M10	M12	M16
(N*m)	0.7-1	1.8-2.4	4-4.8	7-8	17-20	34-40	60-70	119-140

## 5.4 Install the Battery Module and HV BOX Module



### ATTENTION!

#### Safety Warning – Battery Module Handling

- The weight of the battery module poses a risk of injury if it is not lifted and handled properly. The danger may occur in the event of incorrect lifting or accidental fall during transport or installation.
- To ensure operator safety and product integrity:

#### Safe handling

- Lift and position the battery module carefully, using proper lifting techniques and, if necessary, the help of multiple operators or suitable equipment.

#### Personal Protective Equipment (PPE)

- Always wear appropriate PPE (protective gloves, safety footwear, lumbar protection) during all handling, transport and installation operations.

#### Authorized personnel

- Installation and handling must be carried out only by qualified personnel



### ATTENTION

The battery has two square-shaped handles that are covered by the side covers, which need to be moved by two people. Before starting any operation on the battery, be sure to place the modules in their final position and structurally secure all modules that make up the system to a previously verified surface and/or the previous battery



### ATTENTION

The use of the HV BOX is mandatory, HV BOX has a minimum starting voltage of 80 Vdc, (Two 5K3-EVO modules in serial connection) however it is recommended to use a minimum of four modules to have an adequate energy buffer to avoid the low voltage shutdown of the HV BOX during a long standby period of the inverter, or due to the inactivity of the solar charger.  
Always check the minimum starting voltage of your inverter as it may require multiple battery modules in series



### ATTENTION

The maximum number of battery modules that can be connected in series is 17. Ensure that the supporting floor has been properly inspected by a qualified technician before beginning installation. For reference, a group of 16 batteries in series, including the HV box, weighs approximately 906 kg (one battery weighs 55 kg).



### ATTENTION

A tower must have no more than 8 battery modules. For example, a cluster with 17 battery modules can include a tower of 8 battery modules and a tower of 8 battery modules plus the HV BOX module, or include more than 2 towers.

## Procedure

**Step 1: Batteries should be stacked, rear brackets should be removed if installed.**

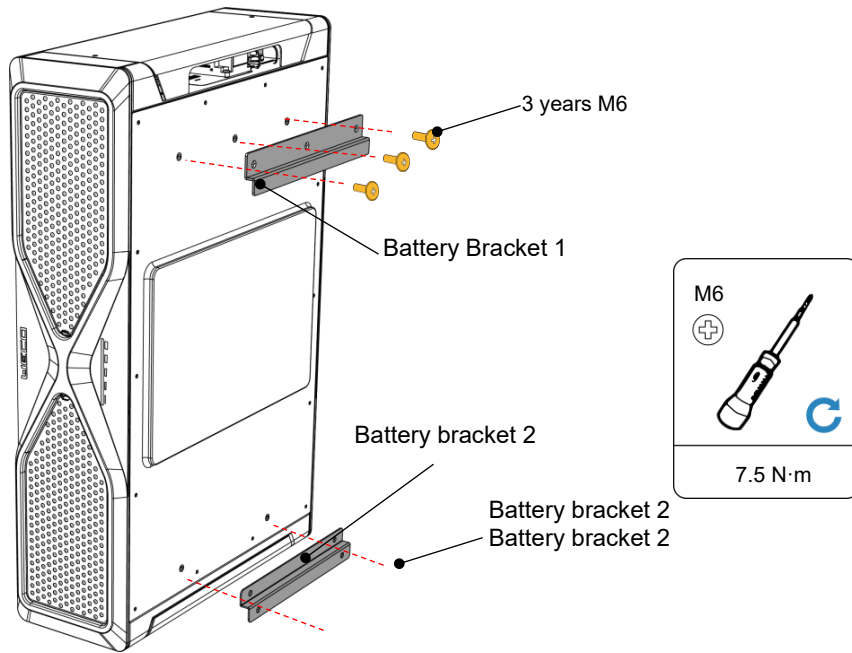

## Step 2: Install the base.

1. Place the base on a solid floor.
2. Use a level to make sure the base of the floor is level.
3. Mark the base mounting holes with a marker and drill holes with a hammer drill.

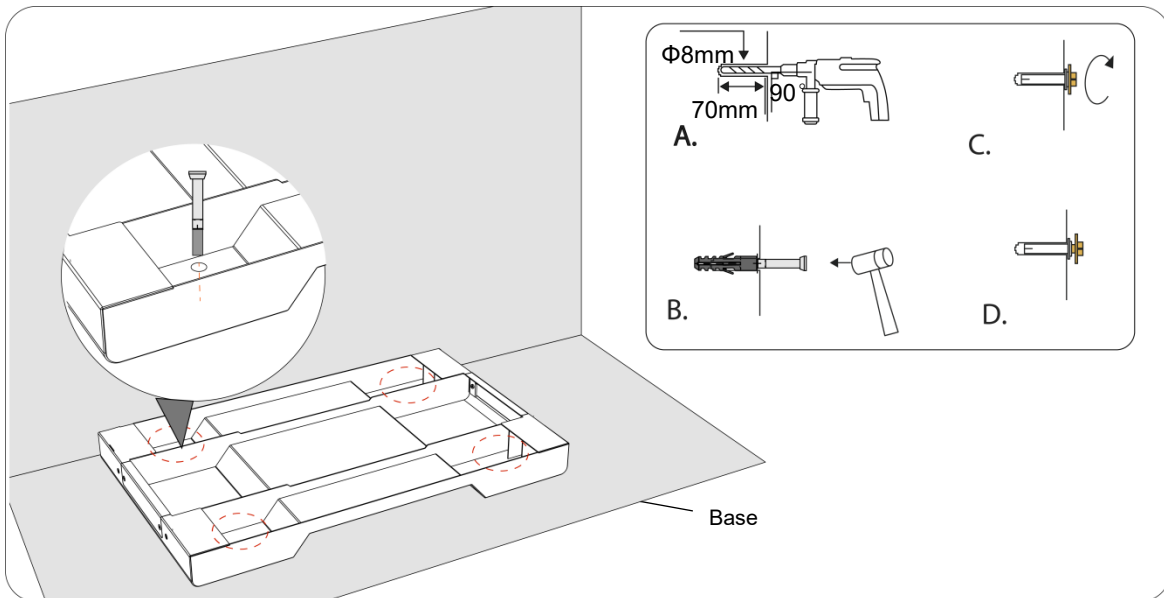

### Step 3: Remove the protective covers as follows.

1. Remove the top cover.
2. Remove the top side cover.
3. Remove the bottom cover/BMS.

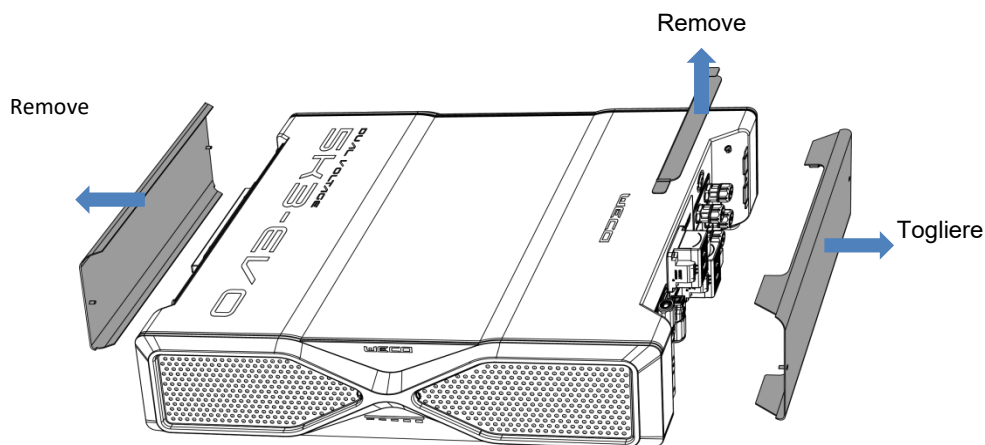

Remove

- Remove the bearings from the accessory kit supplied with the battery. There are two types of bearings used for stacking to prevent shock and vibration. Attach the pads to the four corners of the back side of the battery.

### Step 4: Stack the Battery Modules.

1. Stack the first battery module on the base.

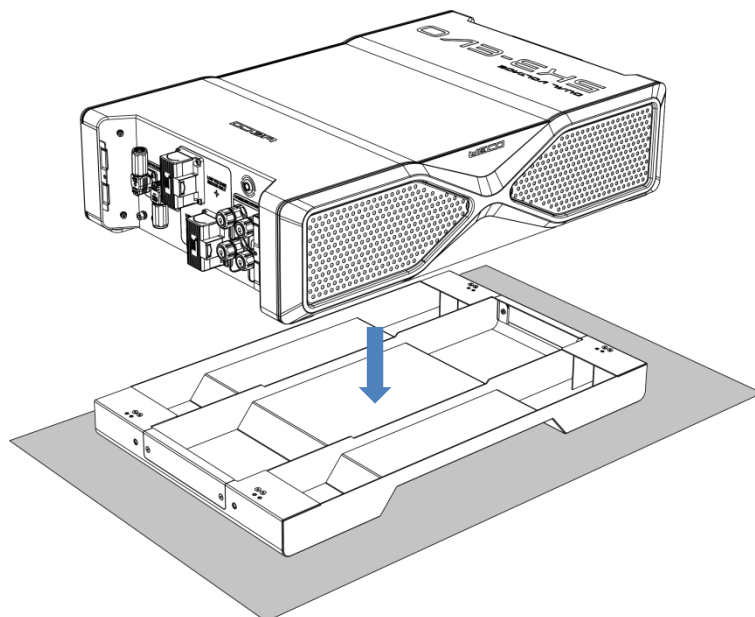

Interlock the stacked pieces between the first battery module and the base.  
Tighten the base and the first battery

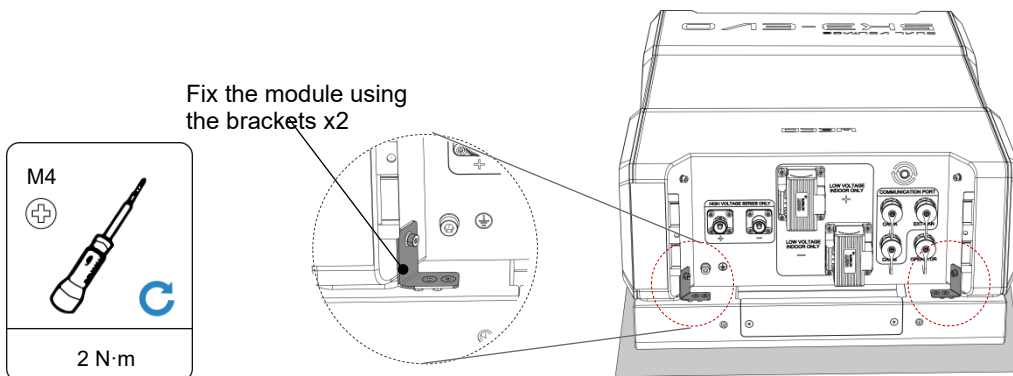

Fix the module using the brackets x2

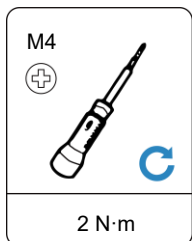

Tighten the base and the first battery

Front cable access and communication

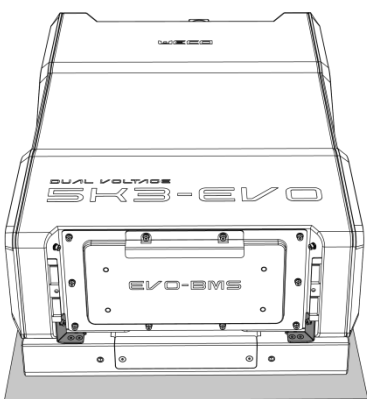

Back view

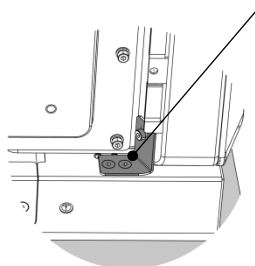

Tighten the screws on the brackets between the base and the first battery.

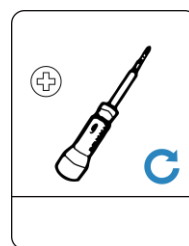

Stack the second battery module on the first battery module and tighten the 4 stacked pieces between the first and second battery modules as follows.

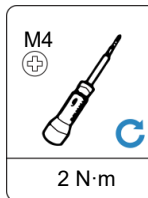
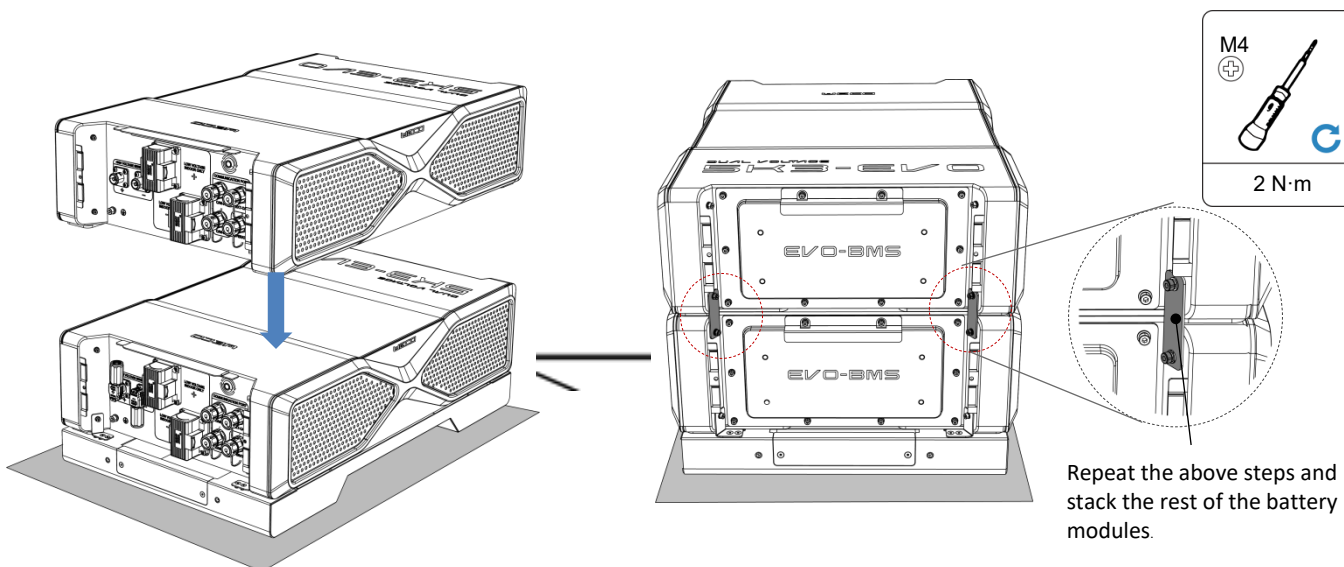

Repeat the above steps and stack the rest of the battery modules.

Repeat the previous steps and stack the rest of the battery modules up to a maximum of 9 for each base (tower) and a maximum of 17 per cluster (always making sure of the maximum allowable voltage of your inverter)

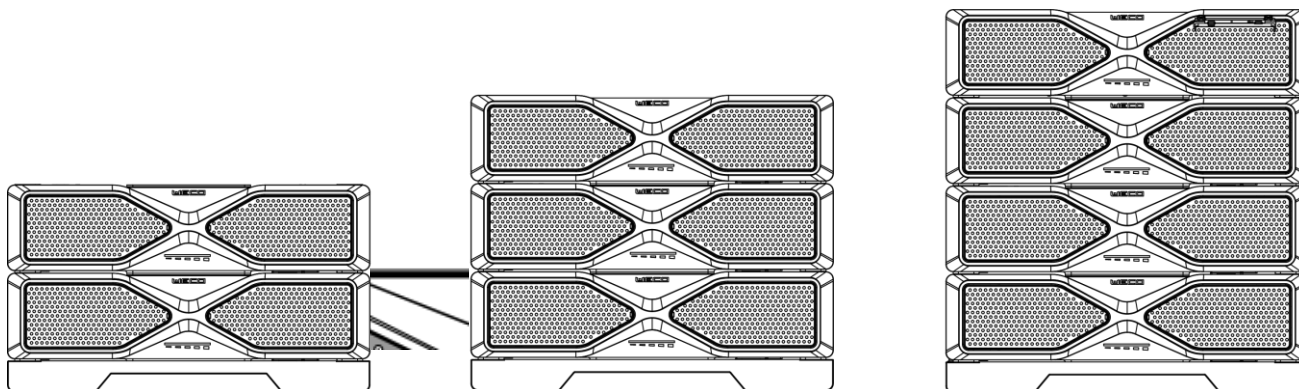

Repeat the above steps and stack the rest of the battery modules up to a maximum of 9 for each base (tower) and a maximum of 17 per cluster (always make sure of the maximum allowable voltage of your inverter).

For a group of 17 batteries.

**DO NOT STACK MORE THAN 9 BATTERIES PER TOWER**

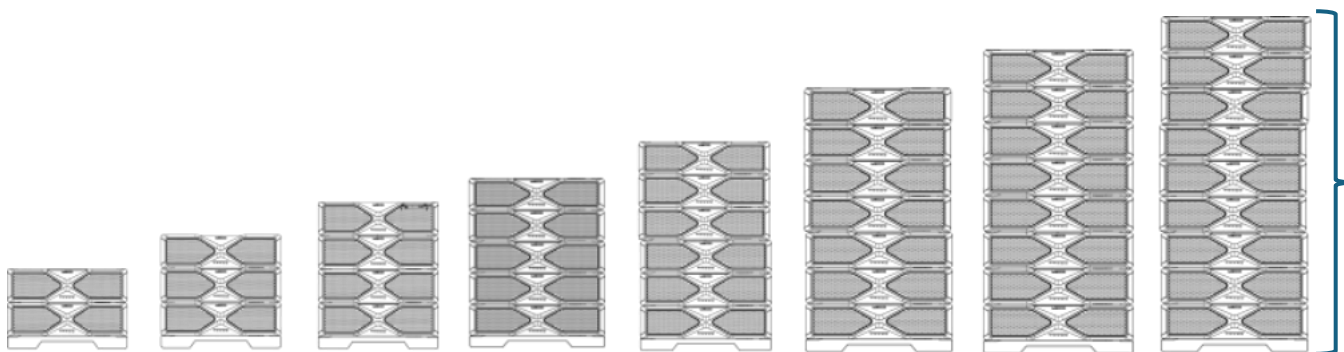

**Step 5: Stack the HV BOX module.**

Detach the top cover and the back and front cover, including the top cover of the HV BOX.

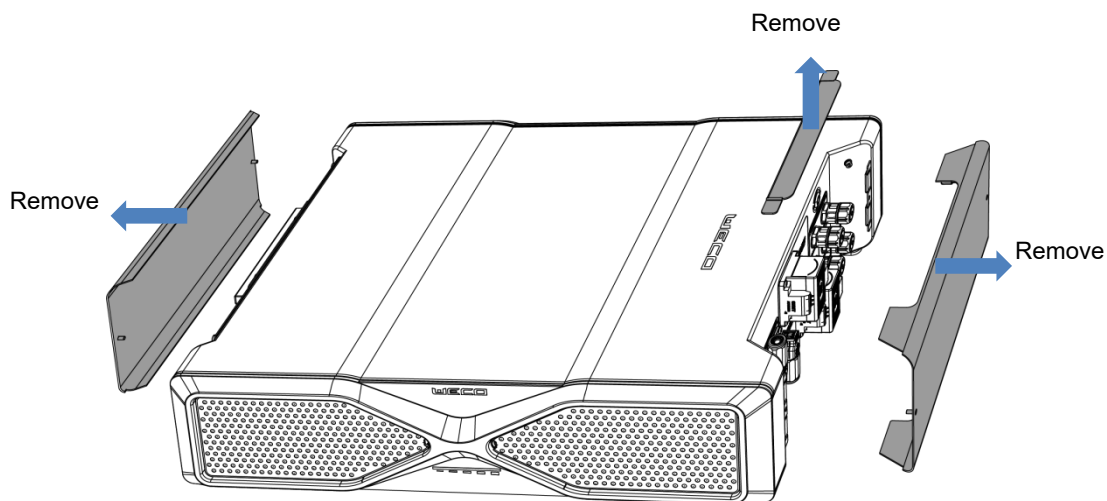

Attach the rubber pads to the rear side of the HV BOX module.

Place the HV BOX module on the top battery of the tower and then secure the piece of stack between the HV box and the battery.

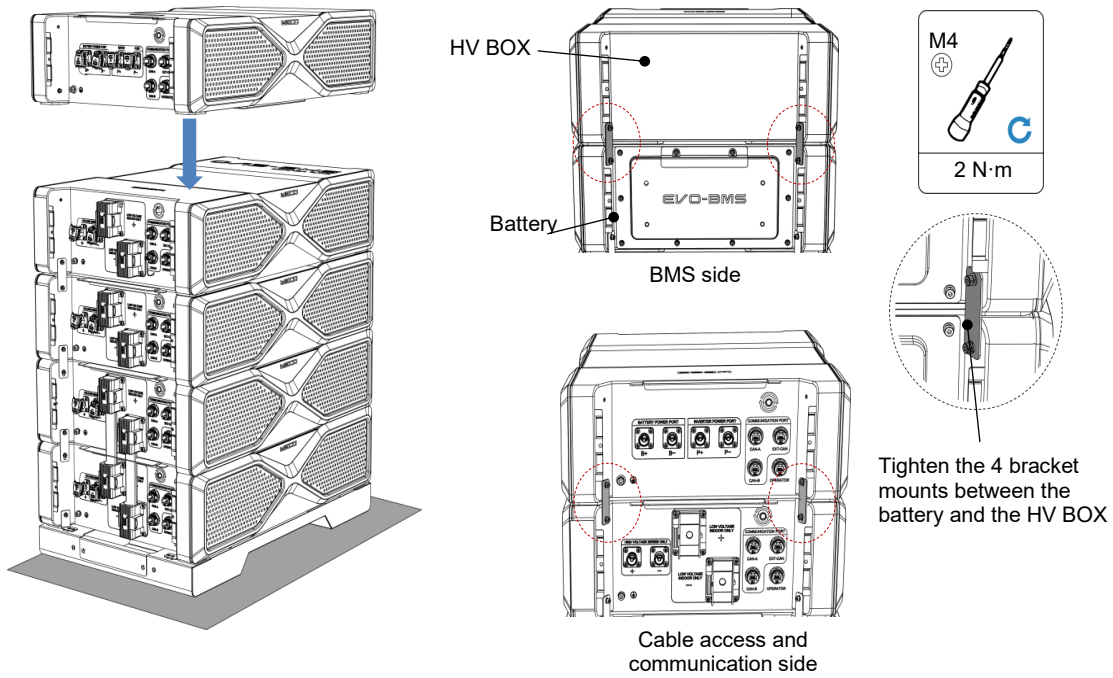

### Step 7: Attach the HV BOX module to the appropriate wall.

1. Install the two L-shaped bracket plates on the side of the HV box module that is located near the wall.
2. Position and adjust the position of two wall brackets according to the distance between the HV box and the wall.
3. Use a marker to mark the location of the holes. Drill holes with a  $\Phi 8$  mm drill.
4. Attach the brackets to the wall by tightening the expansion screws
5. Attach the brackets to the L-shaped bracket plates of the HV box by tightening the screws

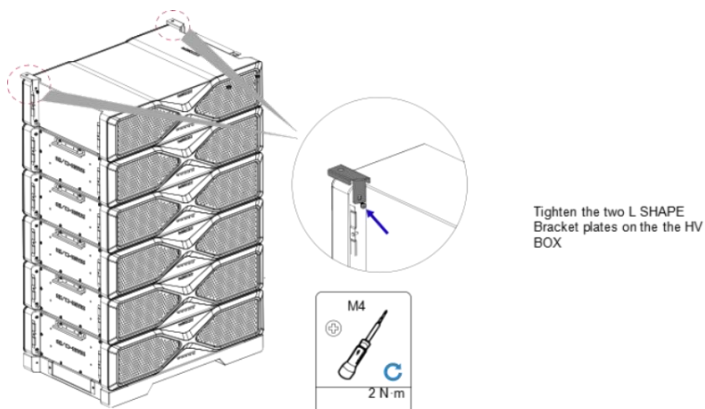

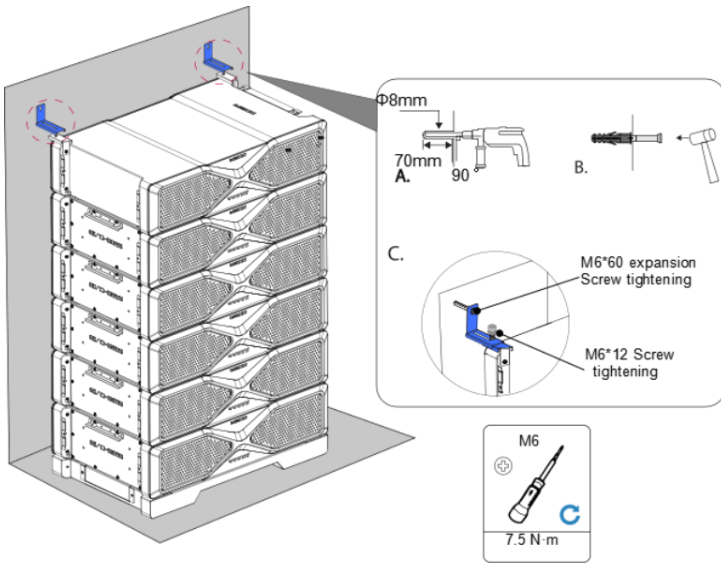



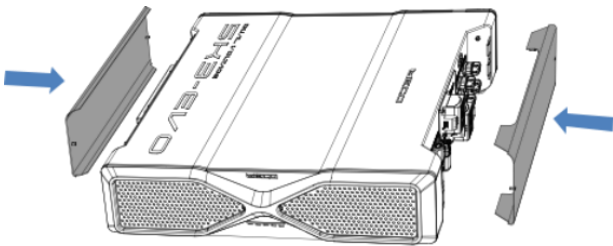





**Step 8: Reinstall all side covers.**



## 5.5 Electrical Connections

 <b>DANGER</b>	<p>The voltage at the conductive terminals of the battery is dangerous. When installing the battery module, it is strictly forbidden to touch the positive and negative terminals of the stacking connector with your hands. Before performing any electrical operation, make sure that all cables are free of damage, cracking, or corrosion.</p>
 <b>WARNING</b>	<p>Do not ground the positive or negative terminal of the battery output, as this may cause serious damage to the battery. Static electricity can damage the battery's electronic components: appropriate anti-static measures must be taken during installation and maintenance.</p>
 <b>ATTENTION</b>	<p>Do not use terminals from other brands or types other than those in the accessory package.</p>
 <b>ATTENTION</b>	<p>Moisture and dust can damage the battery, please make sure the cable connectors are tightened securely during installation. If the battery is damaged due to the use of improperly connected cable connectors, the warranty claim is void.</p>
 <b>ATTENTION</b>	<p>The high-voltage configuration requires all battery modules to be connected in series.</p>
 <b>ATTENTION</b>	<p>Before connecting an HV inverter to the HV BOX terminal, always check the Minimum and maximum voltage value of the inverter and make sure that the voltage range matches the input range of the inverter.</p>
 <b>ATTENTION</b>	<p>A cascade cluster is only efficient if all battery modules are fully loaded. Carry out the LOW VOLTAGE charge from the LV poles with an Inverter equipped with CAN Comm, up to SOC 100%, this process will allow correct equalization between modules in the same cluster.</p>
 <b>ATTENTION</b>	<p>The preparation of HV strings is an important step in the commissioning of an HV system, the installation of an HV system must include equalization of the tower before delivery to the end user.</p>

### 5.5.1 Electrical Connection Diagram

DC breaker to be added in accordance with the local regulations, in case a DC breaker is added **do not turn the battery ON** if the breakers are open as **this will damage and make useless the pre-charge function** to the inverter

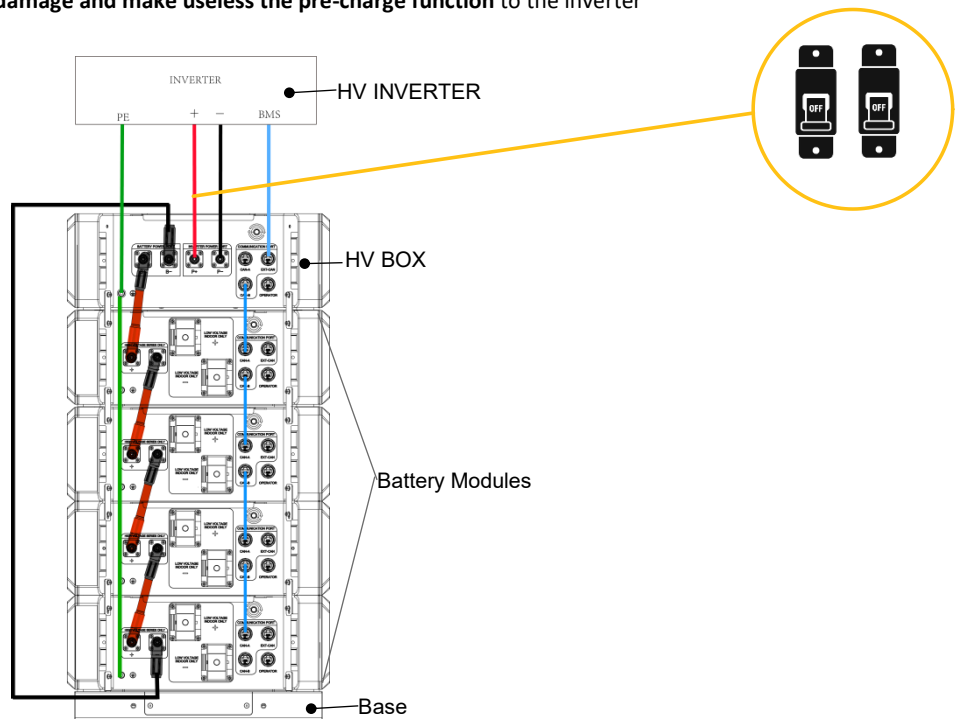

## 5.5.2 Connection Procedure

1. Ground all modules and the base and check the size of the ground pole before and after connecting all terminals as shown in the diagram

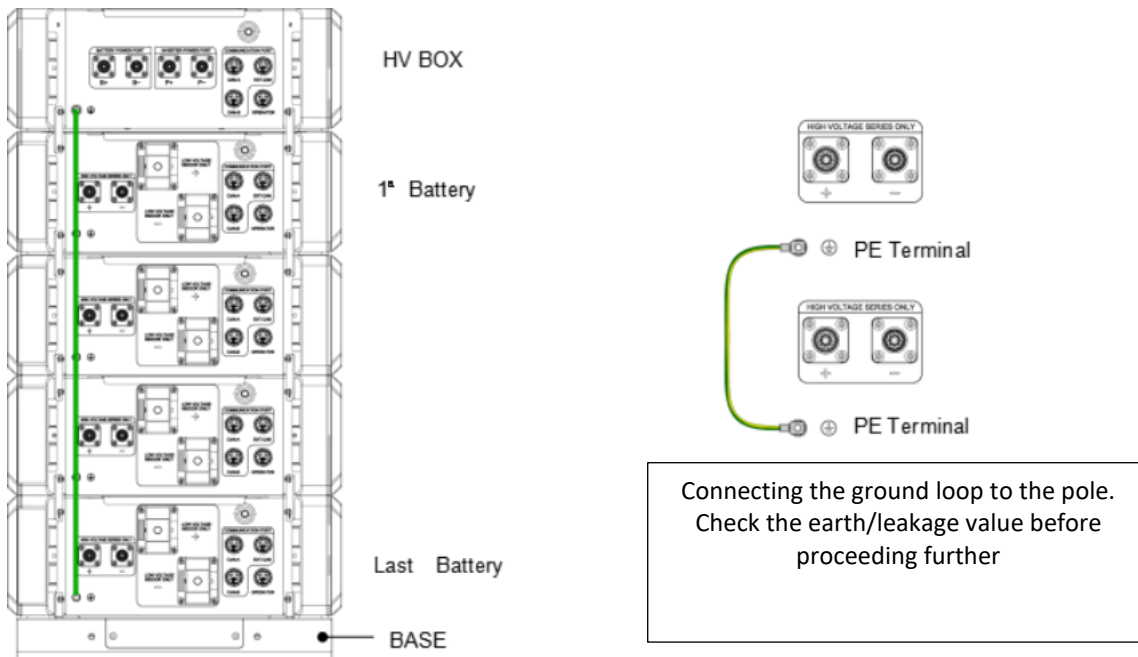

2. Connect the CAN communication cables following the B/A sequence

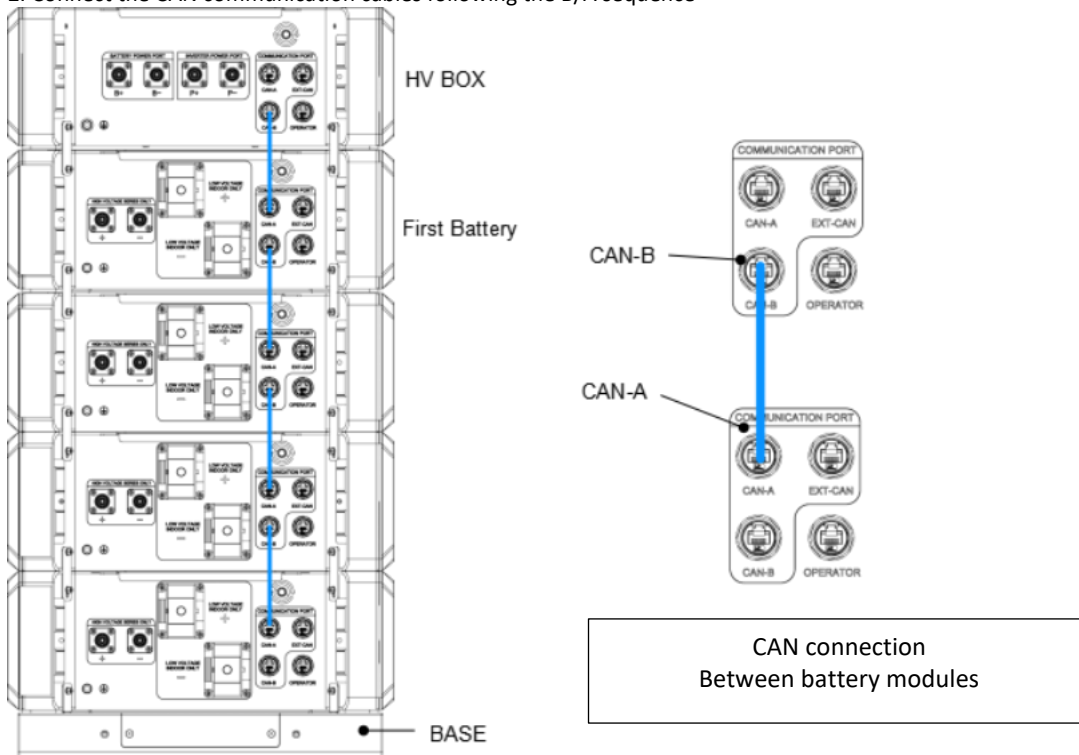

3. Connect the power cables between the batteries.

Connect the battery modules in series, then connect the HV positive terminal of the 1st battery module to the positive battery terminal of the HV BOX and then connect the HV negative terminal of the last battery module to the negative battery terminal of the HV BOX.

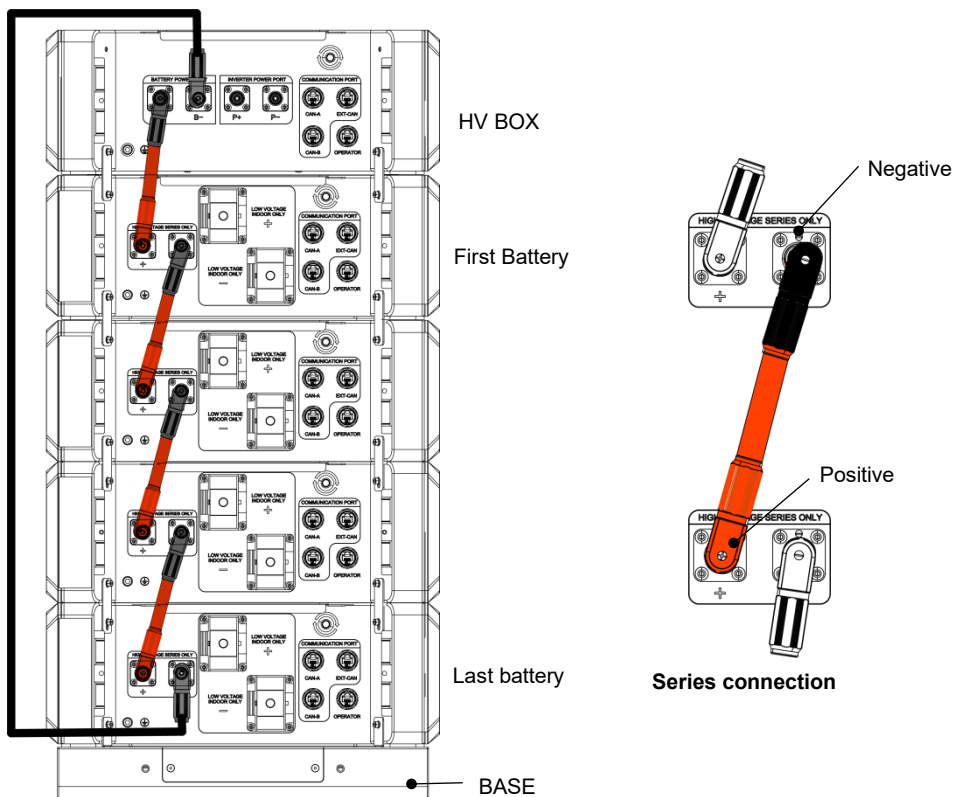

4 Connect the cables between the HV BOX and the HV type inverter.

**Caution:** The CAN interface of the BMS is an RJ45 port with the definition EXT-CAN as shown below. Make sure that the CAN L and CAN H connection to the inverter is correct and that the CAN signal is correctly picked up by the inverter. An incorrect connection could compromise the proper functioning and safety of the system.

CAN communication from HV BOX to INVERTER



5. Connect the cables between the HV BOX and the HV type inverter.

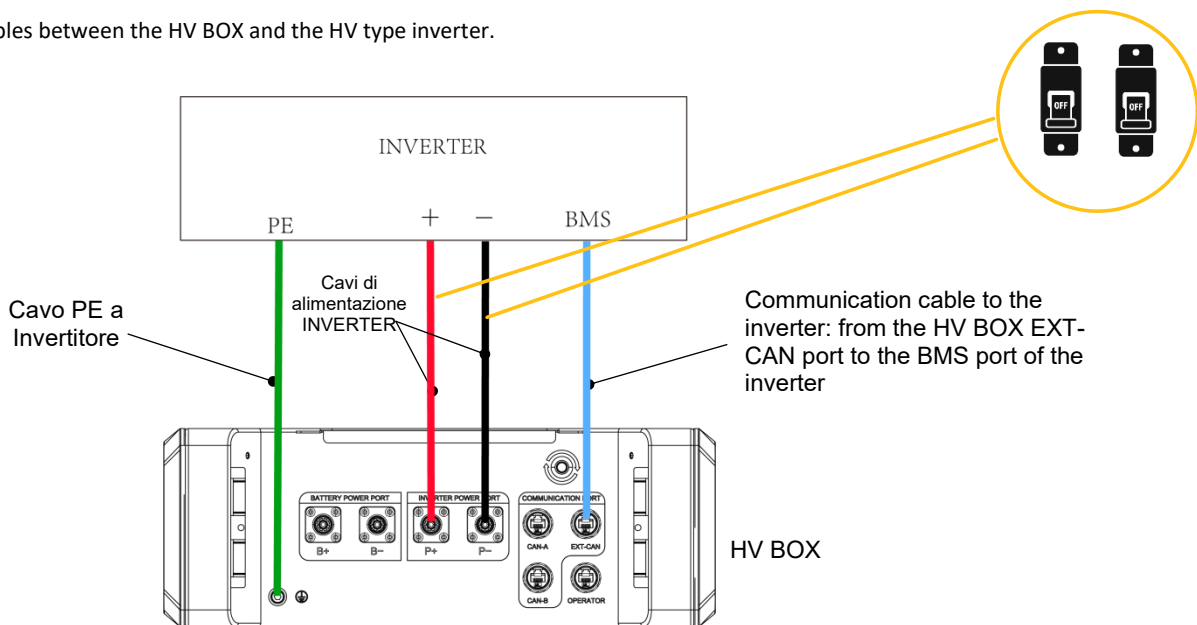

**Caution:** The CAN interface of the BMS is an RJ45 port with the definition of the EXT-CAN as shown below

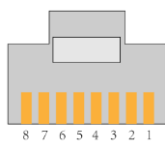

PIN	8	7	6	5	4	3	2	1
Definition							CAN_L	CAN_H



**Attention**

After connecting all cables, tighten the waterproof RJ45 male connectors to the EXT-CAN/CAN A/CAN B module of the HV module and to all battery modules.



**Attention**

If there are two stackable towers, use the cable cover unit (accessory) to secure the cable connection between two towers as follows.

Remove the base cover

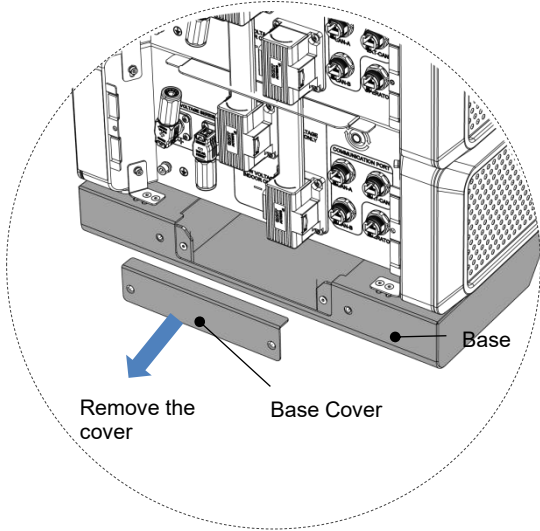

Install the cable cover unit

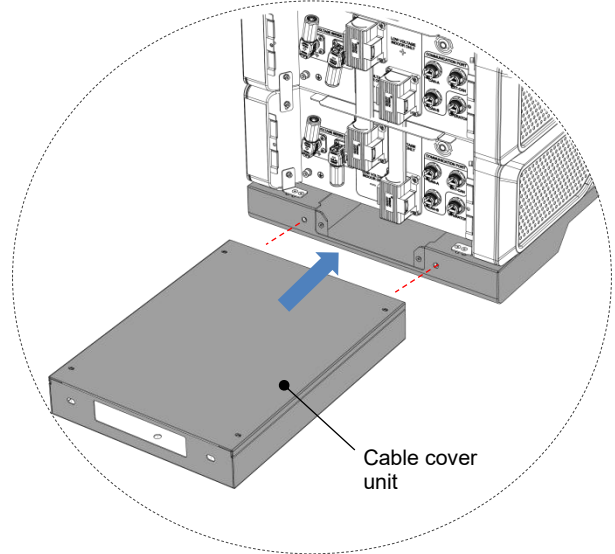

Route all cables that need to be connected to another tower through the cable cover unit that is used to protect the cable connection.

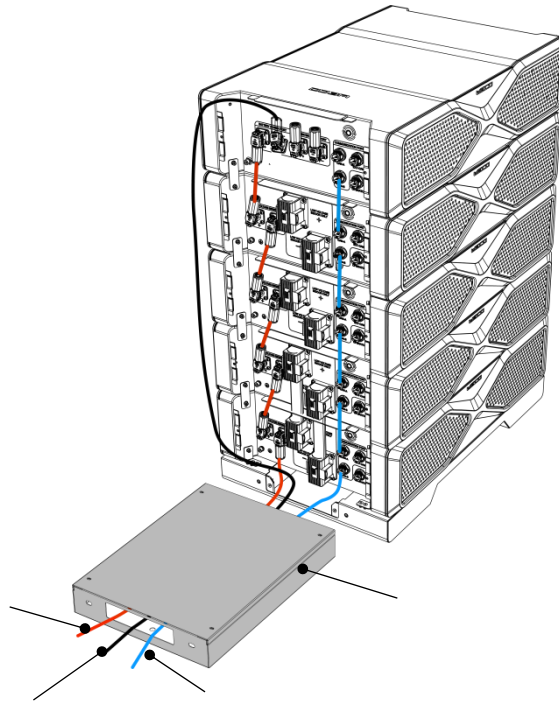

## 5.6 System commissioning

### 5.6.1 Pre-commission check

Serial number	Control	Acceptance criteria
1	The inverter used to connect to the battery module is installed in place	The inverter is installed correctly and is robust and reliable.
2	Wi-Fi antenna is in place	Wi-Fi antennas are installed and connected to the cloud
3	The cables are well arranged	The cable layout is reasonable to meet the needs of the user and current regulations
4	Secure cable attachment	The cable tie is compliant, uniform and has no sharp edges
5	Reliable grounding	The ground wire connection is correct and verified
6	Unplug the switch	The Control Module Power Switch and all switches connected to the battery modules are in the "OFF" state.
7	Cable connections in place	DC power cables, DC output cables, communication cables are connected correctly, safely and reliably.
8	Seal unused terminals and connectors	Unused terminals and connections are covered by waterproof covers.
9	The installation environment meets the requirements	The installation space is correct and approved by the person in charge and/or in charge of the works, the environment is clean and tidy and there are no construction residues.

### 5.6.2 System Startup

After the batteries and the HV box have been installed, and the electrical connection is successfully terminated:

**STEP 1:** Turn on the switch of the HV BOX, then press the run button of the HV BOX module, the system will activate. Check that the display panel lights up and when the WIFI icon LED is solid, use the mobile phone and open the WECO Bluetooth app to connect to the system, then select <HV Module> to enter the home page (refer to chapter 7 for more details):

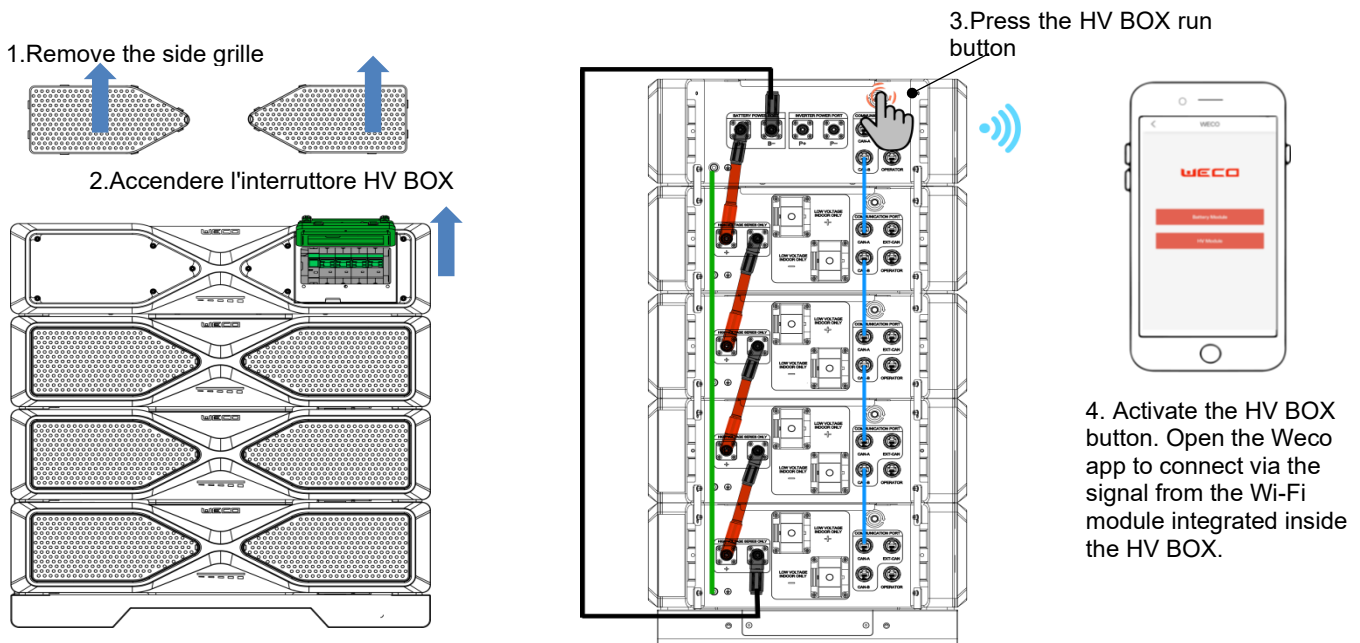

The LED bar of the HV BOX can indicate the battery SOC status and alarm statuses by showing a combination of different colors. The LED bar consists of LED 1 to LED 5 as shown in the figure below.

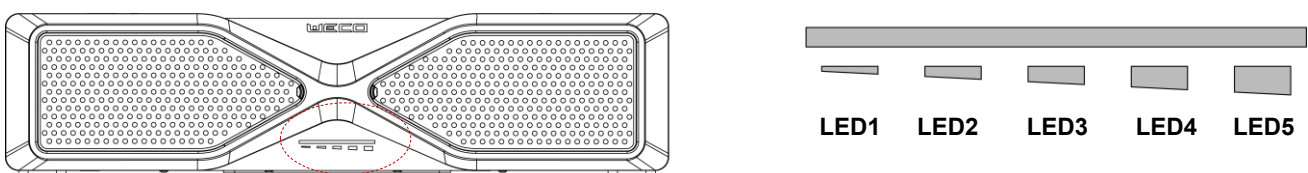

## LED ALARMS AND SAFETY INSTRUCTIONS

LED VISION	DESCRIPTION	MEANING
	Led1~Led5 are green, not flashing.	SOC status indication: 98%≤SOC ≤100%
	Led1~Led4 are green, not flashing.	SOC status indication: 80%≤SOC <98%
	Led1~Led3 are green, not flashing.	SOC status indication: 60%≤SOC <80%
	Led1~Led2 are green, not flashing.	SOC status indication: 40%≤SOC <60%
	The LEDs1 are green, not flashing.	SOC status indication: 20%≤SOC <40%
	LED1 are yellow, not flashing.	SOC status indication: 5%≤SOC <20%
	Led1 are red, not flashing.	SOC status indication: 0%≤SOC <5%
	All LEDs are blue, not flashing.	Starting the ON system
	All LEDs flash red every 1 second. ( <b>call for service do not restart, disconnect inverter from battery system</b> )	Critical Faults: (System locked - requires manual intervention to unlock): 1. Charge/discharge overcurrent 2. Charge/discharge overvoltage 3. Charge/discharge overtemperature
	All LEDs are constantly red. ( <b>call for service do not restart, disconnect inverter from battery system</b> )	System faults (contactor disconnect system failure caused by over-temperature/over-current/over-voltage/under-voltage/under-temperature, etc.): Level 3 Charge/discharge overcurrent Level 3 Cell/Total Voltage Charge/Discharge Overvoltage/Undervoltage Level 2 Over-temperature/Low charge/discharge temperature Heating element failure 1. Contactor failure
	All LEDs are constantly yellow.	System Errors (System Failure Due to Communication Issues): External inverter communication error 1. Internal communication error
	Led5 is constantly blue.	During the firmware update

### SAFETY WARNING

Do not turn on, operate, or service a battery that:

**Generated a blocking alarm;** or has exceeded the operating limits allowed by the Manual (use or storage).

**Restoration:** allowed only after technical inspection and written authorization from the Safety/Quality Manager.

This warning applies if the battery shows a blocking/latching alarm, and/or visible damage, signs of overheating/venting/liquid ingress/impact, or has been used, stored, installed, or transported outside the limits stated in this Manual and the Technical Data Sheet ("out-of-spec use").

Immediate duty to stop using the unit, isolate it, and keep people away.

**Do not energize, service, move, or transport the battery that has experienced a red LED bar Alarm, -shut off and isolate the battery-**

You must contact WeCo or an authorized service partner without undue delay and follow their instructions.

In case of heat, smoke, odor, flames, or other imminent hazards, call local emergency services first and then notify WeCo and the installer. Operation contrary to this Manual—including failure to notify WeCo after an alarm, bypassing protections/BMS, forced charging from extreme under-voltage, tampering, or transport/handling by non-qualified persons—**constitutes misuse and a legal breach.**

To the maximum extent permitted by EU law, WeCo shall not be liable for any loss, damage, injury, or expense arising from misuse or out-of-spec use, and may suspend or deny commercial warranty for resulting failures.

Damaged or out-of-spec batteries must be handled and disposed of only by authorized operators in accordance with applicable EU and national rules (including battery and dangerous-goods requirements).

**Do not attempt repair, reuse, or harvest parts.**

Nothing in this notice limits non-excludable rights under EU consumer law (including remedies for lack of conformity) or non-excludable liabilities under EU product-liability rules for defective products. Where national law prohibits limitation for certain damages (e.g., death or personal injury caused by negligence), those limitations do not apply.

Reactivation is permitted only after a documented technical inspection and written authorization from the safety officer or installer or an authorized service partner that inspect the battery on behalf of WeCo confirming safe, compliant conditions for operations.

WeCo is always available for inspect your battery, you can ship it using an ADR compliant BOX if the safety inspector allows the road transport or as a alternative WeCo can arrange a specific transport with ADR Safe box for Damaged batteries and make an inspection to the WeCo Labs in Italy

**It is forbidden to move or transport the unit until technical evaluation and remediation.**

In case of any doubt or emergency, immediately contact a company specialized in emergency management on lithium batteries/dangerous goods and follow the HSE instructions of the company and the competent authorities (Fire Brigade/local emergency services).

**In case of needs, Secure the area:** apply LOTO on all power supplies, delimit the perimeter, provide ventilation if necessary

**Signage:** affix clearly visible notices ("DANGER – Battery in abnormal state. No access/reactivation")

**STEP 2:** After entering the home page of the WECO Bluetooth or WeCo NOOR app, click  to set the configuration of WIFI networks: Make sure the wifi frequency band is 2.4G and enter the SSID and password as follows:

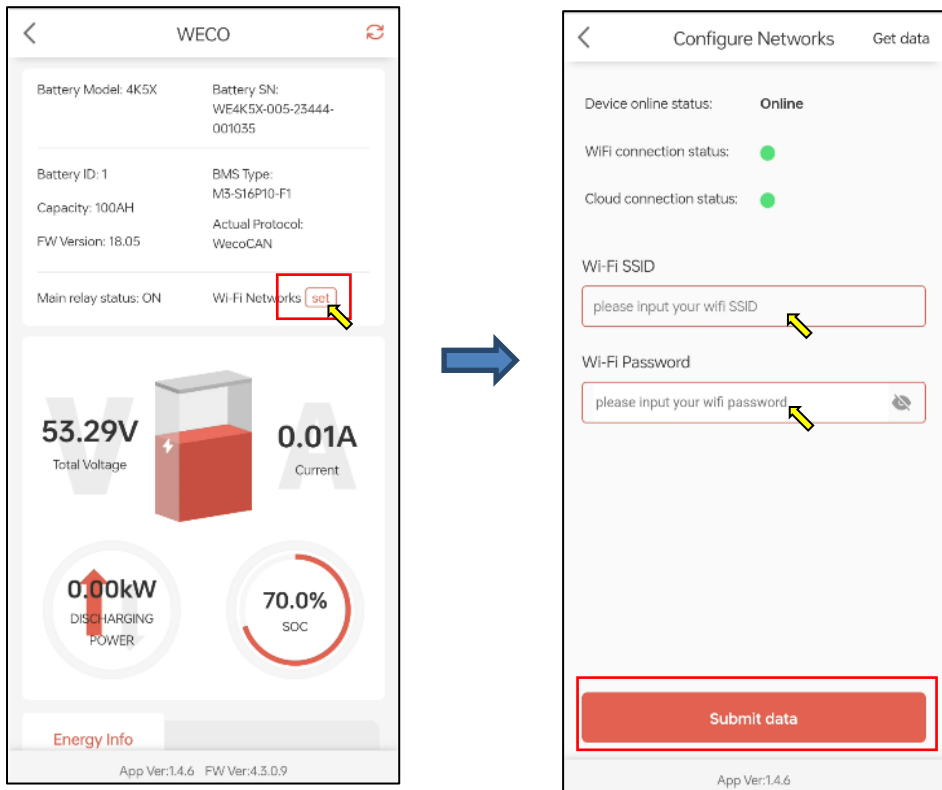

**STEP 3:** Set the protocol according to the inverter brand used to connect with the 5K3-EVO (refer to *Appendix C* for compatible inverter reference and protocol selection) as follows:

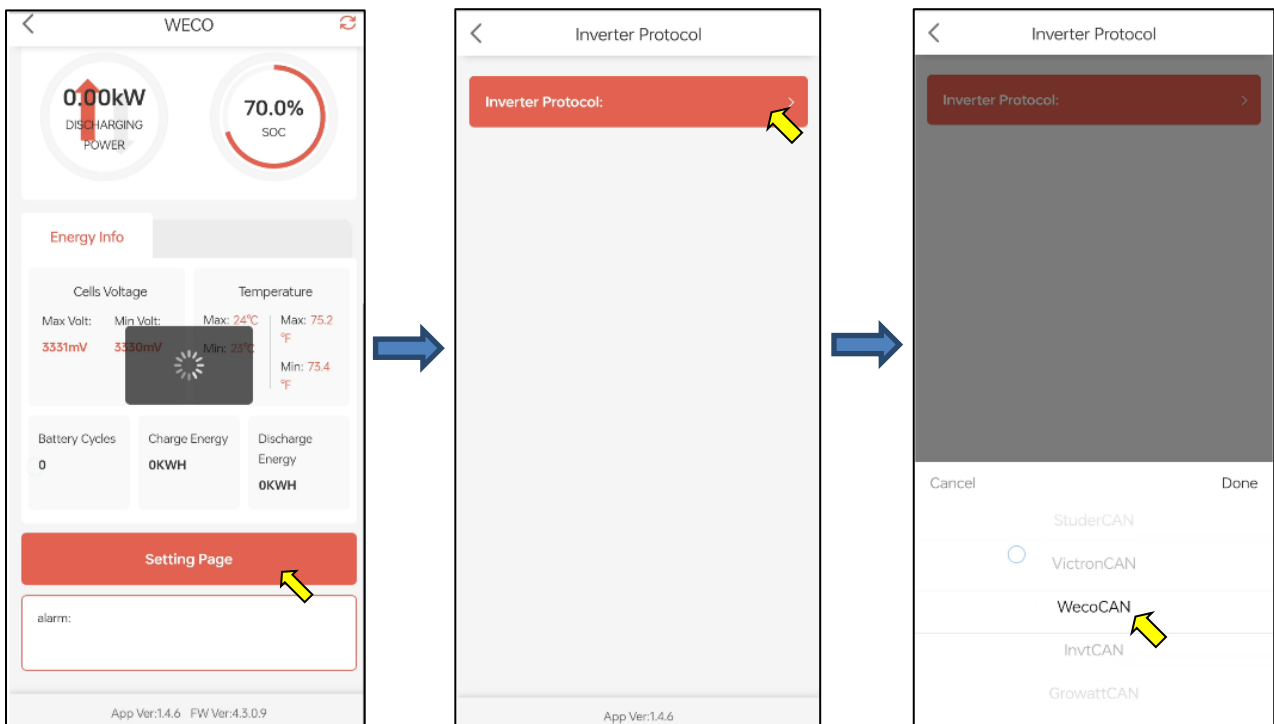

**STEP 4:** After finishing the battery setup, configure the inverter according to the inverter manufacturer's instructions.



WARNING

Make sure the inverter to be connected is compatible with the 5K3-EVO HV module, make sure the DC voltage of the 5K3-EVO is within the allowed range of the inverter, make sure the inverter and battery protocol setting is selected correctly, make sure the battery FW is the last.

After installing the battery and inverter and configuring the batteries and inverter correctly

The system starts in this order: Battery → Turn on the main control module switch → Inverter;

The system shuts down in this order: Inverter → Battery → Turn off the master control module switch;

### 5.6.3 System Deactivation



WARNING

**Risk of injury due to the heavy weight of the battery modules.**  
**At least two operators are required to work and use the lifting machine to move the tower modules. This operation may only be performed by specialized personnel who meet the legal requirements.**



**SAFETY WARNINGS**  
**SHOCK AND ARC FLASH HAZARD.**

#### Step 1 – Inverter shutdown

Turn off the inverter according to the manufacturer's manual (controlled shutdown). Wait for confirmation of the "off" display/indicator lights. Check the absence of DC voltage at the inverter terminals (measurement < 30 VDC) before proceeding.

#### Step 2 – Battery (HV BOX and modules)

Open the HV BOX (breaker/disconnector) hand switch. Apply LOTO. Turn off each battery module according to the procedure (module key/switch). If equipped, open the DC switch between the inverter and the battery system (external disconnect switch).

#### Step 3 – Cables Disconnections

Disconnect the DC cables between the inverter and the batteries. Immediately afterwards apply caps/connector covers.

Disconnect the communication cables (CAN/RS485) and signal grounding if provided. Check with a multimeter for the absence of voltage on the battery side and inverter side connectors.

#### Step 4 – Equipment Removal

Remove the HV BOX. Remove the battery modules from the tower from top to bottom, one at a time, maintaining the mechanical stability of the structure. Use lifting aids if necessary.

#### Step 5 – Post-deactivation

If the modules are to be stored, follow Chapter 8 – Storage (SOC, temperature, packaging).

If the modules are to be disposed of, follow Chapter 10 – Disposal/Recycling and Local Regulations.

Remove LOTO only at the end of the activity and after verifying that the system remains in safe condition.

## 6. WECO WIFI App Operation

### 6.1 App Introduction

#### 6.1.1 Copyright Notice

The copyright in this manual belongs to WeCo and any unauthorized copying and extraction, transmission in any form and other infringement must not be made without the knowledge or permission of the Company. WeCo will pursue the violation to the end. WeCo reserves the right of final interpretation of this manual and if the functions/pages of the WeCo Wi-Fi App are changed, the latest company information will prevail.

#### 6.1.2 Manual Contents

This manual introduces the introduction of the functions and operation process of the WeCo Wi-Fi app, to facilitate users to use and manage the WeCo Wi-Fi app and meet the needs of users.

#### 6.1.3 Manual Instructions

Dear users, thank you very much for using WECO's smart monitoring APP, we sincerely hope this product meets your needs. The purpose of this manual is to provide users with detailed product information and operating instructions.

#### 6.1.4 Usage Requirements

Download method: Google Play, App Store app market search for "WeCo Wi-Fi".



#### Apple wifi    Android wifi

Download the WECO WIFI app and install it on your mobile phone.



#### 6.1.5 Registering a WECO WIFI APP Account

If you don't have a WeCo Wi-Fi app user account, follow the steps below to sign up.

Procedure:

1. On the WeCo Wi-Fi App login page, click "REGISTER".
2. Follow the instructions on the page to complete the user account registration.
3. After the account is successfully registered, the user can log in to the WeCo Wi-Fi app with the registered account and password.

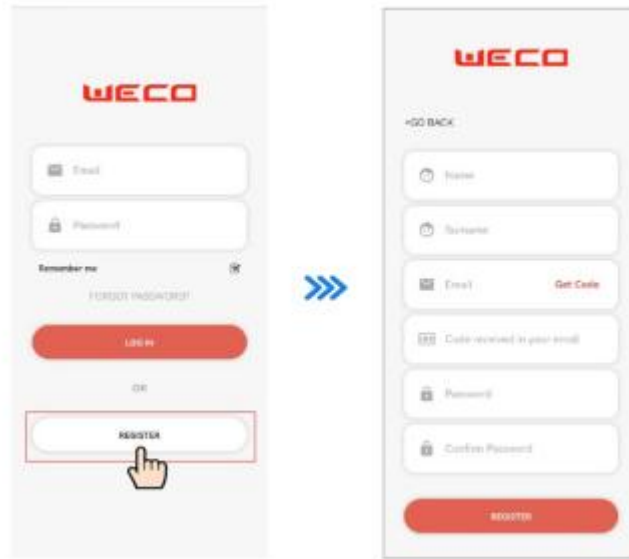

## 6.2 Log in and Disconnect the APP

### 6.2.1 Log in to the APP

After the app is successfully installed on your phone, log in to the app to use it.

Method:

1. On the desktop of the mobile client, click the WeCo Wi-Fi App icon to enter the login page.
2. On the app login page, enter your account number and password, then click "Login".

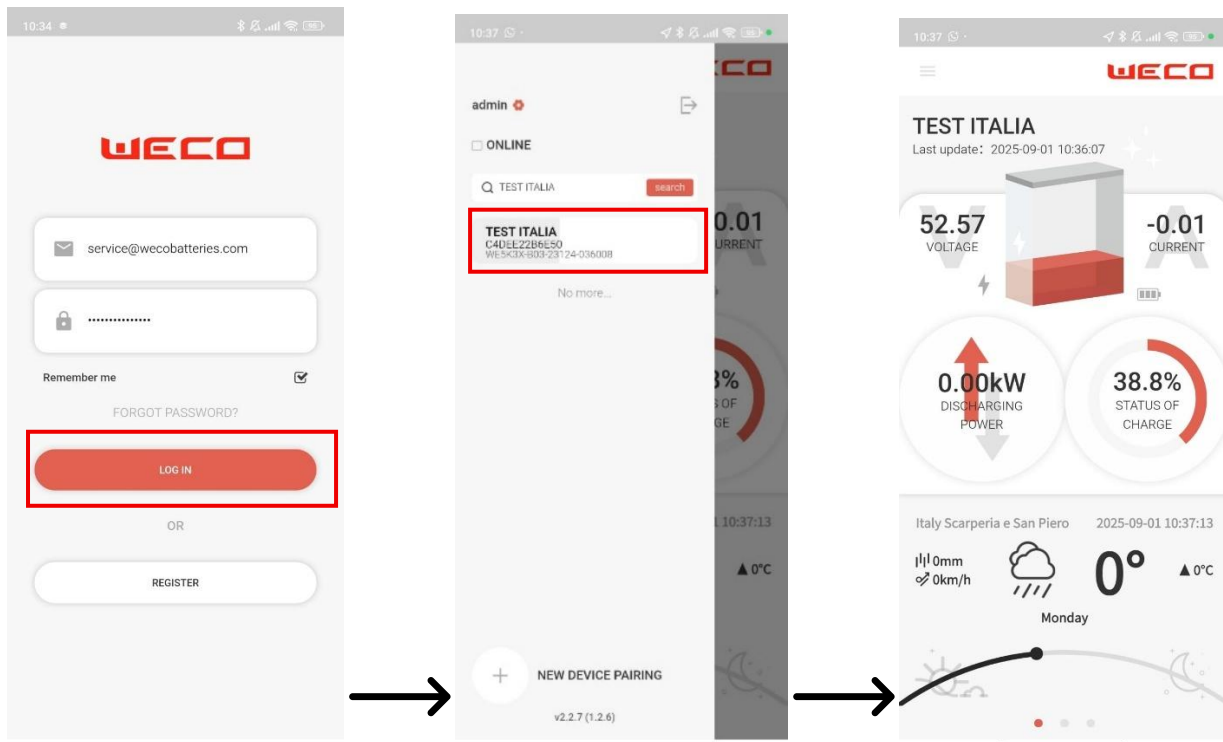

## 6.2.2 Logout from the APP

Procedure:

1. On the top left area of the homepage, click the "☰" icon to bring up the page on the left.
2. Click on "👉" and you will log out the app.

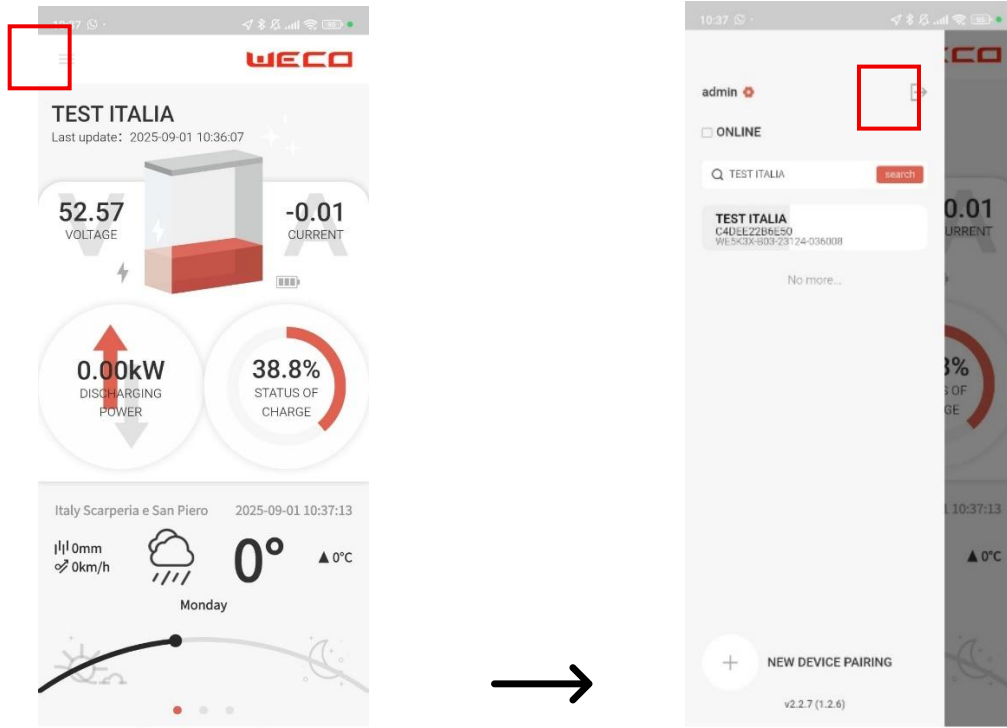

## 6.3 Add the first device

Procedure:

1. After logging in to the APP, click "ADD NEW DEVICE".
2. Go to the add device page, here you can click "SCAN" to scan the QR code on the device or click "DEVICE LIST" to select the device for Bluetooth connection.
3. Enter the "Configure Wi-Fi" window, select 2.4G Wi-Fi, enter the password, and click "CONFIGURE" to configure the network.
4. After successfully configuring the network, enter the "Device Info" page, enter the information according to the prompts on the page, click "Save settings" to save the information, and automatically return to the home page.



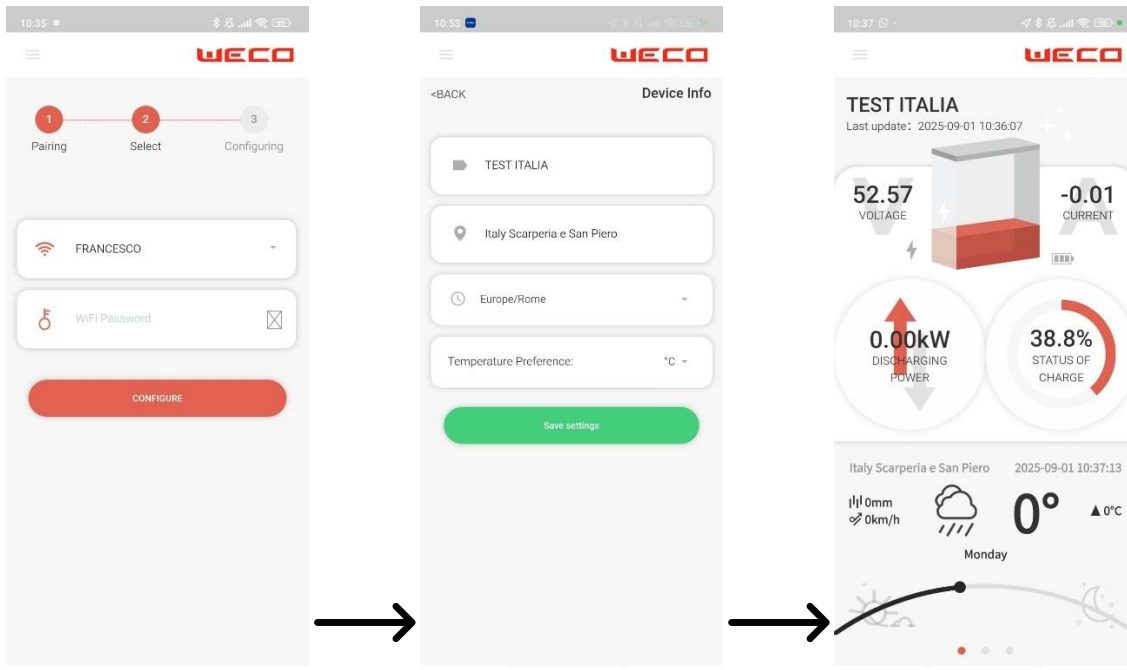

### 6.3.1 Add another device

Procedure:

1. In the upper left area of the home page, click the "+" icon to bring up the page on the left.

2. Click "☰" to go to the Add Device page.

3. Go to the Add Device page, here you can click "SCAN" to scan the QR code on the device or click "DEVICE LIST" to select the device for Bluetooth connection.

4. Enter the "Configure Wi-Fi" window, select the 2.4G Wi-Fi, enter the password, and click "CONFIGURE" to configure the network.

5. After successfully configuring the network, enter the "Device Info" page, fill in the information according to the instructions on the page, click "Save settings" to save the information, and automatically return to the home page.

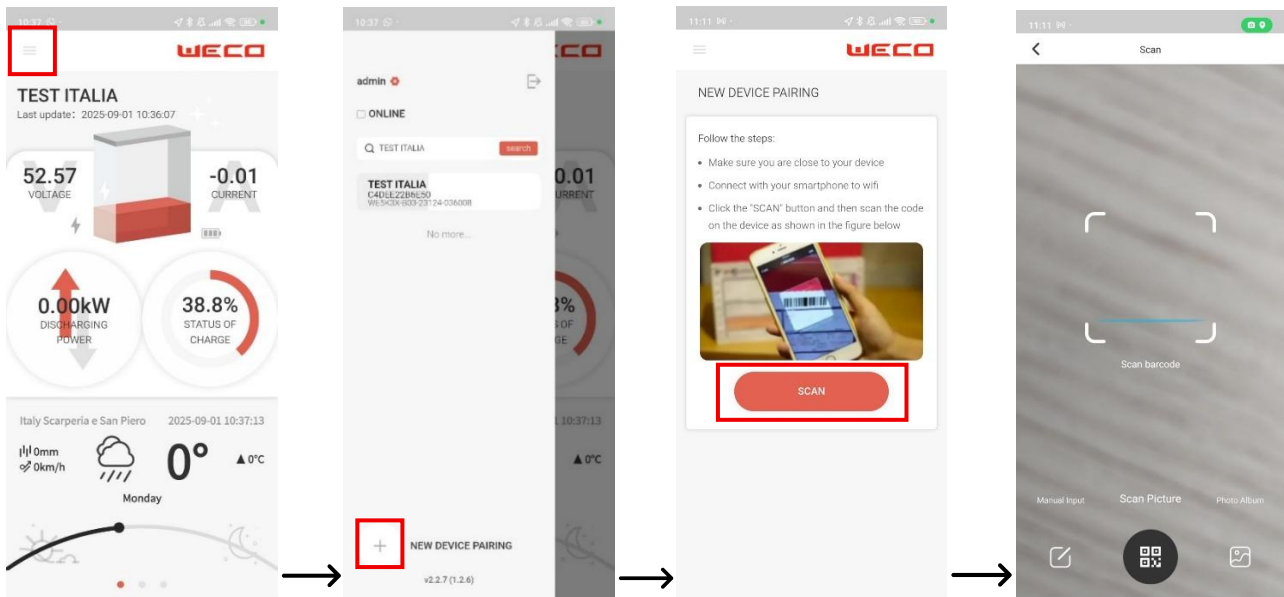

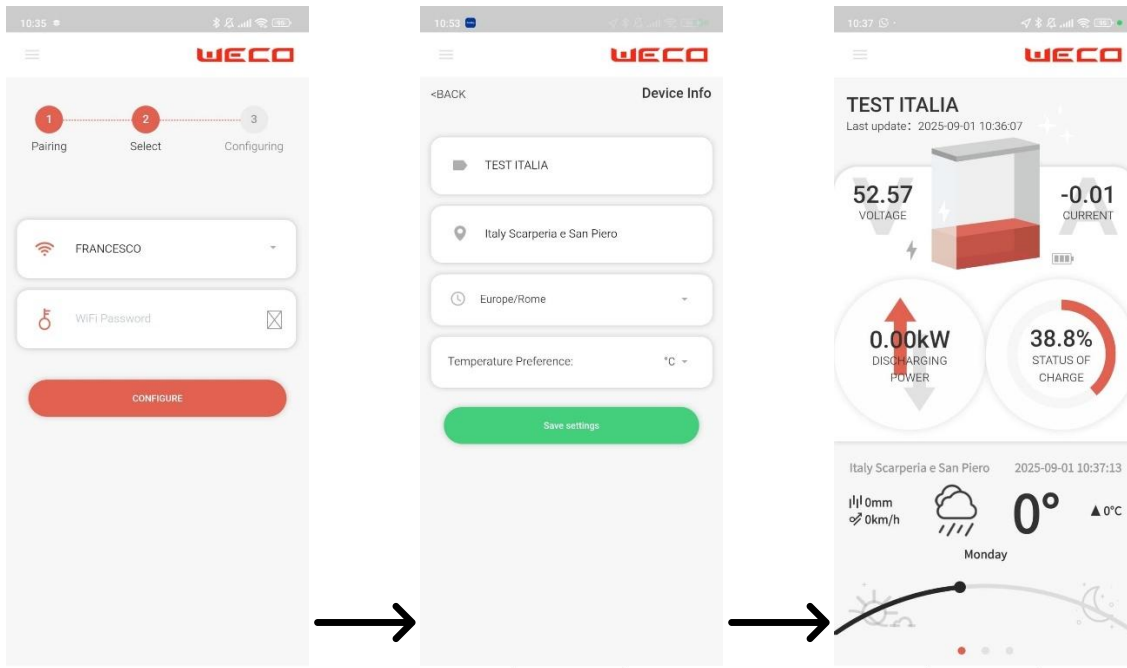

### 6.3.2 Display Device

After logging in to the app, you can select the device you want to view on the pop-up on the left.

### 6.3.3 Display the main parameters of the device

Procedure:

1. After logging into the app, select the device you want to view on the left.

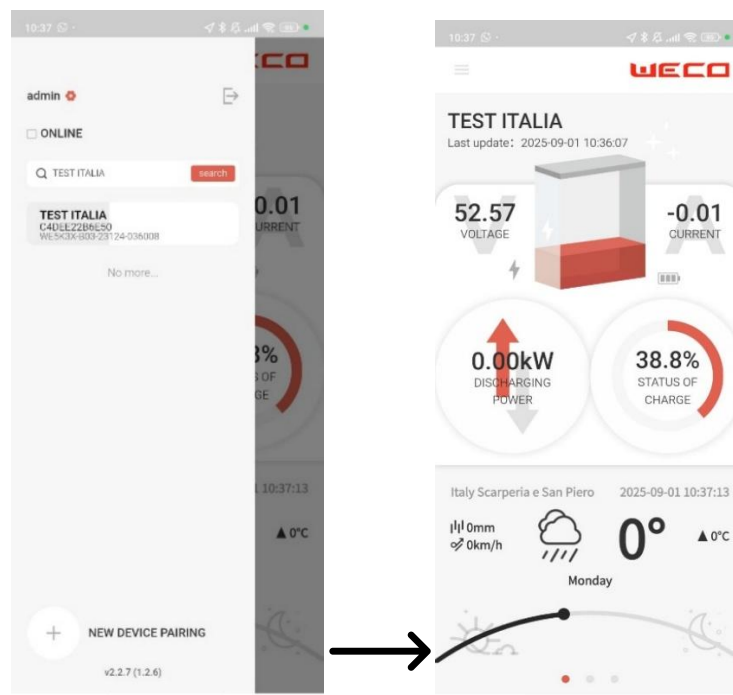

### 6.3.4 Viewing Trend Charts

Procedure:

1. After logging into the app, select the device you want to view on the left.
2. After entering the main parameters page, "swipe left" to enter the trend chart page.

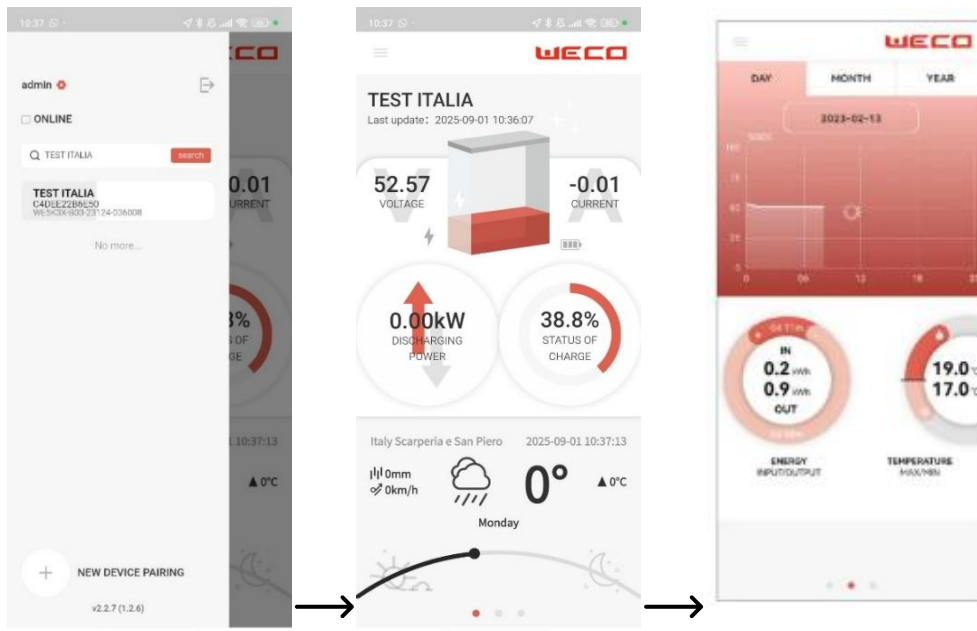

### 6.3.5 Display Detailed Device Parameters

Procedure:

1. After logging into the app, select the device you want to view on the left.
2. After entering the main parameters page, "swipe left" to enter the trend chart page.
3. Swipe left again to enter the device details page.

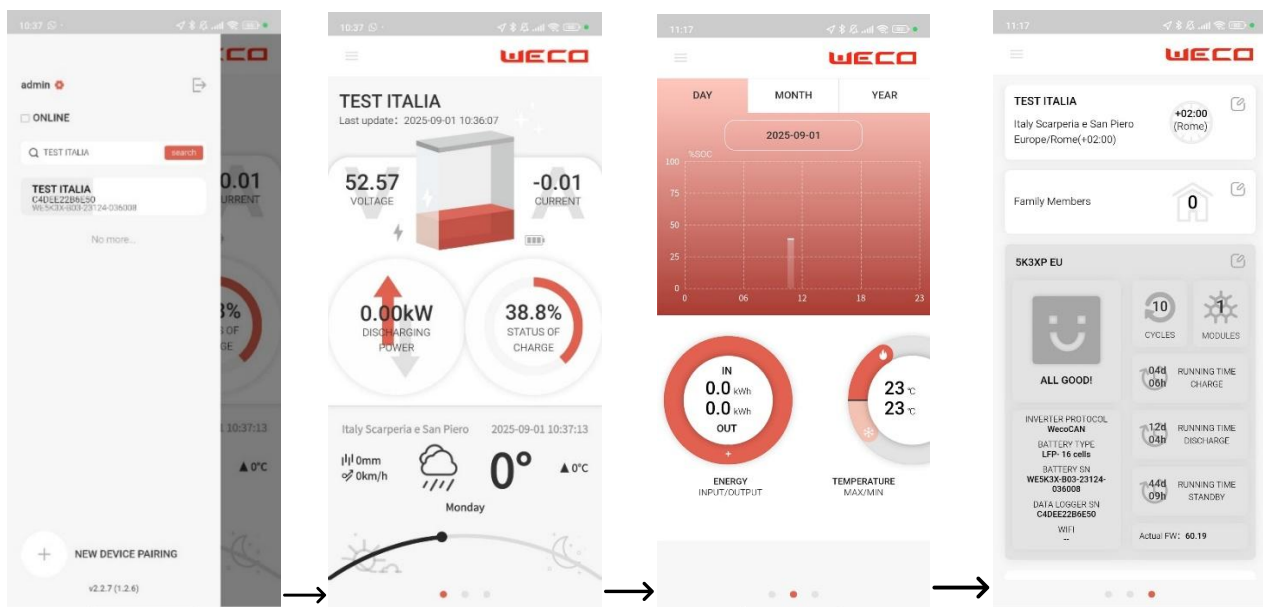

## 6.4 Frequently Asked Questions

### 6.4.1 How to reset your password by email if you have forgotten it?

Prerequisite: The user's email address can receive the verification code.

Procedure:

1. On the app login page, click on "Forgot your password?" "Go to the Forgot Password page.
2. Enter your email account.
3. Click "Get verification code" and enter the verification code to verify the email account.
4. When prompted to enter a new password and re-enter the new password, click "Confirm".

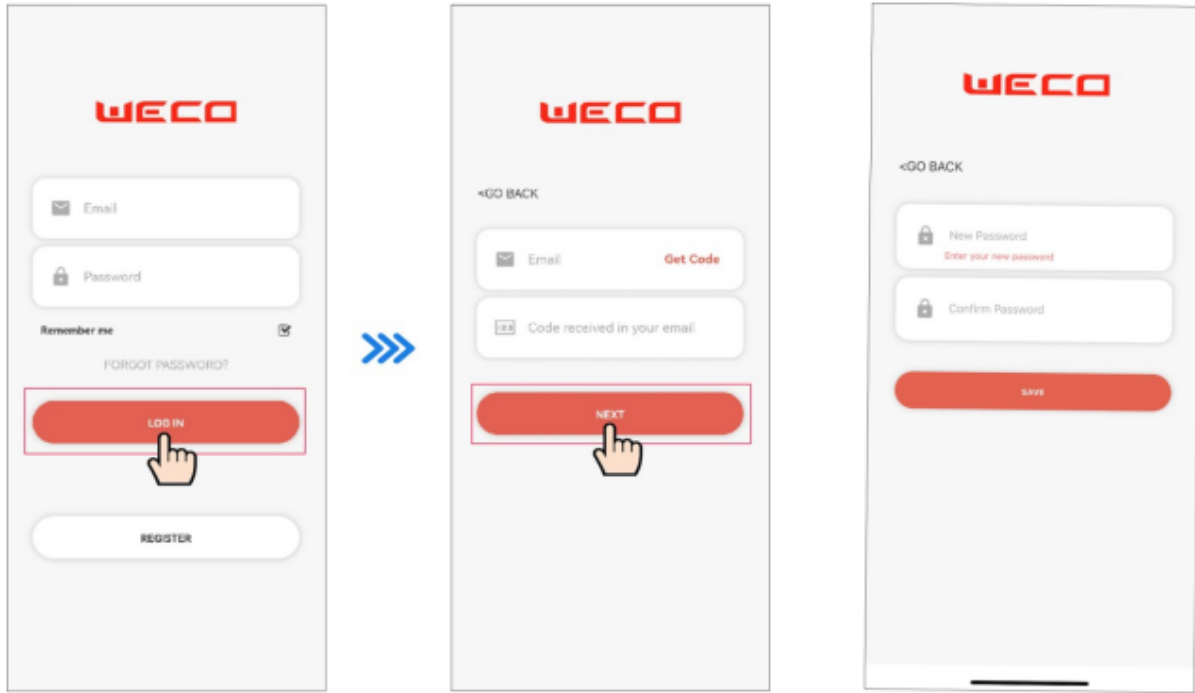

### 6.4.2 Resetting the user's password

When the user is unable to reset the forgotten password, they can authorize their administrator to reset it.

### 6.4.3 When the user logs in to the app, asks how to fix the network anomaly?

Work around:

- Check if the Wi-Fi or mobile network connection is working.
- Check if network permission is enabled for the app.

### 6.4.4 Device Not Displayed After Adding

After the device is added, it does not appear in the device list.

Workaround:

- Please check whether the device communication or network connection is normal, if it is normal, please wait for a few minutes.
- If there is an abnormality in the control, please contact the service provider.

### 6.4.5 Network Changes: How to Reconfigure Device Network

Prerequisite: The user's email address can receive the verification code.

Procedure:

1. On the Device Details page, click the parameters icon.
2. After entering the Wi-Fi Settings page, click "Change Wi-Fi" to enter the Configure Wi-Fi page.
3. Select the 2.4G Wi-Fi according to the instructions on the page, enter the password and click "CONFIGURE" to configure the network.

## 7. WECO Bluetooth App Operation

### 7.1 App Introduction

#### 7.1.1 Copyright Notice

The copyright in this manual belongs to WeCo and any unauthorized copying and extraction, transmission in any form and other infringement must not be made without the knowledge or permission of the Company. WeCo will pursue the violation to the end. WeCo reserves the right of final interpretation of this manual and if the functions/pages of the WeCo Wi-Fi App are changed, the latest company information will prevail.

#### 7.1.2 Manual Content

This manual introduces the introduction of the functions and operation process of the WeCo Bluetooth app, to facilitate users to use and manage the WeCo Bluetooth app and meet the needs of users.

#### 7.1.3 Manual Instructions

Dear users, thank you for using WECO's smart monitoring APP, we sincerely hope this product meets your needs. The purpose of this manual is to provide users with detailed product information and operating instructions.

#### 7.1.4 Usage Requirement

Download method: Google play, App Store app market search "WeCo Bluetooth".



#### Apple wifi    Android wifi

Download the WECO Bluetooth app and install it on your mobile phone.

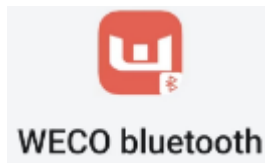

Information

Download the WECO NOOR app and install it on your mobile phone. The WECO app has a similar function to the WECO WIFI app. The WECO Bluetooth APP is intended for use when the battery module is near a mobile phone used to run the WECO Bluetooth APP. And it is recommended in case rather than using the WECO WIFI APP. The following WECO Bluetooth operations are for reference, the battery example could be another WECO model.

## 7.2 Log in and log out the APP

### 7.2.1 Log in to the APP

After the app is successfully installed on your phone, log in to the app to use it.

Procedure:

1. On the mobile client desktop, click the WeCo Bluetooth App application icon to enter the login page.
2. On the app login page, enter your password and click "Login".
3. On the pop-up page, click "HV BOX" for HV system.
4. On the Devices page, select the related device and click on it to enter the home page.

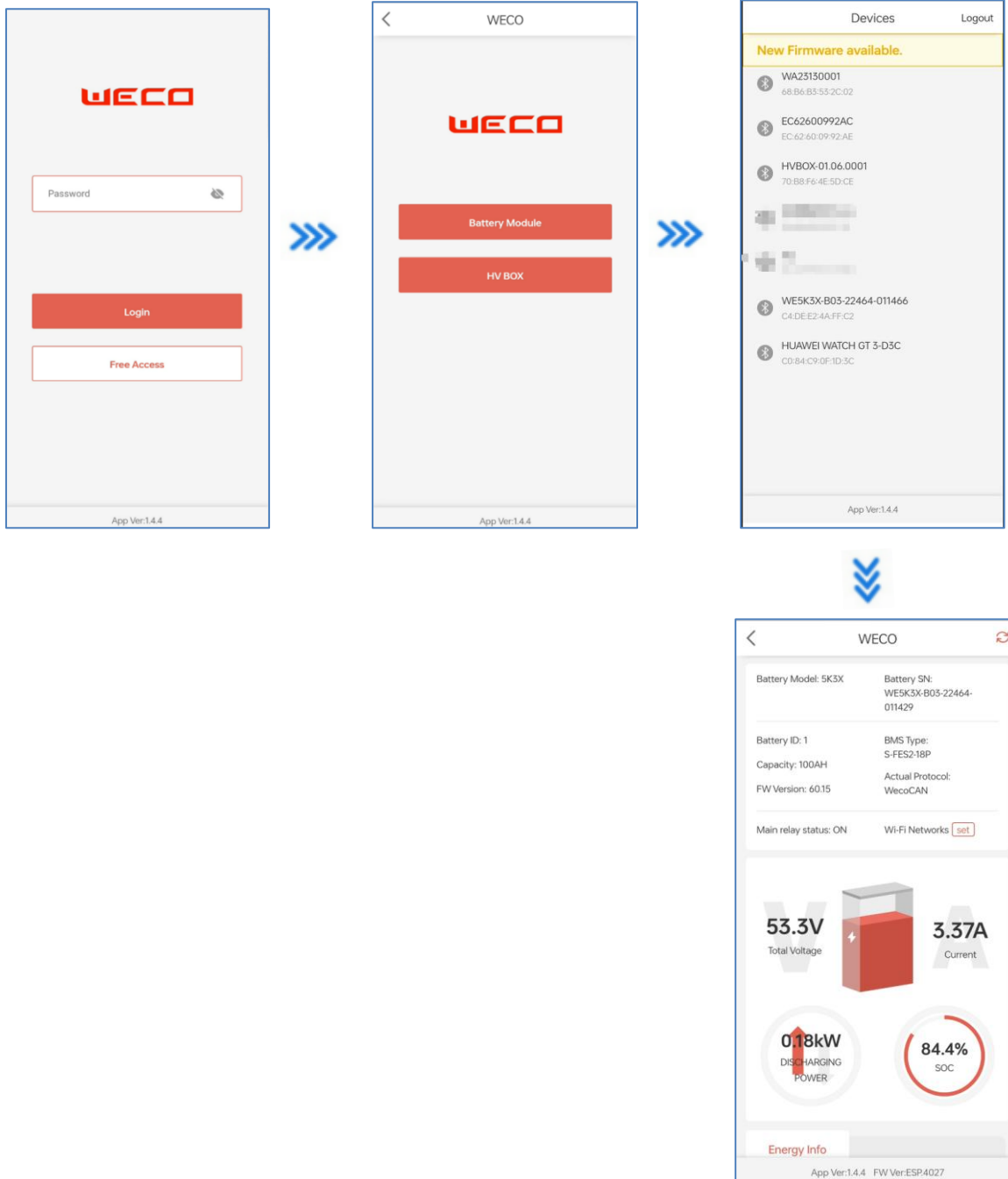

### Information

Contact your WECO company to acquire your password. It can be accessed by clicking "Free Access", but the setting function will not be available, "Free Access" Login is only for Device Status Check.

## 7.2.2 Exit the APP

Procedure:

1. In the upper-left area of the homepage, click “” icon to bring up the page on the left.
2. Click "Sign Out" and you will log out of the app.

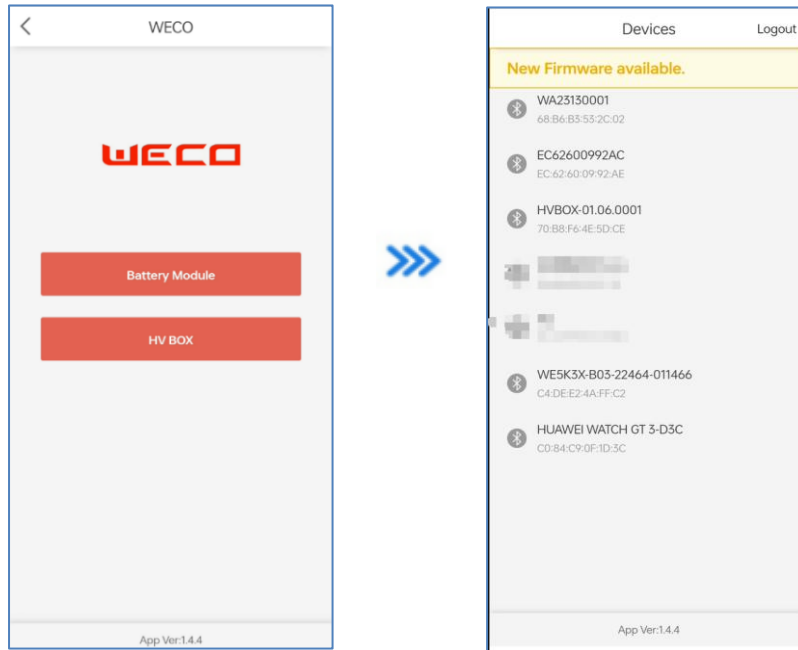

## 7.3 View Device and Setup

### 7.3.1 Display the main parameters of the device

Procedure:

1. After logging in to the app, the home page will be displayed directly, you can directly view the main parameters of the battery.

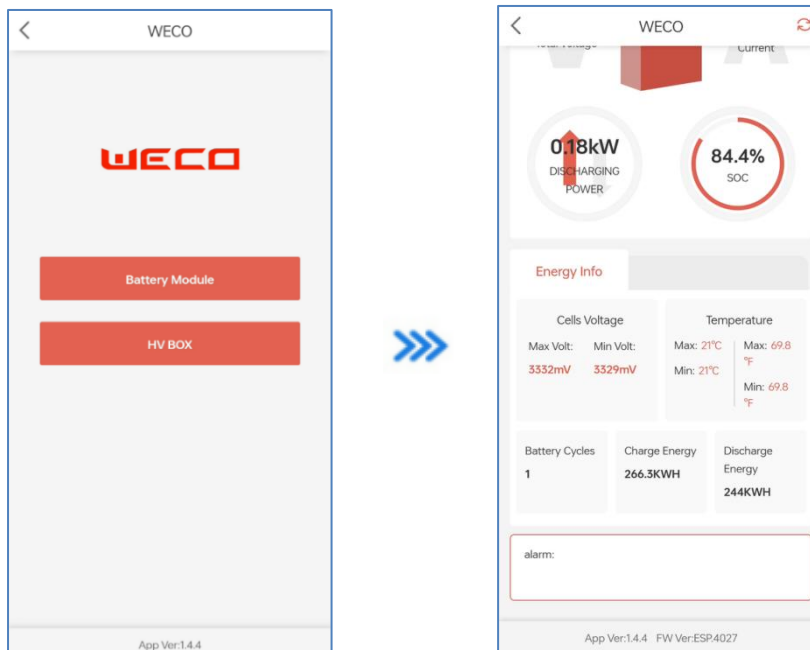

### 7.3.2 Set the Battery Protocol

Procedure:

1. Click "Setting Page" at the bottom of the home page.
2. After entering the pop-up page, click the inverter protocol to select the correct protocol for the inverter connected to the battery.

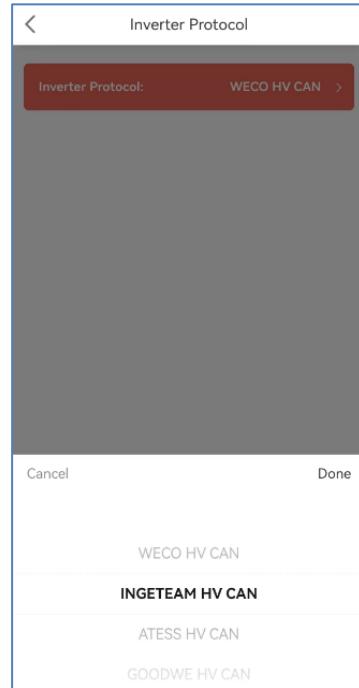
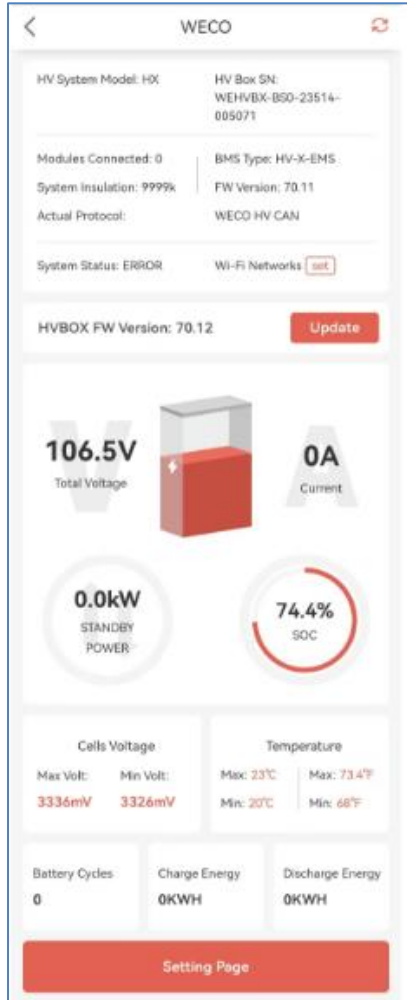

### 7.3.3 Always update the firmware to the latest version

Procedure:

1. Click "Update" in the middle of the home page.
2. Then the inverter will start updating to the indicated version.

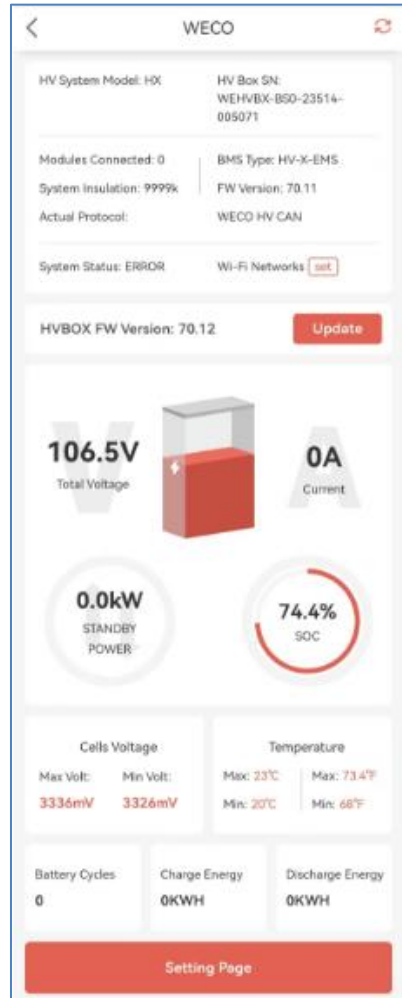

## 8. Storage

### 8.1 Storage - Transport - Removal / Transfer of batteries

This battery is considered a DANGEROUS GOOD by the United Nations and should be treated accordingly. Each box leaves the factory with the following labels:



This battery can only be transported and stored with the original approved cardboard box, certified according to UN CLASS 9 Y80. This battery should be stored in its original cardboard box in a dry and cool place. The box of

Carton is marked as below:



The Transport and Storage State of Charge (SoC) must not exceed 50%.

The storage period without recharging is 6 months and therefore requires fast charging up to 50% DoD. Charge to 0.1C and not more than 50% SOC. In the case of shipping by sea, reference must be made to the UN38.3 standard. If you are traveling by road, please refer to local regulations.

To preserve performance and shelf life, this battery should be optimally stored at 77°F /25°F and @70% humidity.

The acceptable storage temperature range of the battery is +59°F to +95°F /+15°C to +35°C

Self-discharge in the range of +59°F to +119°F /+15°C to +35°C is approximately 1% per month. Anything outside of this range could exceed 10% per month.

Do not store batteries near sources of heat, steam, gas, fuels, sparks, or anything that may cause a fire or explosion.

Store indoors and protect from water and moisture.

The transport of new and used or damaged modules must comply with UN 38.3 and federal, state, and local regulations.

If one or more working battery modules need to be removed or replaced, they must be marked as USED BATTERY (follow local rules).

If one or more battery modules need to be replaced due to damage, they must be marked as DAMAGED USED BATTERY and follow all applicable procedures and all federal, state, and local regulations.

## 9. Maintenance and Replacement

Please follow the following instructions for battery maintenance and replacement:

- Maintenance of the battery module must be carried out by operators who are well trained and authorized by the company WECO.
- The battery module must be turned off before servicing and follow the safety instructions in this manual and other relevant documents.
- Do not restart the battery unless all faults have been resolved.
- After maintenance is complete, check that there are no parts left in the battery module.
- Do not disassemble without permission from WECO as there is a risk of electric shock. Any damage due to the above reason is not covered by the warranty.
- When not using the battery for a long time, store and charge the battery according to the instructions in this manual.

## 10. Battery Module Disposal

### 10.1 Remove the Battery

Procedure

Step 1: Perform the system shutdown operation

Step 2: Disconnect all electrical connections to the battery modules.

Step 3: Remove the battery module.



#### Attention

Please note that, for any reason, personnel or installer will not disassemble the battery module without WECO's authorization, otherwise the device will no longer be under warranty.

### 10.2 Packing the Batteries

Please put it inside the original packaging and seal the package tightly with tape

### 10.3 Dispose Batteries

Disposal of the battery module must comply with local regulations associated with the regulations on the disposal of electronic waste and used batteries.

## Appendix A Battery Module Technical Parameters

Technical Performance	
System Model	5K3-EVO
Voltage rating	51.2V
Cell Module	1P16S (1P8S*2=A+B MODULE)
Cell Module	16
Voltage range	44.8-57.6V
AH Classification	102Ah
Nominal capacity	5.22kWh
Cell Type	LFP 3.2V/102Ah Li-ion LiFeP4
(70% SOH,25°C,0.5C/0.5C)	8000 cycles
Standard continuous charging current	50A
Standard continuous discharge current	50A
Max. Corrente di carica continua	100A
Maximum continuous discharge current	100A
Maximum number in parallel in a cluster	15
Max. Parallel Number Cluster	7 (via LV hub)
Intervallo di temperatura di carica	0-55°C
Discharge temperature range	-20-55°C
Operating humidity	5~95%
Operating altitude	< 3000 m
Module Heating Methods	Heating Pad with silicon resistor
Module Cooling Methods	Natural cooling
IP Class	IP20 (Low voltage configuration) or IP64 with accessories to be purchased separately IP66 (High voltage configuration)
Installation application	Indoor and outdoor, protected from water, humidity, low and high temperatures, shaded from direct light
Corrosion resistant grade	C3
Battery Size: W×H×D	700*460*165mm
Peso	55KG
SOC at origin	70%

### Storage & Maintenance (Idle Battery/Shelf storage)

Store only within the environmental limits stated in the Technical Data Sheet. If the battery is stocked and not used, **recharge at least every 3 months** and perform **one full charge–discharge cycle every 6 months**.

Prolonged storage without maintenance will cause capacity loss, SOC drift, and may impair BMS functions; **deep self-discharge can irreversibly damage cells**. Operation is required to keep the pack healthy; ignoring these intervals may be considered misuse and can affect warranty coverage as permitted by law.

### BMS RTC Button Cell

The BMS includes an RTC **lithium button cell** (coin cell type 3.2V). Over product life this cell may require replacement. Replacement must be performed **only by authorized personnel** using an equivalent, approved type; dispose of the spent cell per local regulations.

**Depletion of the RTC cell does not compromise core BMS safety protections or battery protection logic**, but may affect clock-based functions ( time-stamping/logging) until replaced, on line connection will ensure the operations and logging even if the button battery is totally discharged

## Appendix B Battery Label

The nameplate label describes the parameters of the product and is attached to the product. For details, refer to the product nameplate

label. For safety reasons, the installer must have a thorough understanding of the contents of this manual before installing the product. The label data may be different from the manual, always refer to the label of the product you purchased.

### WeCo BATTERY MODULE – PRODUCT LABEL



WeCo Srl Viale Kennedy 113-121  
Scarperia e San Piero CAP 50038(FI)

## SK3-EVO

### LITHIUM ION BATTERY

Emergency Number Europe +39 0550105300
www.wecobatteries.com service@wecobatteries.com

Modello/Model	SK3-EVO
Capacità Utile/Net capacity @25°C	102Ah
Energia prodotto/Product Energy	5.22kWh
Tipo Cella/Cell Type	LiFePO <sub>4</sub>
Tensione Nominale/Nominal Voltage	51.2 Vdc
Grado IP/IP Grade	IP66 HV Application only // IP 64 LV application with accessory
Limiti Tensione Protezione del BMS BMS Voltage protection limit	44.8-57.6Vdc
Modi consigliati di caricamento Recommended charging method	CC-CV
Tipologia Batteria/Designation of Battery	IFpP51/161/119[16S]M/-10+50/90
Categoria Prodotto / Goods Category	Dangerous Goods ( DG9)
Classificazione UN / UN Class	UN 3480 LITHIUM ION BATTERIES, 9, (E)
Protective Class	I
Standards	ENIEC 61000-6-1:2019 ENIEC 61000-6-2:2019 ENIEC 61000-6-3:2021 ENIEC 61000-6-4:2019 IEC 62619(CB) IEC 62477-1 RoHS Compliant

Questo prodotto deve essere installato e mantenuto solo da operatori professionali qualificati.  
 Leggere attentamente il Manuale di Uso Manutenzione prima di operare.  
 Il mancato rispetto delle prescrizioni contenute nel manuale fa decadere la garanzia.  
 This product should only be installed and maintained by qualified professional operators.  
 Read the Operation and Maintenance Manual carefully before operating.  
 Failure to follow the instructions in the manual will invalidate the warranty.  
 Este producto solo debe ser instalado y mantenido por operadores profesionales calificados.  
 Lea atentamente el Manual de Uso y Mantenimiento antes de operar.  
 El incumplimiento de las instrucciones contenidas en el manual invalidará la garantía.





Li-ion



RoHS



















































































































































































































































































































































































































































MADE IN CHINA

110.00 mm

90.00 mm

## Appendix C HV Box Technical Parameters

Technical Performance	
Support Operate Voltage Range	80~1000V
MAX Support Charge/Discharge Current	100A
Main Circuit Control	Positive Contactor/Negative Contactor/Precharge Contactor
Main Circuit Protection	DC Breaker with Excitation trip: DC1000V/125A Fuse: DC1000V/160A
Battery communication	CAN1
Upper Computer Communication	RS232
Parallel Communication	CAN2
INV Communication	CAN3
HvBox Dimension: W×H×D	700*460*165mm
Battery Protection	Over Charge/Over Discharge/Over Temperature/Over Current/Short Circuit
Operation Temperature Range	-20°C +60°C
IP Class	IP66
Corrosion-Proof grade	C3
Weight	26kg
Minimum battery in serial	2
Maximum battery in serial	17
Maximum cluster in parallel	10

## Appendix D HV Box Label

The nameplate label describes the parameters of the product and is attached to the product. For details, refer to the product nameplate label. For safety reasons, the installer must have a thorough understanding of the contents of this manual before installing the product. The label data may be different from the manual, always refer to the label of the product you purchased.

### WeCo HV BOX MODULE – PRODUCT LABEL

90.00 mm

110.00 mm



WeCo Srl Viale Kennedy 113-121  
Scarperia e San Piero CAP 50038(FI)

# HV BOX

## 5K3-EVO

www.wecobatteries.com    service@wecobatteries.com	Emergency Number Europe +39 0550105300
Modello/Model	HVBOX-EVO
Intervallo di Tensione Operativa Operating Voltage Range	80-1000Vdc
Corrente Massima per ingresso/Max Current per Input	100A
Corrente Max Carica Scarica/Max Charge Discharge Current	100A
Protezioni di Sicurezza Attiva/Active Safety Protection	150A Contattore Automatico/Automatic Contactor
Protezioni di Sicurezza Passiva/Passive Safety Protection	Fusibile /Fuse 200A/1000Vdc
Sezionatore Generale Manuale/Manual Main Breaker	125A/1000Vdc
Grado IP/IP Grade	IP66
Massima tensione ingresso /Max input voltage	1000Vdc
Temperatura di stoccaggio/Storage Temperature	from -20°C to +55°C
Protective Class	I
Standards	ENIEC 61000-6-1:2019 ENIEC 61000-6-2:2019 ENIEC 61000-6-3:2021 ENIEC 61000-6-4:2019 ENIEC 62477-1

Questo prodotto deve essere installato e mantenuto solo da operatori professionali qualificati.  
 Leggere attentamente il Manuale di Uso Manutenzione prima di operare.  
 Il mancato rispetto delle prescrizioni contenute nel manuale fa decadere la garanzia.  
 This product should only be installed and maintained by qualified professional operators.  
 Read the Operation and Maintenance Manual carefully before operating.  
 Failure to follow the instructions in the manual will invalidate the warranty.  
 Este producto solo debe ser instalado y mantenido por operadores profesionales calificados.  
 Lea atentamente el Manual de Uso y Mantenimiento antes de operar.  
 El incumplimiento de las instrucciones contenidas en el manual invalidará la garantía.





















RISPETTARE LA POLARITA' DELL'HV BOX DALLA STRINGA DI BATTERIE  
 RESPECT THE POLARITY OF THE HV BOX FROM BATTERY STRING

MADE IN CHINA

## Appendix E HV INVERTER COMPATIBILITY

The high-voltage configuration is compatible with the following HV inverters.

Inverter		Protocol selection
	WECO ESS	WECO HV CAN
	Ingeteam	INGETEAM HVCAN
	Solis	SOLIS HV CAN
	Atess	ATESS HV CAN
	DEYE	DEYE HVCAN
		SINECEL HVCAN
		AFORE HVCAN

## Appendix F LV INVERTER COMPATIBILITY

The low-voltage configuration is compatible with the following HV inverters.

Compatibility List of Low Voltage Inverters

Inverter		CAN Terminal	CAN Terminal	Inverter side (PIN number)	Battery side (PIN number)	Battery side (PIN number) Selezione protocollo
	WECO ESS	RJ45	CAN L	5	2	WECOCAN
			CAN H	4	1	
	DEYE	RJ45	CAN L	5	2	DEYECAN
			CAN H	4	1	
	SCHNEIDER	Gateway	CAN L	5	2	CONEXTCAN
			CAN H	4	1	
	SOLIS	RJ45	CAN L	5	2	SOLISCAN
			CAN H	4	1	
	SMA	RJ45	CAN L	5	2	SMACAN
			CAN H	4	1	
			CAN H	/	1	
	VICTRON ENERGY	RJ45	CAN L	8	2	VICTRONCAN
			CAN H	7	1	
	SUNGROW		CAN L	/	2	WECOAN
			CAN H	/	1	
	SOLAX POWER		CAN L	/	2	SOLAXCAN
			CAN H	/	1	
	GOODWE		CAN L	/	2	GOODWECAN
			CAN H	/	1	
	STUDER INNOTECH		CAN L	/	2	STUDERCAN
			CAN H	/	1	
	VOLTRONIC POWER	RJ45	CAN L	7	2	VOLTRONICCAN
			CAN H	6	1	
	INVT MEGA		CAN L	/	2	INVTCAN
			CAN H	/	1	
	GROWATT	RJ45	CAN L	5	2	GROWATTCAN
			CAN H	4	1	
	IMEON ENERGY		CAN L	/	2	IMEONCAN
			CAN H	/	1	
	KEHUA SPH	/				KEHUACAN



WeCo Srl  
Viale Kennedy 113-121 Scarperia e San Piero Firenze  
[www.wecobatteries.com](http://www.wecobatteries.com)

All data subject to change without notice. Actual product color may vary. No part of this document can be copied or reproduced, electronically or mechanically, without written permission from the company.